



Consumers' pro-environmental behaviour impacts on
the choice and WTP for innovative sustainable food
packaging

A thesis submitted in fulfilment of the requirement for the Degree of
Doctor of Philosophy

School of Agricultural, Policy and Development

By

Nur Hafizah Binti Muhammad

December 2019

Acknowledgement

In the name of Allah, the Most Gracious, the Most Merciful.

First and foremost, I would like to thank my Creator for giving me a still functioning and mind in order to live life and learn, and particularly to work on my research project, hereby completing my PhD's studies.

I must give my high, respectful gratitude to my supervisor, Associate Professor Dr Giuseppe Nocella, who has patiently in guiding me through my PhD journey here in Reading. He continually and convincingly conveyed the spirit of adventure in regard of research and excitement in regard to teach and supervise me. Without his guidance and persistent help, this thesis would not have been possible. I have learned a lot throughout these years, with many challenging yet valuable experiences to finish this journey.

I would to express my eternal appreciation towards my parents and family who have always been there for me no matter where I am in the world, for all unconditional supports, advices and patience. Thank you for being so understanding, supportive and healthy when I am away from the family. And more, special thanks to my dear friends and colleagues, especially fellow Malaysian postgraduate students, housemates and officemates, it has been great to know all of you during my time in University of Reading. Remembered but not forgotten, my colleagues in Universiti Malaysia Kelantan (UMK), Faculty of Hospitality, Tourism and Wellness, for their encouragement and support to me for completing my study.

Finally, I would like to thank my examiners, Dr Fabio Bartolini and Dr Daniele Asioli and the chairman Professor Srinivasan for their encouragement and help during my viva. In addition, a thank you to Dr Ricardo Scarpa for permission to adopt and adapt the syntax of mixed logit estimation in WTP space to include in Chapter five of my thesis. I thank Ministry of Education, Malaysia and my employer, UMK for the financial supports and make ease of my study here.

Abstract

The growing awareness of the environmental damage associated with food product packaging waste has led the public to a keen interest in the development of sustainable packaging. The development of sustainable packaging capable of reducing packaging waste may contribute to slowing down environmental damage caused by current unsustainable packaging material. However, previous research in consumer behaviour shows that not all sustainable attributes of food packaging would encourage consumers' decision-making towards more sustainable choices. This pattern might be explained by the lack of understanding on behalf of the food industry and policymakers of what sustainable packaging attributes consumers prefer and of what motivations can influence consumers' preferences and willingness to pay (WTP) towards innovative sustainable packaging. To fill such a gap, this study aims to explore how consumers' pro-environmental behaviour affect their purchasing decisions in the context of innovative sustainable food packaging in the UK. A psychology environmental theory (value-belief-norm) was combined with stated choice methods to assess how consumers' values and beliefs of environmental concern and personal norms influence WTP for new bioplastic food packaging obtained from agricultural waste and tree cellulose. To assess consumer preferences and WTP for this innovative eco-friendly packaging material stated choice experiment on innovative milk packaging and contingent valuation on innovative bioplastic material packaging were applied to their basket of food products. Data were collected online and was administered to a sample of 600 UK respondents. Structural equation modelling was performed to confirm the goodness of fit of the proposed conceptual framework, while mixed logit model and Tobit model were used to estimate WTP for eco-friendly packaging. Results indicate that environmental values and beliefs together with socio-demographic characteristics of respondents influenced consumers' pro-environmental purchasing behaviour subjectively. Purchasing decisions were influenced positively by female, young and married respondents with knowledge of bioplastic packaging material. On the average participants were WTP £2.72 extra for bioplastic packaging in food products. Respondents also showed to prefer sustainable packaging made from certified agricultural waste because of its recyclable and biodegradable characteristics. The study also found empirical evidence that some consumers tend to use attribute cut-offs in decision-making and thus to support the hypothesis that ignoring cut-off attributes in the estimation model may generate biased estimates.

Keywords: Sustainable packaging, Bioplastic, Value-Belie-Norm theory, Willingness-to-pay, Packaging waste, Attribute cut-offs.

Declaration of original authorship

Declaration: I confirm that this is my own work and the use of all material from other sources has been properly and fully acknowledged.

Nur Hafizah Muhammad

Table of contents

Chapter 1

1.1 Food packaging and waste problems	1
1.2 Public and private sectors' responsibility.....	4
1.3 Research gaps.....	6
1.4 Aim and objectives.....	8
1.5 Structure of the thesis.....	9

Chapter 2

2.1 Introduction.....	11
2.2 Food packaging and its application.....	11
2.3 Food packaging waste.....	14
2.4 Law and legislation of food packaging waste in the UK.....	16
2.5 Issues and insights for the development of sustainable food packaging.....	20
2.5.1 The environmental dimension of sustainable packaging.....	22
2.5.2 The social dimension of sustainable packaging.....	24
2.5.3 The economic dimension of sustainable packaging.....	26
2.6 In case of dairy milk in the UK: Consumers' preferences attributes of milk packaging.....	27
2.7 Consumers' attitudes and purchasing behaviour towards sustainable packaging	30

Chapter 3

3.1 Introduction.....	37
3.2 In-depth interviews.....	37
3.2.1 Recruitment and data collection.....	40
3.2.2 Analysis and results of the interview data.....	41
3.2.3 Identification of context-specific themes.....	42
3.2.4 Results.....	44
3.2.4.1 The marketing and economic theme.....	44
3.2.4.2 The packaging policy theme.....	45
3.2.4.3 The packaging design theme.....	47
3.2.5 Conclusions of in-depth interview.....	49
3.3 Focus groups.....	51
3.3.1 Development of the focus group protocol and guidelines.....	51
3.3.2 Sampling, recruitment procedure and preparations of the focus group.....	55
3.3.2.1 Sample size.....	55
3.3.2.2 Recruitment process and preparations of focus group.....	56
3.3.3 Data analysis.....	57
3.3.3.1 Data coding and construction of codes.....	58
3.3.3.2 Identification of sustainable packaging innovations.....	59
3.3.4 Focus group results.....	59
3.3.4.1 Comprehension of the sustainability concept	60
3.3.4.2 Perception of current food packaging.....	62
3.3.4.3 Preferences for eco-friendly packaging	64
3.3.4.4 Perceived responsibility of authorities and food producers.....	66
3.3.4.5 Eco-labelling issues and policy implications	68
3.3.4.6 Consumer preferences of the sustainable packaging attributes.....	70
3.3.5 Conclusion of focus group discussions	72

Chapter 4

4.1 Introduction.....	75
4.2 Research philosophy and adopted research strategy.....	75
4.3 Operationalisation of the pro-environmental behaviour conceptual framework.....	77
4.3.1 Measurements of values, beliefs and norms.....	80
4.3.2 Milk shopping habits and knowledge of sustainable packaging.....	86
4.3.3 Measurement of WTP of innovative sustainable packaging.....	88
4.3.3.1 The choice experiment of innovative bioplastic for milk packaging.....	88
4.3.3.2 Selection of salient attributes and relative levels.....	90
4.3.3.3 The experimental design of the innovative bioplastic packaging.....	93
4.3.3.4 The bioplastic packaging market scenario	95
4.3.3.5 Elicitation of attribute cut-offs of the compensatory model.....	98
4.3.4 Elicitation of WTP for food products marketed with eco-friendly packaging.....	100
4.4 Statistical and econometric analysis.....	103
4.4.1 Statistical modelling of VBN constructs.....	103
4.4.2 Econometric modelling of WTP elicited via the choice experiment.....	107
4.4.3 WTP econometric modelling of CV.....	111
4.5 Target population, sample size and sampling strategy.....	112
4.6 Data collection.....	114
4.7 The pilot study.....	115
4.8 Summary.....	118

Chapter 5

5.1 Introduction.....	119
5.2 Sociodemographic characteristics and shopping habits of respondents.....	119
5.3 Exploring the latent variables of VBN to predict WTP.....	123
5.4 Heterogeneity of preferences for bioplastic packaging attributes with and without the attribute cut-off violations.....	132
5.5 WTP of agricultural waste bioplastic for food packaging.....	146
5.5.1 Factor influencing WTP for agricultural waste bioplastic packaging.....	147
5.6 Conclusions	153

Chapter 6

Conclusion.....	155
Limitations of the study.....	161
References.....	163
Appendices.....	183

List of tables

Table 3.1: Initial questions of in-depth interviews.....	38
Table 3.2: Derivation of themes, codes and plausible words in codes.....	43
Table 3.3: Socio-demographic and economic characteristics of participants.....	57
Table 3.4: List of the familiar and important sustainable food product labels.....	70
Table 4.1: Summary of EGO, ALT and BIO items.....	81
Table 4.2: Summary of NEP items.....	82
Table 4.3: Summary and sources of the AC items.....	84
Table 4.4: Summary and source of the AR items.....	85
Table 4.5: Summary and sources of the PN items.....	86
Table 4.6: Association between attributes, salient options and explanations.....	90
Table 4.7: Attributes and its level of bioplastic milk packaging.....	91
Table 4.8: Profiles and blocks of the initial fractional orthogonal D-optimal design	95
Table 4.9: Payment card.....	103
Table 4.10: Quota sampling of the UK population 2015.....	114
Table 4.11: Calibration of the orthogonal D-optimal design after the pilot study.....	117
Table 5.1: Respondent composition.....	120
Table 5.2: Respondent's dairy milk shopping habits.....	122
Table 5.3: Initial measurement model (Model 1) fit indices.....	124
Table 5.4: Part of MI of regression weights in measurement model 14.....	125
Table 5.5: Final measurement model (Model 21) fit indices.....	127
Table 5.6: Structural model fit indices.....	128
Table 5.7: Hypothesis testing of the VBN-based research framework.....	130
Table 5.8: Correlation estimates between the exogenous variables.....	130
Table 5.9: Mean and reliability test of the VBN latent dimensions.....	131
Table 5.10: Frequency of self-reported cutoffs and instances cut-offs violations.....	132
Table 5.11: ML models with and without attribute cutoffs violations in WTP space	134
Table 5.12: Latent-class logit model with five classes based on the choice decision.....	144
Table 5.13: Frequency of WTP for agricultural waste bioplastic food packaging.....	146
Table 5.14: Tobit regression analysis on demographic and psychological variables on WTP of agricultural waste bioplastic food packaging.....	148

List of figures

Figure 1.1:	Packaging waste generated by EU countries in 2016.....	2
Figure 2.1:	The evolution of food packaging functions and materials.....	12
Figure 3.1:	Fifteen initial codes clustered by word similarity.....	41
Figure 3.2:	Marketing and economic.....	44
Figure 3.3:	Packaging policy.....	46
Figure 3.4:	Packaging design.....	47
Figure 3.5:	Examples of focus group cards.....	54
Figure 3.6:	Parent and child themes emerging from focus group discussions..	60
Figure 3.7:	Hypothetical milk packaging by age groups.....	71
Figure 4.1:	Conceptual framework of the study.....	79
Figure 4.2:	Information of alternative sources of bioplastic.....	87
Figure 4.3:	Information on bioplastic disposal options.....	88
Figure 4.4:	An example of a choice set.....	97
Figure 4.5:	Reasons to refuse to buy food product marketed with bioplastic from agricultural waste.....	102
Figure 4.6:	A general structural equation model defined into measurement and structural model.....	104
Figure 4.7:	Conceptual model with the hypothesis.....	106
Figure 5.1:	Initial measurement model (Model 1).....	124
Figure 5.2:	Final measurement model (Model 21).....	126
Figure 5.3:	Final structural model (Model 2).....	128
Figure 5.4:	Proposed research framework.....	130
Figure 5.5:	WTP differences with Model 1 and Model 2.....	138
Figure 5.6:	WTP differences between age and income groups of tree cellulose bioplastic.....	140
Figure 5.7:	WTP differences between milk type and procurement groups of tree cellulose bioplastic.....	141
Figure 5.8:	WTP recyclable option of bioplastic among different milk packaging disposal habit groups.....	143
Figure 5.9:	Differences of with and without attributes cut-offs of CL models....	145
Figure 5.10:	Frequency on protest and non-protest of zero WTP for agricultural waste bioplastic food packaging.....	146
Figure 5.11:	Kernel density estimation of the WTP* (latent y^*) of significant sociodemographic factors.....	150
Figure 5.12:	Kernel density estimation of the WTP* (latent y^*) of significant VBN factors.....	153

List of appendices

Appendix 1: Ethical clearance for in-depth interview with experts.....	183
Appendix 2: In-depth interview research protocol.....	184
Appendix 3: Interview respondent consent form.....	188
Appendix 4: Example of interview transcription.....	190
Appendix 5: Ethical clearance for focus group discussion.....	191
Appendix 6: Focus group advertisement poster.....	192
Appendix 7: Focus group research protocol.....	193
Appendix 8: Focus group cards.....	202
Appendix 9: Focus group respondent consent form.....	206
Appendix 10: Example of focus group transcription.....	209
Appendix 11: Ethical clearance for survey.....	210
Appendix 12: Questionnaire of choice experiment Block 1 and 2.....	211
Appendix 13: QUALTRICS agreement.....	231
Appendix 14: Matrix coding results of focus group.....	232
Appendix 15: NGENE syntax for choice experiment before and after pilot study	234
Appendix 16: Initial regression weight estimation Measurement Model 1.....	235
Appendix 17: Final regression weight estimation Measurement Model 21.....	237
Appendix 18: Final regression weight estimation Structural Model 2.....	238
Appendix 19: Post Hoc test for two-way ANOVA for tree cellulose bioplastic.....	239
Appendix 20: Differences between National Statistic and sample demographic profiles.....	241
Appendix 21: Independent t-test between WTP (Model 2) attributes and dairy milk shopping habits.....	242

Abbreviation

Akaike's information criterion (AIC)

Altruistic (ALT)

Ascription of responsibility (AR)

Awareness of consequences (AC)

Bayesian information criterion (BIC)

Biospheric (BIO)

Choice experiment (CE)

Comparative fit index (CFI)

Contingent valuation (CV)

Egoistic (EGO)

Food and Drink Federation (FDF)

Goodness of fit (GFI)

Independent and identically distributed random variable (IID)

Latent class logit (LC)

Mixed logit (ML)

Modification indices (MI)

New Environmental Paradigm (NEP)

On-pack recycling label (OPRL)

Packaging Recovery Notes (PRN)

Personal norms (PN)

Producer Responsibility Obligations Packaging Waste (PROPW)

Root mean square error of approximation (RMSEA)

Structural equation modelling (SEM)

Tucker-Lewis index (TLI)

Value belief norm (VBN)

Waste and Resources Action Programme (WRAP)

Willingness to pay (WTP)

CHAPTER 1

INTRODUCTION

1.1 Food packaging and waste problems

Food and drink packaging deliver numerous benefits to food producers, retailers and consumers in relation to product containment, protection, transportation efficiency and communication. It is a complex and fundamental process involving food culture¹ and commercialisation for both food producers and consumers and has evolved from a food preservation device to a branding and marketing device. Food and drink packaging ensure convenience and product performance quality in the food industry. For example, the production of a simple tea bag involves the preparation of layers of packages, starting with transferring loose tea into an individual bag, then wrapping it into a single sachet, placing a bundle of sachets into a carton and finally wrapping the plastic coating around the tea carton. Hence, the packaging no longer merely contains the food, but it also enables convenient consumption and transportation, commercial tools, an extension of shelf-life and secure food storage (Jimenez-Guerrero, Gazquez-Abad & Ceballos-Santamaria, 2015). This illustrates that packaging is a fundamental element of food and drink products, without which their commercialisation and consumption would be almost impossible.

Despite the importance of food and drink packaging, it is widely accepted that food supply chains impact negatively on global environmental problems due to the production and disposal of food packaging materials². It is estimated that between 20% and 30% of global warming is generated from food and drink systems where the impact of food packaging constitutes approximately 10% of that amount (Silvenius et al., 2014). Though packaging exists to protect and deliver food and drink; it has created an accumulation of solid waste that now pollutes every corner of the world. Approximately 12.7 million tonnes of packaging waste, such as plastic, was dumped into the ocean in 2010 (Berto et al., 2017). Also, a study showed that over 252 million tonnes of solid waste, including food packaging waste, was produced by the European Union (EU) countries alone in 2010 (Eurostat, 2012).

¹ Food culture refers to the practices, attitudes and beliefs surrounding the production, distribution and consumption of food.

² Impact on global environmental problems through activities related to the production, distribution and consumption of food and drink activities.

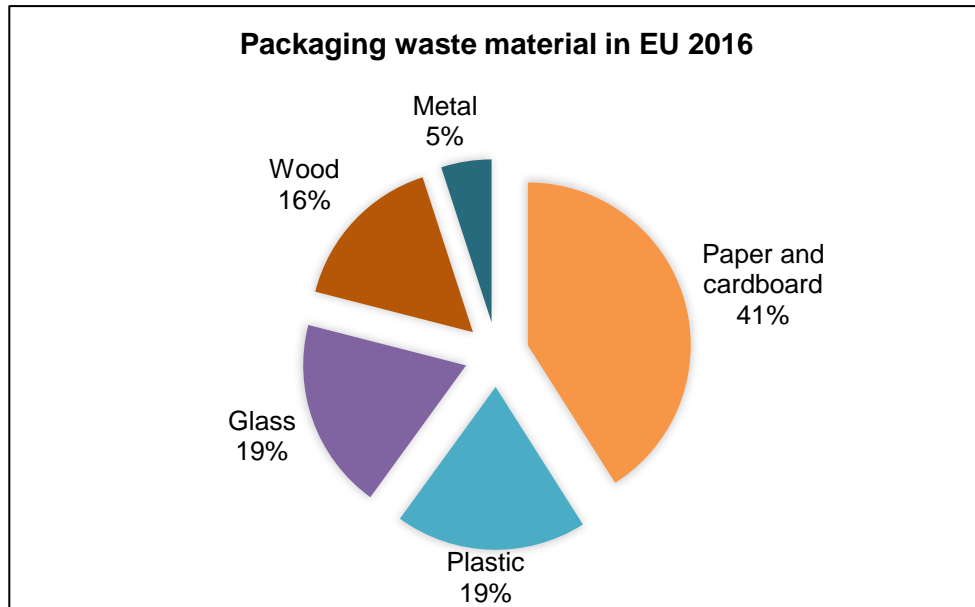

Figure 1.1: Packaging waste generated by EU countries in 2016 (Eurostat, 2016)

Figure 1.1 shows that in 2016, in the EU, paper and cardboard (41%), plastic (19%), glass (19%), wood (16%) and metal (5%) were the most common types of packaging material contained in packaging waste accumulation (Eurostat, 2016). According to Eurostat (2016), paper and cardboard were unexpectedly the main packaging waste over the previous ten years and, in 2016, they had contributed nearly 35.4 million tonnes to the total packaging waste. Even though this type of packaging was made from renewable resources, when it was contaminated or contained plastic layers, it could not be recycled and ended up in waste disposal plants (Nerin, 2008). Plastic and glass reached a total of 16.3 million tonnes of waste and were the second most significant packaging material found in the EU countries' waste. Plastic plays an important role in protecting goods and prolongs their shelf-life more than other packaging material. However, it is challenging to decompose or dispose of plastic due to the strong physical-chemical structure³ which could take years to degrade (Berto et al., 2017), and eventually, it pollutes the environment, especially when it is disposed of irresponsibly by consumers (Castellani, Sala & Mirabella, 2015).

In contrast, Figure 1.1 shown that only a few percentages of glass, wood and metal found in the packaging waste. Eurostat data found that glass, wood and metal packaging waste has decreased during the last several years due to the reduced amount of this material in the food and drink industry. This is because glass has

³ The degradation of fossil fuel plastic in the landfills depends on ultraviolet light exposure, oxygen and temperature.

generally been used to pack liquid products, and its susceptibility to breakage from internal pressure is costly to handle (Marsh & Bugusu, 2007). Wood is usually used as pallets to transport products because it helps retailers to carry a pile of product at a time (Dixon-Hardy & Curran, 2009), particularly not for use in food packaging. Similarly, metal such as tin, aluminium or steel is usually related to can products of the food industry (Piergiovanni & Limbo, 2015) which is unpractical to use as fresh food packaging.

There are two major causes of the accumulation of food packaging waste, namely the food industry's lack of consideration of the life cycle of their packaging, and the 'throwaway culture' of consumers. The food industry mainly uses packaging with multiple layers, long lasting materials and a mix of different packaging ingredients to pack food or drink products, and this is due to the versatility, durability and content security this material provides. However, this material has caused further climate problems (Andrady & Neal, 2009; Thompson et al., 2009) as some of these packaging materials are toxic, never degrade and can cause health problems (Hopewell, Dvorak & Kosior, 2009).

Furthermore, public concern has been rising because of the increase in the volume of packaging waste every year. According to Magnier & Schoormans, (2015) a person produces an average of 160 kg of packaging waste annually, which means that packaging is an important issue when considering ecological inefficiency. Not only has the volume of packaging waste increased, but there are signs that irresponsible behaviour towards the disposal of household waste contributes to the waste problem even more, in the form of solid waste being deposited on outside the home irresponsibly. The ignorance of some consumers is illustrated in that they throw their packaging waste on the streets, even though rubbish bins are available nearby (Guillard & Roux, 2014). For example, packaging such as sandwich packages and candy wrappers can clearly be seen in the streets in residential areas in the UK, and this waste eventually accumulates in the ocean.

In the light of the environmental issues highlighted above, sustainable packaging (also known as green packaging or eco-packaging) is an opportunity for the food industry and the society to reduce packaging waste pollution globally (Magnier & Schoormans, 2015). Several initiatives have been implemented by the food industry to market sustainable food packaging while maintaining its core functions. These initiatives include the development of new material, new sustainable resources, improving sustainable characteristics and upgrading existing packaging materials to be

environmentally friendly (Berto et al., 2017; Svanes et al., 2010). However, the development of innovative sustainable packaging depends both on how the public and private institutions share the responsibility of this important issue and whether the market, in particular consumers, is willing to accept eco-friendly ways of delivering food and drink products.

1.2 Public and private sectors' responsibility

The rise of public and private concern for the food packaging waste crisis has been pushing politicians and stakeholders to formulate and implement strategies which can help society to reduce the amount of packaging waste. In the UK, public authorities have implemented several packaging waste management system policies, particularly for food producers and retailers as they are directly connected to the generation and distribution of food packaging waste. The introduction of new legislation has tried to combat the environmental issues caused by commercial consumer goods packaging. For example, the landfill tax and the Extended Producer Responsibility Regulations, which came into force in 1997 and 2014 respectively, act as an attempt to encourage manufacturers of consumer goods to implement sustainable waste management. These regulations ensure that businesses accept responsibility for recovering and recycling the packaging waste of consumer goods and emphasise the shared responsibility of all the packaging waste producers in the product supply chain (Environmental Agency, 2014; Fernie & Hart, 2001).

Largely driven by the Packaging and Packaging Waste European Directive (94/62/EC), non-profit organisations such as the Waste and Resources Action Programme (WRAP) and public authorities are practically undertaking major investment to support UK food producers or retailers to create innovative food packaging that is harmless to consumers and the environment (Lindh et al., 2016; Matsueda & Nagase, 2012; WRAP, 2013a). For example, the Courtauld Commitment, a voluntary agreement funded by the UK government, aims to improve resource efficiency and to reduce waste in the UK by giving direction and assisting food producers and retailers in designing a more sustainable packaging, a type of packaging which sustains environmental health without affecting its primary purpose. This agreement has successfully identified several novel solutions and technologies to reduce household solid waste in the UK, such as major reductions in the Easter egg packaging of Cadbury and Mars products and use of more recycled content in the packaging of drink products (WRAP, 2013b).

National and EU legislation and voluntary agreements put in place to the correct market failure caused by unsustainable packaging and mismanagement of packaging waste are pushing food producers and retailers to become more focused on the re-measuring⁴ of their product evaluation and performance in the market (Molina-Besch, Wikstrom & Williams, 2018). Furthermore, consumer pressure on the food packaging waste problem, particularly plastic that piles up in the trash cans and landfills around the world, has also contributed to product evaluation (Williams & Wikstrom, 2011). At the same time, media coverage on the issue of packaging waste is dominating discussions of environmental issues by international networks and acts as a hint to food producers to act upon this issue even more (Sheffield, 2016). For example, news on the extra disposal costs that local authorities pay to clear up cities and piles of solid waste in the ocean raises the awareness of the public around the world. Therefore, food producers are challenged to re-design and innovate food packaging, which helps them to improve their business performance and simultaneously upgrade the sustainability image of their products.

Sustainability encompasses strategies and practices that aim to meet the needs of stakeholders today while seeking to protect, support and enhance the human and natural resources that will be needed in the future (Jerzyk, 2016). This notion of sustainability has led to the present situation where sustainability is no longer just 'nice to have' or exclusively part of Corporate Social Responsibility (CSR)⁵ but is seen as a business necessity to attract consumers and protect market share. This refers not only to the sustainability of the product content, but also to the packaging, and designers should emphasise the concept of sustainability for the packages used too (Gronman et al., 2013). From a producer's perspective, packaging functions as a 'silent salesman' by attracting consumer's attention to products (Creusen & Schoormans, 2005). Therefore, highlighting a specific characteristic of the sustainability of the packaging has a significant influence on consumer attitudes and purchasing decisions at the market level (Westerman et al., 2013). All in all, almost every food producer in the UK attempts to insert the sustainability element of the products to stay in the market competition of consumer goods.

Many food producers and retailers are moving towards goals such as those mentioned above, where current trends in sustainable packaging are centred on environmental safety, cost-effectiveness, and user-friendliness, whilst maintaining the primary

⁴ Re-measuring and evaluating the product cost, food shelf-life and safety, together with user-friendliness and environmental sustainability to improve more eco-friendly product.

⁵ CSR is a situation where firm goes beyond compliance and engages in some social good, beyond the interest of the firm or required by law (McWilliams, Siegel & Wright, 2006).

purpose of protecting the product. The challenge in sustainable package design is to find a good balance between product and the packaging purposes. Being green is not an excuse for poor design and high cost such as eco-friendly packaging is presumably more expensive than conventional packaging and has a weak physical appearance (Plimmer, 2013). Strategy for ensuring the sustainability of product-package combination design is of foremost importance to maintain product quality because consumers ultimately choose products to consume the food content, not the packaging (Gronman et al., 2013). Yet, another foremost important aspect of any innovation in sustainable packaging is the acceptance by the market of the product (Svanes et al., 2010). Sustainability can be an effective consumer marketing tool, capitalising on the appeal to consumers of doing good for the environment by purchasing the product. Therefore, packaging whose sustainability characteristics are acknowledged by consumers will be successful in the market (Lindh et al., 2016).

1.3 Research gaps

Environmental-awareness is currently a topic of global interest, thanks to media interest and public campaigns run by local and international authorities. As a result, many consumers are now familiar with the requirement of sustainable development, and this is evidenced by many international censuses which show that consumers are paying more attention to this issue when buying goods (Nielsen, 2014). These information tools⁶ have generated environmental knowledge for the public, leading to behavioural changes such as being more conscious when shopping and discarding packaging waste appropriately. Moreover, consumers, now more than ever, are becoming aware of the importance and benefits of clean air and renewable energy as they experience the impact of excessive waste, particularly food packaging waste (Nordin & Selke, 2010).

While it is widely accepted that packaging is a very important element of the food product in that it offers opportunities for gaining greater market shares and increasing consumer loyalty, the social aspect of sustainable food packaging is still an important area of investigation within the fields of food economics and food marketing. Currently, the research interest is shifting to elements of sustainable packaging that influence consumers' reactions with regards to this environmental issue (e.g. Koenig-Lewis et al., 2014; Lindh, Olsson & Williams, 2016; Magnier & Schoormans, 2015). Previous studies have focused on the acceptability of the sustainable packaging concept in

⁶ Information obtained from the news and campaigns on accumulation of packaging waste and need to protect the environment.

general; however, few studies have investigated the attributes of sustainable packaging which is approved by consumers. This indicates that more specific studies on packaging attributes are needed to fill the gap of the literature.

Studies in food consumption behaviour show that consumers are showing concern about sustainability issues and largely have positive reactions towards sustainability products (Tobler, Visschers & Siegrist, 2011). Even though they are aware of current problems caused by packaging and try to change their behaviours to live a more sustainable lifestyle, it has been found that consumers essentially give priority to their needs such as convenience and affordability of goods. Only after considering those needs, then they do consider their environmental values and beliefs to protect the environment (Hoek et al., 2017). Personal necessities or fondness such as comfort, availability of the environmental product alternatives, lifestyles and socio-economic conditions may perhaps significantly be the drawback factors of sustainable choices among consumers (van Birgelen, Semeijn & Keicher, 2009). Thus, the following research question will be explored: How do consumers' personal preferences, experience and socio-economic profile influence their attitudes and values towards the physical acceptance of sustainable packaging?

It appears that so far, the consumers' acceptance and preferences of the sustainable attributes of food packaging have received less attention than that given to sustainable food products such as organic or local food. The success of a sustainable package is highly dependent on consumers' understanding and acceptance of the innovative attributes of packaging. If consumers feel that a product's packaging will cause them to inconvenience such as it is difficult to dispose of or it creates extra waste in the house, then that sustainable packaging will become an unacceptable idea to them (Magnier & Schoormans, 2015). Lack of information about consumers' preferences of sustainability attributes suggests that empirical studies must be conducted to inform policymakers, food producers and food retailers the part of sustainable packaging attributes require more attention. They (policymaker, food producers and retailers) might have different visions of innovative sustainable packaging, but the ideal sustainable container cannot be developed without taking into account the voice of consumers. In order to fill this gap, the following research questions will be answered: What is the most preferred sustainable attributes for food and drink products currently? How do consumers perceive sustainable packaging innovation so far and any innovation that the food industry is focusing on?

The sustainable attributes of food packaging continue to be debated among researchers, policymakers and food producers who seek to understand how to satisfy consumers' environmental values and their purchasing intentions. They are concerned about packaging waste issues but seem to be unwilling to take actions in purchasing decisions, particularly due to the product price or personal preferences of products' attributes (van Birgelen, Semeijn & Keicher, 2009). For example, evidence shows that consumers perceived that sustainable products are likely to be expensive and high quality (Magnier, Schoormans & Mugge, 2016) and thus unaffordable for some of them. Moreover, not all sustainable attributes can lead to a positive judgment of the market. For example, edible packaging in the US experienced a great challenge to market due to the fact that consumers felt it to be unhygienic (Cheek & Wansink, 2017). Meanwhile, in Europe, young consumers were more open to biodegradable packaging compared to the older generation (Giancristofaro & Bordignon, 2016). It seems that consumers are aware of the concept of sustainability that producers include in the packaging of their products, but they are not able to support it entirely due to the uncertainty of the sustainable attributes and dissimilar own preferences as a consumer. Through the inconsistency of consumers' pro-environmental behaviour regarding the acceptance of sustainable packaging, the following research questions are addressed: What are the indispensable sustainable attributes of new food packaging that can improve consumers' satisfaction and at the same time match their concern to the environment? Do socio-economic profiles, past experience and psychological elements influence consumers' pro-environmental behaviour in the context of purchasing if new sustainable packaging marketed?

1.4 Aim and objectives

In the light of research gaps and subsequent research questions stated above, this study aims to explore how consumers' pro-environmental behaviour affects their purchasing decisions in the context of sustainable food packaging in the UK. Before any investigation into consumers' evaluation of packaging attributes, there is a need to clarify the innovation of sustainable packaging made by the relevant industries through the years since the early 2000s. This information will enable development of valid and reliable sustainable attributes in food packaging from which to measure consumer's perception and acceptability. Moreover, the UK food industry might focus on different sustainable attributes to other countries. So, with this information from retailers and producers, the packaging performance and crucial sustainable attributes of food packaging will be examined. Hence, this gives rise to the objectives of the study:

- To critically assess previous literature which has investigated consumers' preferences and pro-environmental behaviour in the context of sustainable packaging.
- To investigate the main innovations of sustainable food packaging by food producers, retailers and industry experts in the UK.
- To understand how consumers' pro-environmental behaviour towards sustainable food packaging is influenced by their values, beliefs and social norms.
- To evaluate consumers' preferences and willingness to pay for the sustainable attributes of innovative sustainable packaging.
- To identify the compensatory attributes of sustainable packaging about which consumers are willing to compromise when making their choices.
- To analyse the effects of consumers' environmental values and beliefs, socio-economic status and attitudes on choice behaviour when choosing sustainable packaging alternatives.

1.5 Structure of the thesis

The remainder of this PhD thesis is structured as follows. Chapter 2 examines the current environmental problems generated by food packaging waste, reviews the theoretical and technical aspects of sustainable packaging and discusses previous studies related to consumers' reactions to the sustainability challenges of the food industry. The latter studies focus on how psychological aspects and values of individuals influence their pro-environmental behaviour. This sets the context for this study.

Chapter 3 presents the qualitative research methods of this study and is divided into two parts. Each part presents the methods and results of the two qualitative techniques used in this study: 1) in-depth interviews with stakeholders and 2) focus groups with consumers. The chapter highlights important aspects of sustainable innovation in food packaging by the major industrial actors such as the non-profit organisation, WRAP and major retailers in the UK. Meanwhile, this chapter also provides insights for consumers' preferences of sustainable packaging used in the quantitative study.

Chapter 4 presents this study's quantitative research method, where a conceptual framework was developed to explore how values, beliefs and social norms influence consumers' stated preferences of innovative sustainable packaging. This chapter presents the methodological tools used (questionnaire, sampling, statistical and

econometric techniques) to estimate the impact of socio-economic and psychographic determinants on consumers' preferences and willingness to pay of novel attributes of sustainable packaging.

Chapter 5 presents and discusses the results of the quantitative findings obtained from the estimates of the following three models: 1) a structural equation model to validate the environmental Value-Belief-Norm conceptual framework used in this study; 2) a mixed logit model in WTP-space to estimate willingness to pay for innovative sustainable packaging attributes incorporating compensatory and non-compensatory decision-making; 3) a Tobit model to estimate willingness to pay for an increase in total expenditure for buying food products marketed with sustainable packaging.

Finally, Chapter 6 discusses the managerial and theoretical implications of this research, explores the limitations of the current study and suggests directions for further studies.

CHAPTER 2

LITERATURE REVIEW

2.1 Introduction

This chapter describes the performance of food packaging and its importance in the food and drink industry as well as the potential benefits of implementation of sustainable aspects into the packaging. The chapter also provides the essential explanations of the sustainability aspects of food packaging and the legislation detailing stakeholders' responsibility towards the food packaging they produce or use to market their products. The chapter continues with the three dimensions of sustainable packaging to be considered in food and drink packaging design. Lastly, consumer attitudes and purchasing behaviour with respect to sustainable packaging is discussed, focusing on the consumer's understanding and perceptions as reported in the literature. Finally, the chapter includes a discussion of the issues that appear with the implementation of sustainable packaging in the market.

2.2 Food packaging and its application

Packaging design is the result of a process that combines food science, processing and preservation technology. This process is very important because, as well as minimising costs along supply chains, packaging must allow food to be transported, distributed, stored and marketed in a safe and appealing way for consumers (Shin & Selke, 2014). Food packaging has been evolving continuously in humankind's history, and now more than ever packaging technology is used to enable food to be transported uncontaminated over long distances to provide consumers with high-quality food and drink products (Marsh & Bugusu, 2007). Figure 2.1 shows how packaging has evolved over time in terms of functionality and materials.

As regards functionality, Figure 2.1 shows that going from fundamental to tertiary, nowadays the use of packaging in the food industry transcends its basic purpose of simply containing and protecting a product. Consumers demand not only convenient, but also high-quality food products where packaging is a part of it (Shin & Selke, 2014). Also, packaging has become a tool for marketing and branding without the attendance of the manufacturers at the point-of-purchase. Packaging must be enabled consumers to identify the product through a distinctive design or brand and be recognisable at first glance on the shelves of supermarkets. Therefore, the purpose of packaging has

changed from merely protecting the food to enhancing opportunities to gain more consumer attention when evaluating the product's characteristics. For instance, the graphic design of the packaging portrays the idea of an 'authenticity' of the product, such as the Coke bottle, because the consumer can differentiate this product from other soft drink bottles (Barnard, 2005).

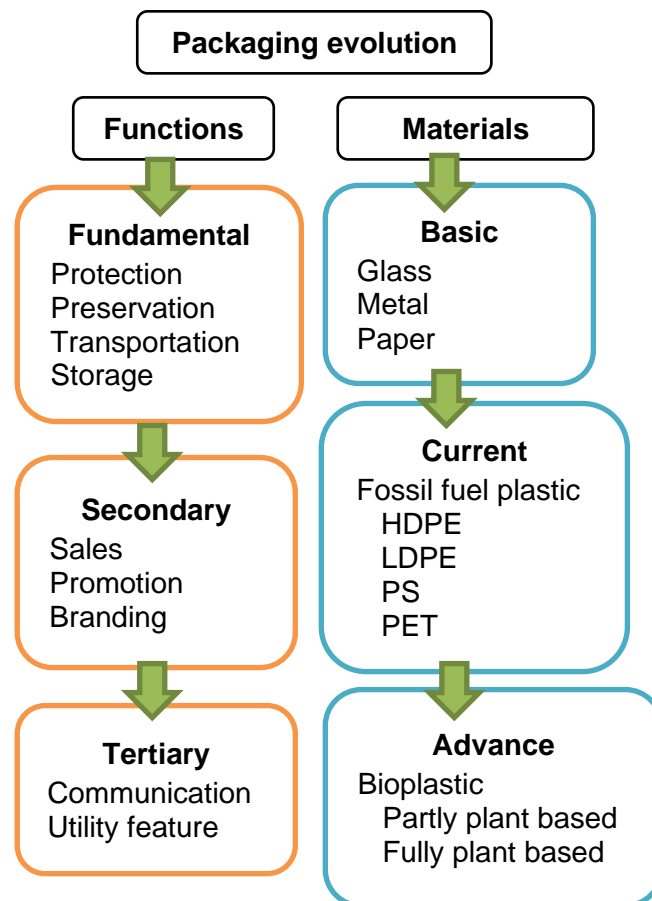

Figure 2.1: The evolution of food packaging functions and materials

Despite the fact that healthy, safe and hygienic packaging is always a priority to stakeholders in order to increase consumers' trust and loyalty, they have also to take into account consumers' demand for packaging which has more functions, i.e. tertiary (Figure 2.1). The industry has responded to consumers' needs and changing lifestyles with the development of multipurpose design packaging which embodies attributes such as individual packs for people living-alone or being very busy (Shin & Selke, 2014). Moreover, food packaging acts as a communication instrument for any information regarding the product. Besides mandatory nutritional information and traceability (e.g. barcode) of the product, a recent trend indicates that the packaging label can be used to tell a story or display an attractive image of the product that can

persuade consumers at the point-of-purchase. According to Barnes (2017), this trend has begun to develop a more emotional relationship between the product and the consumer, bringing loyalty and sense of belongings towards the specific brand of the food product.

With regard to material, packaging also plays a significant role in the image and health of the product. The right selection of packaging material is important to encourage consumer attention to the products. Traditionally and still in use, metal and glass have an extremely long history in food packaging. Glass claimed to be the first material used as food container centuries ago. Besides being odourless and chemically able to withstand a high temperature of food processing (Marsh & Bugusu, 2007), glass gives an impression of exclusivity to a food product. For example, extra virgin olive oil packed in glass bottles looks expensive and authentic on the supermarket shelves when compared to other packaging materials. Meanwhile, metal was introduced as food packaging due to its versatility of excellent physical protection and barrier properties. Metals such as steel, aluminium and tin are commonly used in the production of food and drink cans. Even though it is physically unattractive and lacks transparency, it provides an outstanding barrier to odour, air, and moisture from outside and guarantees a long shelf-life of the food products (Shin & Selke, 2014). Paper and paperboard packaging have also been in use for many years and are materials that are improved continuously. Paper packaging is commonly produced from fibres from plant and agricultural by-products such as straw (wheat, rye, barley and rice), sugar cane bagasse, flax and corn husks. Unlike other types of packaging materials, the use of paper in food packaging is very limited due both to the poor barrier properties and its incapability to protect food for long periods. Furthermore, stakeholders must invest relatively excessive costs to treat and process paper to make it strong enough to hold food products (Kopacic et al., 2018; Shin & Selke, 2014).

On the other hand, the most versatile packaging material, and one that has been used in almost all food products, is fossil fuel plastic. The use of plastic has increased more rapidly than other packaging materials due to its low costs and functional advantages, such as its unlimited size and shape, heat resistance and optical transparency (Lopez-Rubio et al., 2004; Shin & Selke, 2014). Several plastic derivatives have been developed to increase its application in food packaging, such as high-density polyethylene, low-density polyethylene, polyethylene terephthalate, and polystyrene. Until now, there have been more than 30 types of plastic used in food packaging around the world (Lau & Wong, 2000). However, the alarming observations of plastic waste being spread in oceans, rivers and lakes due to both land-based and sea-based

activities had caused the food industry to seek new or alternative material for food packaging. Even though some fossil fuel plastics are designed to be recycled, recycling of plastic is still at a low level compared to the total of plastic production annually (Dahlbo et al., 2018; Othman, 2014).

Figure 2.1, above, illustrates that, recently, bio-based plastic has become one of the most interesting advances in technology that the food industry is focused on. Bio-based plastic is a packaging material that is at least partly-derived from biomass, which is made from renewable sources and natural substances without polluting the environment. The bio-based polymer, also known as bioplastic, can be recyclable, biodegradable and compostable (European Bioplastics, 2017). Even though the development of this packaging is still in a stage of infancy, it is believed to have positive effects on the environment because it reduces the dependency of the food industry on fossil fuel plastic, increases the likelihood of more organic waste recycling and reduces contamination from conventional plastic (CEBR, 2015). Recently, current consumers' preferences for environmentally sustainable materials have driven market demand for this bioplastic material. A great deal of research is investigating strengthening the inner structure of bioplastic to improve the flexibility of this plant material (Othman, 2014). However, the UK bioplastic manufacturing industry is still developing, and not all components of the industry have been fully established (CEBR, 2015). In addition, the legislative framework of this type of material requires immediate attention.

Overall, basic functions and packaging materials have advanced beyond just protecting a product's security. Current packaging provides consumers with more options, comfort and hassle-free when making their daily food choices. Moreover, packaging exposes consumers to pre-experience before purchases and it can boost sales for producers to help them stay in the competitive environment. Packaging has become part of our culture and is an essential component of food products, without which, in many cases, consumption would be almost impossible.

2.3 Food packaging waste

The production, consumption and disposal of packaging has led to significant social and environmental problems because of excessive waste. According to the Waste Framework EC Directive 75/442/EEC, food packaging waste means any packaging or packaging material that has been used to cover food or drink items (served as the intended purpose) which are disposed of or are intended to be disposed of or are

required to be disposed of (Silva et al., 2013). The rise of the packaging waste crisis has been highly debated among policymakers, researchers, businesses and society in general where greenhouse effects, ocean acidification and global warming are the main points of concern (Mores et al., 2018).

These negative environmental effects have been determined by the fact that the impact of food packaging material has often been overlooked by food producers and retailers. Particularly, in the foodservice sector, about 34% of 1.3 million tonnes of packaging used in the UK is disposed of in landfills due to it being unrecyclable (Hollins, 2013). From an economic point of view, packaging materials like fossil fuel plastic dominate the choices of the food industry because of its lower prices and greater flexibility than other packaging materials, even though stakeholders know that it is not possible to recover or re-process this plastic into a new product (Peelman et al., 2014). Therefore, plastic makes up the largest amount of food packaging disposed of by households, especially in urban communities. As a result, food packaging disposal not only increases the quantity of waste in landfill and incineration centres, but also puts enormous pressure on budgets and waste management infrastructures tasked with decomposing it. Improper waste management can also create air pollution, and increased incineration processes can produce excessive greenhouse gases, such as methane and carbon dioxide (Secondi, Principato & Laureti, 2015). Unnecessary packaging used for food and drink products, such as multiple layers in tea products and bananas packed in plastic bags, is also adding problems to waste streams because of limited landfill capacity and simultaneous pollution of the environment.

The management of food packaging waste is further complicated by the fact that it is normally contaminated by food residues (e.g. food leftover in packaging), and when incinerated, the output of this process (sewage sludge), triggers significant environmental problems related to methane emissions (stench gas) and contamination of soil and water resources (Aggelakis et al., 2005). Even when landfilling and incineration can be properly achieved to minimise environmental impacts, illegal dumping and open burning carried out by irresponsible people can produce greenhouse gases that have a negative impact on climate-health and will eventually threaten public health. Furthermore, coastal systems pollution is severely affected by the dumping of plastic waste into the ocean. For example, between 4.8 and 12.7 million tonnes of plastic waste generated in 192 coastal countries entered the ocean in 2010 as the results from the local activities and actions of irresponsible citizens (Jambeck et al., 2015).

Littering behaviour of irresponsible person also impacts negatively on the environment as 80% of sea pollution comes from land-based sources (Keizer, 2008; Nellemann & Corcoran, 2006; Schultz et al., 2013). This pollution is caused by mostly from food products such as food wrappings, beverage bottles and convenience items, such as plastic packaging and cutlery (Beeharry et al., 2017). The removal and disposal of litter is not only becoming increasingly expensive but could put immense pressure on budgets and waste infrastructures of governments. In England, more than 30 million tonnes of litter are collected in the streets each year, and nearly £858 million is spent every year by local authorities for the clean-up process (Roper & Parker, 2013). Generally, this throwaway culture is a societal problem, where producers and retailers blame on consumers when the accumulation of litter on the street and only taking distances from the problem (Meikle, 2009). However, without packaging, consumers will not have anything to drop, and thus the responsibility of this environmental disaster must be shared by all economic agents working along food supply chains.

Overall, this section has reviewed the three aspects of environmental problems produced by current food packaging, namely the responsibility of producers, the behaviour of consumers, and food packaging design that contributes to excessive food packaging waste. The rise of this packaging waste crisis has triggered the attention of policymakers, and thus several policy interventions and regulations regarding packaging resources and waste management have been introduced and implemented into the society.

2.4 Law and legislation of food packaging waste in the UK

The effects of wasteful packaging in everyday practices, from littering to overconsumption, has been reported and discussed in the public sphere where the focus is on disposal management paying attention to reduction and prevention. These reports by various mass-media have raised public concern about the environmental damage caused by packaging waste and highlighted a problem of market failure. Market failure in the context of food packaging waste is determined by information failure and negative externalities. Information failure is determined both by the fact that consumers might be unaware of the negative consequences of food packaging waste or asymmetric information because producers know more than consumers and are not willing to disclose information. On the other hand, negative externalities are caused by the fact that social costs do not match private costs and thus market transactions also negatively affect the lives of people not involved in these transactions. In order to

respond to public concern, governments and businesses are adopting different measures to tackle this problem of market failure.

One such measure is a sustainable food packaging campaign launched in 2006 by the UK government, which was supported by many non-profit organisations such as WRAP and the Food and Drink Federation (FDF). In the UK, the Courtauld Commitment, introduced by WRAP, is a voluntary agreement where registered members are given advice and support in designing sustainable packaging for their products (WRAP, 2013b). This agreement aims to reduce household waste by working together with businesses to create packaging that follows the standard packaging rules and is safe for the environment. Moreover, producers or manufacturers in Europe are also encouraged to develop packaging waste management systems which must be approved by the national waste authority to comply with any recycling and recovery requirement legislated for by the country (Ferreira da Cruz et al., 2014). In non-European countries such as Canada and the USA, other initiatives have been launched by large retailers to consider sustainable packaging. For example, in the USA Walmart launched the 4Rs campaign (reduce, recycle, reuse, rethink) having the purpose both to optimize sustainable packaging and to improve the use of packaging materials, which could reduce waste, and increase recycled content and the amount of renewable materials involved in the packaging manufacturing (Magnier & Crie, 2015).

In 1994, the European Union introduced the Directive on Packaging and Packaging Waste (94/62/EC), which encourages member states to introduce national regulations concerning the management of packaging waste produced by the industry, businesses, shops, services and households (Fernie & Hart, 2001; Tencati et al., 2016). The directive focused on quantitative targets for recycling and recovering packaging waste, and it was well received by all European countries. Most European countries focused on recycling as a scheme of waste prevention and recovery. However, the UK government set the lowest recycling target, at a recovery rate of 38% in comparison to other European Member states, who established targets between 45% and 65% in 1997 (Fernie & Hart, 2001). In the UK, the Producer Responsibility Obligations Packaging Waste (PROPW) was introduced in 1997 to meet the requirement of the EU Directive. The 'recovery' term in the PROPW referred to the transformation of packaging waste into a new product, reprocessing and incineration for energy recovery (Fernie & Hart, 2001). The focal point of the PROPW is to share the responsibility of recovering packaging waste with all supply chain actors including raw material suppliers, manufacturers, producers, packers and retailers accountable

for the product that they sell on the market. The legislation guaranteed that they share the responsibility to ensure that any packaging produced is recovered and does not pollute the environment from the start until the disposal stage. Amendment of the PROPW has been made almost every year to ensure that the target recovery of packaging waste can be achieved as planned. In 2017, the UK government increased the target to 75% of total packaging waste recovery (CIWM, 2016).

Unfortunately, PROPW was criticised when some producers refused to follow the legislation and were less concerned about packaging waste recovery as they were not producing packaging. Thus, a scheme called Packaging Recovery Notes (PRN) was introduced with the scope of acting as evidence for a certain amount of recovery completed by any manufacturer. Only accredited packaging reprocessing plants (for example recycle centres) have the authority to issue PRN to every responsible actor in food supply chains generating packaging waste (Matsueda & Nagase, 2012). Packaging producers, handlers or any actors in a product supply chain are obligated to purchase PRN every year based on the type of their business and the amount of packaging they handle. The PRN implementation has successfully forced them to take into account the cost of treating the final by-product of the waste indirectly. As a result, the rate of recycling waste has increased to more than 60% recently, and the UK has risen towards the middle of the recycling rate rankings (Advisory committee on Packaging [ACP], 2008). Other European countries are also adopting other regulations. For instance, the Green Dot scheme adopted in Germany imposes a financial contribution to producers in favour of another entity collecting and reprocessing their packaging waste and recovery services. This scheme has become compulsory legislation in Germany and some European countries, while in the UK it is a PRN agreement (Okuda & Thomson, 2007) and Courtauld Commitment (WRAP, 2013b).

The policies of the EU and the UK have encouraged product manufacturers to produce packaging that reduces waste, such as reusable and recyclable packaging material. This approach was implemented to counteract the increasing annual amount of packaging waste where calls for clearer and more robust policy measures had to be put in place to involve responsible parties generating waste. As a result, the EU Waste Framework Directive 2008/98/EC focused attention towards environmental protection and resources efficiency as part of packaging waste prevention plan (Mazzanti & Zoboli, 2008). The Directive was amended for further actions to be taken in improving packaging design and production through extensive use of the product life cycle

assessment, promoting collaborative efforts along the packaging supply chains and raising the awareness of final consumers by increasing the accountability of businesses (Tencati et al., 2016).

The impetus of legislation dealing with packaging waste reduction also comes from major retailers and businesses who are trying both to re-think food packaging and to educate consumers on how to dispose of packaging waste responsibly. In response to the accumulation of food packaging waste, a range of legal actions, initiatives and policy regulations have been developed that have the objective of increasing the efficiency of waste management. Some European and non-European countries have introduced labelling systems on how to sort packaging waste in order to make their products more competitive. These information remedies educate consumers about packaging waste, increase consumers' pro-environmental attitudes with less attention towards sustainability, and positively influence their purchasing decisions (Testa et al., 2015). In the UK, manufacturers and retailers use symbols or logos, such as the Forest Stewardship Council or EU Ecolabel, which are strategically printed and displayed on the label with eye-appealing colour (Grunert, Hieke & Wills, 2014). Primarily, this approach attempts to strengthen the producer's negotiation capacity on consumers' purchasing intentions. These labels seem useful for some consumers who want to improve the quality of their life by consuming more environmentally-friendly products.

Similarly, some European countries promote the adoption of ecological labels based on the assessment of the environmental characteristics of the products, such as German Blue Angel and Nordic Swan Sweden (Tencati et al., 2016). Providing detailed information and giving transparency to the consumers is a better marketing strategy for sustainable packaging. Outside the EU, the food industry is also liaising with private organisations, such as the Sustainable Packaging Coalition in the USA and the Sustainable Packaging Alliance in Australia, to help stakeholders to achieve a mutual understanding of sustainable packaging systems. For example, the Sustainable Packaging Alliance describes the sustainable packaging concept as effective use of resources and technology, efficient manufacture practices and design and environmentally recovery design and healthy materials; and simultaneously safe to human and environment (Jerzyk, 2016).

To conclude, this section demonstrates that legislation of packaging waste has shifted the emphasis from reducing to preventing waste, from the farm to the fork. These policies require all producers and retailers to take action, voluntary or mandatory, from packaging design to the production stage of the product. These actions include re-

thinking the life cycle of the product they market, whilst paying attention to what will happen to the packaging material when it is disposed of, and what damage it will cause to the environment. This discussion also highlights that waste management and environmental sustainability policies have become strictly linked to each other. The ideas and mechanisms that frame waste regulations are not only protecting ecosystems from excessive resource extraction and limiting the impact of harmful substances on the health of the environment and human beings, but also pushing the food industry towards innovative sustainable packaging.

2.5 Issues and insights for the development of sustainable food packaging

The development of sustainable packaging development begun in the early 2000s, when non-profit organisations began encouraging retailers or stakeholders to modify household product packages towards eco-friendliness (Jerzyk, 2016). Moreover, following the implementation of those regulations as mentioned in above section, the majority of companies chose to implement environmental or sustainability policies under Social Corporate Responsibility⁷ (Roper & Parker, 2013). This is a business voluntary commitment where businesses try to balance social responsibility against profit maximisation. Thus, companies have started to develop food packaging which could reduce environmental problems from the initial stages of production, i.e. identifying packaging material and production processes that are environmentally friendly. Introducing sustainable packaging seems to be a reasonable strategy for food companies because they can address public concern about packaging waste (Magnier & Schoormans, 2015). Given that 96% of European citizens agree that initiatives should be made to limit plastic waste and extend recycling (European Commission, 2014), this strategy is a positive one.

Ideally, sustainable packaging should be developed taking into account the definition of sustainable development proposed by the Brundtland Commission (1987): 'development that meets the needs of the present without compromising the ability of future generation to meet their own needs'. This means that food companies should develop innovative sustainable packaging which balances profitability and the responsibility of businesses towards the waste problem, thus considering material

⁷ Social Corporate Responsibility (SCR) is a voluntary commitment of businesses to improve the environmental protection. There are several actionable items that businesses can put in place to make differences. They include design of packaging and products with recycling in mind, buying from sustainable suppliers, reusing materials, optimising waste management, reducing energy and water use and supporting environmentally friendly disposal practices (Roper & Parker, 2013).

which reduces environmental damage without compromising the lives of future generations (Nordin & Selke, 2010). The Brundtland report emphasises that sustainability has to be achieved by improving environmental protection, social equity and economic prosperity of all. This means that sustainable packaging can be considered successful when the waste problem is reduced, natural resources are well preserved and at the same time, people's well-being and countries' economies are positively improving. When developing sustainable packaging, the simultaneous improvement of these three areas is impossible to achieve by one company in isolation, hence manufacturers have to consider insights from consumers and other economic agents within food supply chains (Lindh et al., 2016).

The development of sustainable packaging is complicated by several issues because food products require different types of packaging. Countless arguments and suggestions on packaging material should be carefully considered to ensure efficient use of materials with the lowest environmental impact while providing sufficient protection to the food. The selection of sustainable packaging material also needs to consider providing sufficient protection to the food's content, to withstand the processing requirements and legal requirements (Marsh & Bugusu, 2007). For example, the importance of shock absorbing packaging material for fruits during transportation and handling is paramount to avoid bruising and, as a consequence, rejection of the fruit by consumers, at which point it becomes waste material (Lindh et al., 2016). This implies that sometimes extra packaging material or non-environmentally friendly material is necessary to avoid another environmental burden from wasted food products such as damaged fresh fruits.

Another issue is related to extra packaging material that is deemed unnecessary for particular food products such as fruits and vegetables. However, producers argue that this extra packaging can contribute to the reduction of food waste by prolonging the shelf life of products, which also fulfils the consumer's demand. In the UK, Advisory Committee on Packaging (2008) reported that plastic wrapping prolonged the shelf life of cucumbers from 3 to 14 days because the plastic prevents the evaporation process. Hence, this increases the likelihood of selling the product over a longer period and also of the product being consumed by consumers. These two situations illustrate the delicate trade-off between how much packaging material is needed with optimisation of resources used to avoid too much negative impact on the environment. The packaging material is necessary to maintain product quality, but at the same time, the impact on the environment should be decreased.

The starting point of food packaging design is the minimum requirement of the food item itself and followed by the consideration of the whole life cycle of the product-package combination. Creating a sustainable food package is as much art as science, trying to achieve the best overall result without falling below acceptable standards in the many aspects of the packaging roles. Ultimately, consumer acceptance plays the most significant role in package design in the food industry. The purchasing decision process can be enhanced by an appropriate design which will promote positive environmental behaviour among consumers and influence their purchasing intentions of sustainable packaging (Martinho et al., 2015). Even though packaging is a significant tool to influence consumer preferences, the primary purpose of food packaging must continue to be maintaining the safety and wholesomeness of the food. To this end, there are three sustainable design dimensions for sustainable food packaging which serve as the basis of any food technology and environmentally-friendly packaging studies. These dimensions incorporate valuable aspects of sustainability from both manufacturer and consumer perspectives and are i) environment, ii) economy and iii) social aspects. These dimensions are discussed in the following sections.

2.5.1 The environmental dimension of sustainable packaging

According to EU Directive 94/62/EC, essential environmental requirements of sustainable packaging are linked to its reusability and ability to recover back to nature. A package must be produced by limiting its negative influence on the environment throughout its whole lifecycle. There are different frameworks, models and guidelines proposed by researchers and practitioners on the environmental dimension of sustainable packaging development. These models emphasise the importance of saving resources and the responsible use of non-renewable natural resources while, at the same time, encouraging the use of renewable resources (e.g. plant-based material) to control greenhouse gas emissions and cultivating more plants to increase the oxygen level in the environment (Mores et al., 2018). Previous studies have identified two important aspects of the environmental dimension of innovative sustainable packaging: resources optimisation and recovery design.

Optimisation of packaging resources is the main element emphasised by most waste and environmental policies. The general principle of sustainable packaging that attains design efficiency is the optimisation of resources by 'doing more with less' (Gronman et al., 2013). The World Business Council for Sustainable Development in 2000 called this approach 'eco-efficiency' because it challenges food producers to create more

value with less packaging. The issue of source reduction has increasingly captured the attention of stakeholders because it simultaneously improves other aspects of food product production. For instance, the elimination of unnecessary packaging reduces the thickness of packaging and minimises the layer from primary until tertiary packaging of food products, resulting in minimisation of production costs (Envirowise, 2002; Lewis, 2008). Moreover, another essential component of source reduction is the reduction of unnecessary void space of packaging by containing the appropriate quantity of food or drink inside.

The concept of recovery design refers to another efficiency consumption of packaging resources, which is termed 'Cradle to Cradle'. This term was put forward by Braungart, McDonough and Bollinger (2007) to replace the term 'Cradle to Grave' in relation to the packaging life cycle. The concept is based on the notion that, if humans truly want to respect nature, they need to follow the cradle-to-cradle of nutrients and ecosystem cycles. In other words, to design packaging with the idea that waste does not exist. Sustainable packaging should be giving benefits through its entire life cycle; even after the end-user. For example, after disposal, the packaging should be designed to be recycled or reused in such a way that minimises the contamination of the environment. Nowadays, there are several options for recovery design that have been invented in the food industry, where recyclable and reusable packaging is still on the list of the environmental options of packaging material. These innovative designs of the environmental dimension are represented by biodegradable, degradable and compostable packaging.

Biodegradable plastic uses the minimum amount of fossil fuel resources. This packaging is as useful as conventional packaging but is completely degraded in soil by microorganisms (anaerobic) or by composting (aerobic) processes (Jayanth et al., 2018). While degradable and compostable packaging could be defined as the same as biodegradable, but they are produced with more renewable natural resources such bioplastic (a plant-based plastic) and disintegrate easily in the natural environment (Bahramian et al., 2016). Science-based researchers and practitioners such as packaging designers have paid less attention to the use of these terms, and this has created confusion among stakeholders. For example, Spaccini et al. (2016) report that biodegradable packaging is made up from starch-based polymeric composite, while Jayanth et al. (2018) believe that production of biodegradable packaging requires fossil fuels with a different structure than the conventional plastic. Even though there is an emerging issue regarding the terminology of these three types of sustainable

packaging, more research continues to improve the sustainability features of these materials.

2.5.2 The social dimension of sustainable packaging

The social dimension of sustainable packaging has received less attention than the environmental dimension. However, this does not mean that this dimension must be overlooked because the key success of sustainable packaging is the ability to access, balance and transform these three dimensions. The social dimension deals with packaging functions that can satisfy the sustainable needs of our society. Packaging function by definition is an attribute of the packaging serving a specific role for end users in terms of food safety and effective communication to consumers. There are three distinct categories of packaging from consumer's perspectives explored by Lindh, Olsson and Williams (2016), which are a protective role, to facilitate handling, and communication. These functions of packaging are socially important for consumers and directly or indirectly enhance the quality of their lifestyles.

The primary function of packaging is to offer effective protection to its contents. This function has the greatest potential to ensure that food purchased and consumed is safe. The ability to protect food is an essential function of a sustainable packaging for consumers, as is often taken for granted by them when environmental friendly packaging becomes the topic of interest (Lindh et al., 2016). Consumers generally assume that this protective function comes 'by default' when they are buying any food or drink products. Functions like 'no leakage' or 'best before date' views are the basic requirement, even if consumers do not mention these attributes (Lofgren & Witell, 2005). The protective role of packaging usually does not generate any satisfaction to the consumer if it is fulfilled, but it will result in a high level of dissatisfaction when it is not fulfilled (Lindh et al., 2016). The existence of packaging is to shield its contents from physical contamination from the environment, and this function must be maintained for the development of sustainable packaging. For example, packaging that fails to protect its content will cause food safety issues and contamination in the environment (Gronman et al., 2013; Nordin & Selke, 2010; van Dam & van Trijp, 1994).

The social dimension also influences the recovery design of recycling. This is because consumers' preferences to save food have altered the way manufacturers design their packaging. Food producers have focused on individual packs or mini packs to reduce

food waste, and to cope with the demand for a consumer's social life⁸. However, producers were unaware that to produce mini packs they needed multiple layers of different recyclable packaging materials which were challenging to recycle in the same process without contaminating the end-product (a by-product of recycling) (Benton Jr., 2015; Robertson, 1990). For example, multiple layers of chip bags would make recycling impossible due to lack of facilities to separate these layers in a recycling centre (Wu, 2014). An additional example is paper-based coffee cups, which are non-recyclable due to the plastic-layered design. Even though material used to make packages is recyclable, when it layers with other materials, it becomes very difficult to reprocess at the end.

From a social sustainability perspective, the environmental and social dimensions may be in conflict because sometimes it is necessary to increase the amount of packaging material at the expense of the environmental impact. This could happen because even if the best option is to come up with a better design given the same amount of packaging material, some consumers need extra features to facilitate the handling and use of packaging during purchasing, transport and consumption of food. For example, 'easy to open' and 'grip-ability' packaging are one-dimensional function that gives satisfaction to the consumer when fulfilled (Lofgren, Witell, & Gustafsson, 2011). These functions require extra packaging material to be implemented on the packaging, but they help a significant number of consumers to cope with health problems such as reduced strength of their hands (Lindh, Olsson & Williams, 2016). The physical look of sustainable packaging matters because packaging style enables or restricts consumers' pro-environmental behaviour.

Packaging styles include size, shape, label layout and other utility characteristics that add value to sustainable packaging. For example, additional physical-chemical protection, such as resealable packing gives extra protection and freshness to a food product as well as avoiding food contamination after having opened the product (Jinkarn & Suwannaporn, 2015; Wikstrom et al., 2014), and screw caps and top flip openings are prompted by consumers. The development of sustainable packaging is also challenging because consumers evaluate its quality not only when making a purchase but also when consuming the food product (Steenis et al., 2017). A package that fits consumers' basic requirements and meets their needs during and after use it is the primary driver of any product sold in the market.

⁸ Consumer's social life is everyday lives such as home composition and condition, working hours, commute activities where a packaging aspect can provide convenience is important to them (Lindh et al., 2016).

Packaging is the most appealing strategy used by most food producers or manufacturers to deliver environmental messages at the point-of-purchase of sustainable packaging to consumers. Without that communication on the package label, the sustainability attributes are unclear to the consumer (Jerzyk, 2016). For example, it is difficult or almost impossible for the consumer to determine whether the packaging material is compostable or recyclable without any information on the packaging. The communicative role of packaging is essential to help consumers utilise and handle the product in an environmentally friendly manner. The attractive quality of packaging such as the label 'recyclable material' provides satisfaction to consumers, but it does not cause dissatisfaction if this is not fulfilled (Lindh et al., 2016). Moreover, if scientific information used on packaging material by producers is not understood by consumers, this will negatively affect their purchasing intentions. Some packaging materials appear to be generally known only by manufacturers, especially plastic, because consumers usually depend on this information to dispose of the material correctly (Meise et al., 2014). For example, the triangle symbol called 'PET 1' usually appears at the bottom of soft drink bottles, and consumers might never know the meaning of this symbol without producers adding extra explanation. Only consumers concerned about environmental issues may look for the meaning of these symbols.

2.5.3 The economic dimension of sustainable packaging

The economic dimension of packaging is as important as the environment and social dimensions. However, the growing interest in the economic aspect of sustainable packaging seems only to relate to understand how consumers' purchasing behaviour is influenced by price increases determined by sustainable packaging. For example, sustainable packaging for organic food is likely to be more expensive than organic products marketed with conventional packaging, and thus fewer consumers might afford or be willing to buy these products (Magnier & Crie, 2015). Thus, as far as this study is concerned, sustainable packaging offers non-economic benefits to consumers.

A further aspect of the economic dimension relates to sustainable packaging as a marketing opportunity both to food producers to differentiate their products and to waste management businesses to enter new markets. For example, the recovery design of sustainable packaging helps manufacturers and waste management businesses to recycle or reuse packaging after consumers' disposal. This produces less solid waste, requires less energy to process packaging material and is cost saving. Cost saving is also achieved by the fact that all activities for recycling are easy

to manage in terms of cleaning and keeping at a minimum level the hazardous materials leaching out from landfills and contaminating groundwater and soil (Suer, Wik & Erlandsson, 2014). Landfill and incineration centres for sustainable packaging would be cleaner and less expensive than conventional infrastructures because of packaging waste reduction and reduced distribution and production costs for producers and or retailers.

2.6 In case of dairy milk in the UK: Consumers' preference attributes of milk packaging

Dairy milk is one of local food commodity in the UK. It has been consumed almost daily in every household. DEFRA recorded that 1,328m litres of milk deliveries made per day for the entire UK. The agri-food and drink industry is focusing on milk production due to the amount of milk consumption and the future of economic growth in the region (Hollywood et al., 2013). Moreover, milk claims to be healthy food that transport macro and micronutrients to the human body (FAO, 2013). With this perspective in mind, it is crucial to portray the positive image of milk packaging from an environmental perspective. The packaging that sustains the environment as well as brings benefits to the consumers.

In the case of milk packaging, the evolution from glass-bottled to plastic packaging seems to be more cognisance of adverse environmental impacts by consumers. They viewed traditional packaging of milk can assist in reducing waste (Neill & Williams, 2016). A packaging that gives no effect to the environment will portray the benefit of consuming dairy milk. It does not only make consumers healthy but the environment as well. As limited research has been conducted into consumer attitudes of this commodity food packaging, the study aims to explore consumer views on various aspects of sustainable packaging, and fresh milk serves as the food product to communicate with the participants throughout the data collection. The sustainable packaging of raw milk assists in finding out the preferable type of sustainable packaging by consumers, and it also helps consumers to focus on the specific type of local food rather than food product in general.

Current literature evaluating packaging design for milk significantly highlighted that consumer's preferences seem differently from one study to another. In general, the foremost concerned of milk packaging is meeting the basic food packaging needs (e.g. containing and protecting), while other packaging attributes come in second in terms of priority. The packaging must be followed the safety standard as a public health and a

trade policy issues in order to maintain the shelf-life and quality of the milk (Ghosh, 2016; Kuhl, Gassler & Spiller, 2017; Meurer et al., 2017). Besides the immediate priority of the milk itself and price, consumers appear to be concerned on several important attributes of milk packaging when making their purchase decision. There are form, communication capability, function of the packaging and physical appearance of package. All the chosen attribute preferences are closely related and depend on the personal background of consumers.

Firstly, the form of milk packaging surprisingly one of the influential factors that help consumer decides to purchase milk product in the market. Form of packaging relates to the physical design of the packaging like size, shape and features. In China, Chinese consumers tend to consume dairy milk in small packages, often in single-serving plastic bags, plastic bottles, or small cartons as their predominantly factor of milk is food safety (Wang, Mao & Gale, 2008; Yin et al., 2016). Meanwhile in the UK, volume of consumption and size of household affected on how household members purchased fresh milk in the market. For example, big household and heavy users tend to buy larger pack sizes or bulky sizes of milk packaging. In comparison to the single or light users preferred to purchase small cartons of milk (2 pints). Furthermore, the primary concerns of milk packaging shape are whether the packaging fitted easily into the refrigerator and able to be stored with minimal hassle at home. If consumer found the shape of milk container to be awkward, difficult to use or cause wastage and spillage, they might be reluctant to buy it. Last but not least on the form attribute, milk container with in-built handle found to be well-accepted by consumer in the UK. It helps the consumers to lift and carry it easily when buying and using; even though, some consumers expressed concern that is not child-friendly due to the bulky size and difficulty to open the containers without help from adults (Hollywood et al., 2013; Valajoozi & Zangi, 2017).

Secondly, the technical function of the milk packaging also an important attribute that persuades consumers to purchase a dairy milk product. It is included the opening, resealing, disposable capability, packaging material and protection — packaging material in the UK surrounding within glass, cardboard and plastic. Plastic packaging of milk is the most favourable as it more durable than the glass and had less risk of breaking. Consumers agreed that the plastic containers were less likely to leak due to the screw-top cap and the product itself was protected (Hollywood et al., 2013). While, Chinese consumers tend to consume dairy milk in single-serving plastic bags and plastic bottles, rather than in carton or cardboard form (Wang, Mao & Gale, 2008). Cardboard viewed negatively by the majority because it did not keep the product as

fresh as other types of packaging, they could not see the product through the packaging, and it is not fresh milk but treated milk like UHT milk . This fear of uncertainty of unknown contents of the package affected their purchase decision. Other forms of technical function like open-ability and reseal-ability of packaging are the attributes that the majority of consumers displayed a positive attitude towards milk containers as their screw-top cap meant the product could be resealed and kept fresher. Moreover, a senior-friendly screw-top cap is generally accepted due to difficulty regarding strength and grip required in opening the package (Hollywood et al., 2013).

Thirdly, the appearance of the milk packaging such as colour, font style, image or picture may perhaps affect consumers' milk consumption. Packaging must contain such elements that evoke an immediate positive reaction in the recipients and encourage them to pick it up. If a particular person decides to look at the packaging more closely after it has attracted and retained their attention, they make a more or less detailed analysis of the elements including non-verbal design (e.g. graphic design, logo, awards, etc.) (Baruk & Iwanicka, 2016). In the UK, heavy milk users reinforced that the images of a cow or countryside display the origin and the naturalness of the product in their mind; while some discussed unnecessary need for those images. Meanwhile, light milk users found that images on milk packaging are boring, bland and uninspiring (Hollywood et al., 2013). In supplemental factor to image, colour of background label is most influential factors that drive consumers on milk purchasing, especially young consumer. In Iran, young consumers would attract to the bright and noticeable colour of milk packaging label, while adults are keen to the product history and knowledge based on their experience and reading (Valajoozi & Zangi, 2017). Same goes with the illustration factors on the label could be considered to be related to this argument as well. Besides, the significance different findings of illustration could be supplemental to the colour factor findings. Besides that, some milk containers use colour to differentiate the product that will help consumers to select the milk faster than before. Example, colour-coded system in the UK of milk shows that blue is whole milk and green is semi-skimmed milk. This attribute is very much appreciated by consumer (Hollywood et al., 2013). As same as, Gelici-Zeko et al. (2013) highlighted that Dutch consumers strongly influenced by colour of milk packaging. If new colour added to the dairy product range would draw attention and doubt impressions among the consumers.

Lastly, the communication capability of milk packaging is the most essential attribute that significantly proves to effect consumer milk selection. Communication features

such as verbal information of the content, affiliation, certification and mandatory nutritional content and expiry date of the product are among the information usually found on the packaging. Besides communicate and provide information, food producers are building trust on consumer through the labelling. In Germany, consumers see transparency and traceability of milk products as critical. The more transparency shows on the label, the more willing consumer to buy the milk (Kuhl, Gassler & Spiller, 2017). Information on the source of ingredients, origin country would help consumer to make better decision on their purchases. However, food producers often take advantage of information asymmetry between consumers and themselves to engage in opportunistic behaviours, such as fraud (Yin et al., 2016). Consumers tend to lend greater trust to independent third-party certification bodies such as organic certification to reduce information asymmetry.

Certification labelling schemes have become essential means for producers to prove food quality to consumers (Yin et al., 2016). Even though the certification has relatively little influence on the consumers, OPRL symbol, health logo, fair trade and carbon footprint are still needed to build trust in consumers of the milk packaging. For example, consumer's preferences of more ecological symbol of milk packaging grew with the consumers' age and educational level (Baruk & Iwanicka, 2016; Gelici-Zeko et al., 2013). In contrast, while consumers show awareness of nature protection and animal welfare, but comparatively low price is more important when buying the milk (Kuhl, Gassler & Spiller, 2017). Despite all the mentioned attributes, price is still the primary attribute that gives the impact on their milk consumption, then others' follows. Overall, although packaging appears to be a relatively minor concept within the overall brand strategy, consumers actually rely more on indirect indicators to replace real product quality cues when completing their purchases decision. Consumers evaluate product according to their expectations and their evaluation, where a product has complied with a person's expectations to satisfactory degree, form the basis of their decision to buy the product.

2.7 Consumers' attitudes and purchasing behaviour towards sustainable packaging

While there is a huge literature regarding consumers' attitudes and purchasing behaviour towards green food products (e.g., Ercilla-Montserrat et al., 2019; Laureati et al., 2013; Nuttavuthisit & Thorgersen, 2017; Schlegelmilch et al., 1996; Vermeir & Verbeke, 2008; Zhao et al., 2018), to date few studies have investigated this issue in

relation to sustainable packaging. However, it seems that the emergence of environmental problems is likely to have shifted the consumer demand for sustainable packaging to the right. Study indicated that consumers respond positively to sustainable packaging because they are becoming more aware of environmental issues. Consumers appear to be concerned with the product life cycle, packaging materials and the environmental impacts of food packaging when making their purchasing decisions (Jerzyk, 2015). Approximately 42% of European consumers claimed that they would consider switching to green packaging for their food choices if these products were proved to be environmentally superior to the conventional alternatives (Kassaye & Verma, 1992). Moreover, many stakeholders in the food industry have been making efforts and creating initiatives to elevate sustainability from an abstract goal into an immediate priority. Even though consumers have indicated positive attitudes on sustainable packaging development, relatively little is known about their attitudes and purchasing pro-environmental towards that packaging. Discussions of these aspects related to green packaging are relatively scarce even if they are extremely important to optimise designs and to improve packaging systems taking into account the three dimensions of sustainability (Nordin & Selke, 2010).

There are several aspects of a consumer's attitude emerging from sustainable packaging studies conducted so far. First, consumers' attitudes towards the price of sustainable packaging indicate that this attribute influences purchasing behaviour strongly, while the eco-friendly attribute might be not considered so important. Consumers' choice in terms of packaging is a purely economic decision, and they are very sensitive to price. Indeed, consumers tend to balance expected costs and benefits. These costs may include the price of the product, the time spent on finding the product, and the distance travelled to purchase the product (Orzan et al., 2018). According to Thøgersen and Olander (2003), green packaging in Denmark is not extraordinarily expensive, but conventional packaging is extremely cheap, and consumers generally cannot afford to buy only green food products. Moreover, responsible consumption of food products is often perceived as a time-consuming action, economically unfavourable, and stressful (Biswas & Roy, 2015). Even if the perceived costs exceed the perceived benefits, consumers will not act to preserve the environment even if they are sympathetic towards the environment (Radulescu & Radulescu, 2012).

Second, consumers' knowledge also plays an important role in their attitudes toward sustainable packaging and lack of information is one of the main barriers to adopting sustainable behaviour (Orzan et al., 2018). Consumers make a packaging choice when

they have the knowledge or are willing to seek information about buying eco-friendly products. Nordin and Selke (2010) found that a high percentage of consumers are familiar with the sustainable term (40%) (e.g. recyclable, biodegradable) especially among young respondents in European countries. However, they also found that when consumers are unfamiliar with the terminology and the concept of sustainability, they find it difficult to distinguish between sustainable and conventional packaging. The majority of consumers appear to be familiar only with the word 'recyclable', and less than 36% know the meaning of all sustainable packaging terms such as 'compostable', 'biodegradable' or 'ecolabel' (Young, 2008). The fact that recycling is the most well-known term in food packaging is also confirmed in other studies. In 1970, the introduction of mass kerbside recycling programmes in five EU countries (France, Germany, Portugal, Romania and the UK), had made the public aware of the importance of recycling because of the long and wide exposure of consumers to this term (Ferreira da Cruz et al., 2014). In Romania, a fairly large proportion of consumers prefer packaging of paper, glass and cardboard because of they are aware that these packaging materials easy to recycle and have less impact on the environment (Orzan et al., 2018). Magnier and Schoormans (2015) tested how packaging attributes affect consumers' perception of food items as more and more food producers are developing sustainable packaging. They found that French consumers with high environmental consciousness were sensitive to incongruent visual appearance and sustainability claims. Also, in the USA consumers' perception is influenced by a lack of knowledge about the concept of sustainability, and ignorance about terminology can result in inconsistent attitudes towards sustainable packaging (Nordin & Selke, 2010). On the other hand, knowledge of innovative sustainable packaging also appears to worry consumers. Orzan et al. (2018) state that even if consumers are aware of sustainable packaging benefits, they assume that new sustainable packaging requires both a higher disposal effort at home and greater storage space for household waste. This is because innovative sustainable packaging materials appear to focus on biodegradable and other disposal options (e.g. compostable), and extra effort might be required to sort the packaging waste after use (Herbes, Beuthner & Ramme, 2018).

Third, despite the fact that consumers are becoming positive about eco-friendly packaging and supportive toward sustainable marketing, they are reluctant to accept any modification of the primary functions of packaging, such as protective and handling roles. Changes in the packaging style that could shorten the shelf life of food and affect its appearance are not well-accepted by consumers (Jimenez-Guerrero, Gazquez-Abad & Ceballos-Santamaria, 2015). For consumers, the food inside the packaging is

the most important component of their buying intention, while packaging helps to maintain the food quality. For example, there has been a controversial issue of shrink-wrap for cucumbers in the UK. Even though some authorities dislike the use of plastic packaging, consumers seem to appreciate it due to the sanitary look of this fresh produce (Aldridge & Miller, 2012). This means that, even if sustainable packaging, for example thin paper, has a low negative environmental effect because it decomposes naturally, its use could be unsuitable because the food might be easily spoiled. As a result, the use of sustainable packaging in conflict with food safety can increase food waste. In Sweden, consumers also argue that 'too much packaging' for the quantity is a major factor of waste accumulation and food losses through the physical degradation of food (Williams et al., 2012). An important aspect for manufacturers if they want to market innovative eco-friendly packaging successfully is consumers' acceptance of new technology. For example, a study of nanotechnology in food packaging to sustain the food quality suggested that consumers have a very low probability of trade-offs between their environmental concern attitudes and acceptance of new technologies (Matin et al., 2012). Uncertainty about the benefits of the new technology to improve the environment health appears to be the reason for some reluctant pro-environmental purchasing behaviour. Although consumers can be well-informed about the benefits of innovation towards preservation and quality of the food product and show support for the invention of innovative sustainable packaging, but they are unlikely to purchase it (Chen, Anders & An, 2013).

Finally, purchasing behaviour seems to be influenced by the socio-demographic characteristics of consumers, but the few studies conducted so far report contrasting results. Mitchell, Topic & Munroe (2018) found that, in the UK, willingness to buy sustainable packaging varies in relation to age and gender. Participants older than 55 and females were willing to pay a little more than younger and male respondents for green packaging. However, in Indonesia young participants were willing to pay more than those who were older (Auliandri et al., 2018). In Romania, Orzan et al., 2018 found that participants were not willing to buy more for sustainable packaging because they could not afford it, but in France, Magnier and Crie (2015) found participants were likely to be willing to pay more for sustainable packaging. A similar study in Sri Lanka also found that an increase in income is more likely to increase consumers' willingness to pay higher prices for sustainable packaging (Madushanka & Ragel, 2016). According to Singh and Pandey (2018), consumers' pro-environmental behaviour and purchasing intentions relating to sustainable packaging seem to be influenced by six factors. These factors are novelty value of the packaging (e.g. biodegradable, safe for

environment), functional value (e.g. simplified packaging, resealable, reasonable pack size), economic value (e.g. leakproof, product safety), symbolic value (e.g. logo, disposal instruction), peer pressure and personal norms (Singh & Pandey, 2018). This empirical study identifies a positive relationship between these values and consumers' willingness to pay a premium price for sustainable packaging. Nevertheless, as far as this study is concerned, only a few other studies have been identified that investigate the differences between consumers' willingness to pay for sustainable packaging and other socio-demographic characteristics.

Furthermore, empirical research also shows that when consumers make their purchasing decisions, they compromise between environmental attributes and personal benefits in the formation of their preferences. The most influential attributes of consumers' purchasing decisions appear to be freshness, quality preservation and convenience, while environmental aspects of packaging play a secondary role (Nordin & Selke, 2010). Although consumers favour environmentally safe packaging, the primary purpose of their purchases is to consume food products of decent quality. Rokka and Uusitalo (2008) concluded that even the most pro-environmental consumers do not choose any food product merely on the basis of environmental benefits, but rather on the trade-off between personal needs and eco-friendly attributes. In addition, palate preferences and prices are other significant factors that influence consumers' trade-off with sustainable packaging attributes. For example, Seo et al. (2016) found that consumers are willing to trade-off almost all product attributes in favour of sustainable packaging of food products, except for taste and price. In food markets, consumers usually demand a product that is tasty and affordable while sustainable packaging can be considered the bonus criterion of their choices.

However, it seems that so far only two studies have used conceptual frameworks to explore consumers' pro-environmental behaviour towards sustainable packaging. Prakash & Pathak (2017) used the theory of reasoned action to explore how attitudes and subjective norms influence consumers' buying intention of green packaging. They found that in India personal norms and environmental concerns have a positive impact on a willingness to buy eco-friendly packaging. These results were corroborated by Auliandri et al. (2018), who employed the theory of planned behaviour to explore how attitude, subjective norms and perceived behaviour control influence consumers' purchasing intention of green packaging. They found that personal norms regarding concern for the environment, knowledge about green packaging and beliefs about the positive consequences of using sustainable packaging were impactful features of consumers' purchasing intentions

This review of the literature has shown that further research investigating the four aspects of consumers' attitudes towards sustainable packaging is necessary to supplement knowledge in this area. It is important to seek deeper information about how consumers perceive every aspect of sustainable packaging attribute to ensure the success of any sustainable products in the future. There are not many studies focus on the willingness to pay of consumers the additional cost for sustainable packaging in a monetary amount. Previous studies focused on consumers' buying intentions and influential factors to make the purchase. However, little is known about how much consumers are willing to trade with their environmental consciousness. Moreover, scientific research has developed and explored new sustainable packaging materials which potentially increase the options of sustainable packaging development, but there is a lack of studies focusing on the trade-off between innovative sustainable packaging and consumers' valuation on each of the packaging attribute. Understanding the most important attribute of innovative sustainable packaging for consumers needs to be explored fully to overcome any marketing failures of this packaging.

Additionally, another area where knowledge is limited the impact of socio-demographic factors on consumers' willingness to pay for innovative sustainable packaging. Socio-demographic factors such as income, age and gender were found previously to affect consumers' attitude on sustainable packaging and drive their green purchasing behaviour. Therefore, it is worthwhile to explore further the influence of these factors on consumers' attitudes towards innovative sustainable packaging. Finally, the extent to which consumers value innovative sustainable packaging is under-explored in studies using psychological framework methods. Besides socio-demographic factors, psychological values such as environmental values, knowledge of sustainable packaging and personal norms might be critically important to consumers' attitudes towards willingness to pay for innovative sustainable packaging.

The identification of these knowledge gaps throughout this chapter leads to the following questions, which guide this study:

1. What are the most preferred attributes of innovative sustainable food packaging that consumers are willing to compensate when choosing sustainable packaging alternatives?
2. In what way do environmental values, beliefs and norms will influence consumer's willingness to pay for pro-environmental purchasing behaviour?

3. How much are consumers willing to pay for new innovations in sustainable food packaging and what are its attributes?
4. Which socio-demographic factors affect consumers' attitudes on choice behaviour when making their pro-environmental purchasing decisions relating to of new sustainable packaging?

This chapter has reviewed the literature on the food packaging and its waste that leads to the development of sustainable packaging innovation. Through the literature, it identified areas where further research is needed and established the research questions to be addressed in this study. The next chapter will be the qualitative research methods on the sustainable packaging innovation and the implication of the results for further study.

CHAPTER 3

QUALITATIVE STUDY: IN-DEPTH INTERVIEW AND FOCUS GROUP

3.1 Introduction

This chapter presents both the qualitative techniques (in-depth interviews and focus groups) used in this study and their results, which were used as input to develop the quantitative study presented in chapter four. Both techniques were used to get insights about innovative sustainable packaging, where in-depth interviews were used to collect information from stakeholders of the UK industry, while focus groups were conducted with consumers. As a result, the first section will describe and present results of the in-depth interviews, while the second section methods and results of focus groups. Finally, also highlight how findings of qualitative research fit into the main component of this study where a combination of economic and psychological models will be used to explore consumers' preferences towards innovative sustainable packaging.

3.2 In-depth interviews

In-depth interviews are one of the most popular forms of qualitative research methods that are used to obtain detailed information about the topic of interest (Adler & Clark, 2011). This technique was chosen to gather information from stakeholders of the UK food packaging industry in order to understand what kind of innovative sustainable packaging they might introduce on the market. The research protocol of the in-depth interviews was structured around starting open-ended questions, which contained memo points to facilitate the discussion with experts. Table 3.1 shows some questions were asked while the whole in-depth interview research protocol is shown in Appendix 2. As it can be seen from Table 3.1, these questions had the scope to explore issues, trends, policies and sustainable innovative solutions that the food packaging industry is facing, following and adapting to counteract the current crisis of unsustainable packaging.

Table 3.1: Initial questions of in-depth interviews

Initial open-ended questions
<p>1. In general, what are the trend and issues of current food packaging in the market?</p> <p>Memo point:</p> <ul style="list-style-type: none">○ <i>Trends and issues in food packaging 2016:</i><ul style="list-style-type: none">▪ <i>Material substitution</i>▪ <i>Convenience (i.e. Lightweight, excessive packaging)</i>▪ <i>Label transparency and trust</i>▪ <i>Sustainability logo like Carbon footprint, recycling, etc</i>▪ <i>Sustainability efficiency</i>▪ <i>Healthy living (i.e. natural ingredient formulation material)</i>▪ <i>Others</i>
<p>2. What is the current packaging policy that your company used for food-contact packages (primary packaging)?</p> <p>Memo point:</p> <ul style="list-style-type: none">○ <i>Type of packaging materials for different group of food product</i>○ <i>Choose the right packaging material for right product</i>○ <i>Label specifically the materials used</i>○ <i>Maintain two-way communication with consumer information label</i>○ <i>Partner with local packaging material supplier</i>○ <i>Describe other ways the company monitors and manages packaging policy</i>
<p>3. Does the company have an environmental policy for food-contact packaging through the sustainable development policies? How far your company apply this policy?</p> <p>Memo point:</p> <ul style="list-style-type: none">○ <i>About use of plastic in packaging because paper box or metal generally known to be recyclable</i>○ <i>Develop a recycling program or packaging</i>○ <i>Formed an environmental or waste audit regarding post-used packaging</i>○ <i>Practice energy reduction when possible</i>○ <i>Supplier for packaging; local or import</i>○ <i>Assessment and review opportunities for improvement and changes to packaging in accordance with goal of sustainability</i>○ <i>Other- what other plans do you have in place for promoting the sustainable packaging efficiency</i>
<p>4. Do you have any plan for new potential materials to replace the current packaging of the company?</p> <p>Memo point:</p> <ul style="list-style-type: none">○ <i>On specific type of food product:</i><ul style="list-style-type: none">▪ <i>Fresh produce (perishable): Meat? Poultry? Vegetables? Fruits? Bakery?</i>▪ <i>Dried (Non-perishable): Nuts? Dried fruits?</i>○ <i>Purchase “green” materials (recyclable, reusable, non-toxic, degradable or made from 100% post-consumer recycled material)</i>○ <i>Label the materials used</i>○ <i>Partner with local sustainable supplier</i>○ <i>Utilise supplier who shares sustainability commitment</i>○ <i>Partner with recycler who share sustainability commitment</i>○ <i>Others- describe other ways the company monitors and manages packaging policy</i>○ <i>Follow the trend:</i>

-
- *New material such as biopolymer (plastic from renewable sources like plant commodities, microbial by-product or biomass)*
 - *Encourage recyclable, reusable and degradable materials*
 - *Flexible characteristics: lightweight, minimise cost, transport or delivery friendly*
-

5. If the company has plan for sustainable development of packaging, would you please elaborate on how **that sustainable package** will be designed with an extension of traditional design considerations in mind?

Memo point:

- *Outline the **main design strategy or concept** that might be employed to achieve the sustainable vision:*
 - *Design for cradle-to-cradle system*
 - *Resource recovery packaging*
 - *Improve foodstuff characteristics as well packaging like active packaging or intelligent packaging*
 - *Others- describe what the company does to minimise the environmental impact and cost associated with packaging*
-

The interviews with food packaging experts in food businesses and academics were the first approach of this study procedure. This method seeks to find out any current innovative food packaging that the industry is trying to introduce on the market to satisfy the needs of consumers who are looking for sustainability. Interviewees were required to identify the main attributes of sustainable packaging that their companies believed would benefit consumers and the environment while maintaining their businesses profitable. Information collected with in-depth interviews will be utilised to design both the focus group research protocol described in the next section and the consumers' survey presented in the next chapter.

An in-depth interview research protocol was prepared and approved by the ethical committee of the School of Agriculture, Policy and Development of the University of Reading (see Appendix 1). Adler and Clark (2011) stated that constructing interview questions ahead of time makes the interview process smooth and ensure full coverage of all topics of interests in every interview. Therefore, questions covering essential aspects of food packaging were organised according to the following topics: trend and issues of food packaging, policy implementation, recent styles on sustainable food packaging, and consumer acceptance of sustainable packaging. These open-ended questions were developed based on previous studies and current trends of the food packaging industry and had the scope to capture more in-depth information from the interviewee. For instance, aspects of sustainable packaging regarding the material health of sustainable packaging had an open-ended question and bullet points (memos for the facilitator) to trigger the discussion around key point as shown hereafter:

Material health: *Is the packaging material safe for the consumer and environment?*

- *Special logo to emphasise the sustainability?*
- *Know the potential health and environmental impact.*
- *Know the chemistry of the material and the food content.*
- *Examples?*

The in-depth interview research protocol was piloted interview with a food packaging expert and food scientist of the School of Food and Bioscience of the University of Reading. The interview was audio-taped and took approximately one hour. The piloting was paramount to judge whether questions were appropriate and as a consequence to re-order and re-word when necessary. Moreover, the pilot allowed the researcher to familiarise with the questions, to capture initial trends, and to identify follow-up questions and to understand how to encourage interviewees to answer the question fully (memos for the facilitators).

3.2.1 Recruitment and data collection

Potential interviewees were identified randomly from online websites, list of packaging and food companies, university experts and non-profit organisations that collaborate with the food industry. Participation in this study on behalf of potential interviewees was sought initially via emails and telephone calls and then applying a snowballing sampling method. The snowballing technique was applied at the end of the in-depth interview; where the participant was asked to suggest contacts of potential experts for this study.

Interviewees were people working in the industry and academia, and because they were very busy the recruitment was very challenging, and almost all the in-depth interviews were conducted via phone. At the beginning of each interview session, participants were given a short briefing about the study, ensured confidentiality and asked permission to record the interview. These interviews were conducted from July to November 2016 and in line with the scientific qualitative research method, and the recorded interviews were manually transcribed verbatim into written words before being coded and analysed with NVIVO version 11.

3.2.2 Analysis and results of the interview data

A total of four interviews were conducted in the UK with two major retailers, a packaging supplier for major retailers and a non-profit organisation of the packaging and food waste sector. Qualitative data were organised and analysed using NVIVO, where the interviewee's responses were coded into relevant aspects of food packaging and the development of sustainable packaging. The generation of the initial list of codes was mostly based on the previous literature and contextual sense of the qualitative data. Each interview was examined more closely again by revising the interviewee's transcriptions based on the interview questions attached in Appendix 2. For instance, the section capturing the nine-preliminary effective design quality of sustainable packaging in the question (Question 6 of interview protocol in Appendix 2) was set as guidance of the coding process of interviewee's answers. If the answer was related to '*lightweight of the packaging*', it was coded under sustainability benefits and technical performance. Finally, the interviewees' responses of all four interviews were grouped into fifteen initial codes, as shown in Figure 3.1 (coloured words).

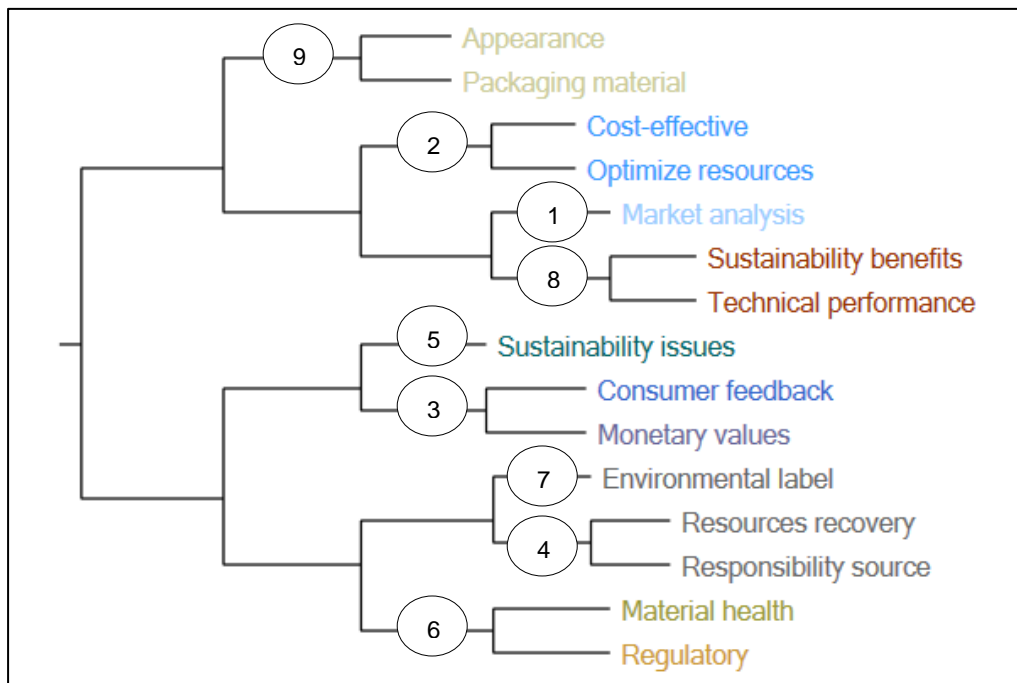

Figure 3.1: Fifteen initial codes clustered by word similarity.

The analysis continued with the initial fifteen codes generated from the interview data, then clustered into nine child codes, as shown in Figure 3.1. The use of this clustering technique generates ideas and links the codes into deeper relationships (Bazeley & Jackson, 2014). Clusters set as salient characteristics were then assembled into three-

parent themes based on different perspectives of food packaging development. These parent themes were named with three major aspects food systems: 'marketing and economic', 'policy' and 'packaging design'. The first two themes cover specific trends of current food packaging and its implementation on the market, while 'packaging design' deals with any innovation of sustainable packaging that makes food products competitive on the market (FAO, 2013).

3.2.3 Identification of context-specific themes

Data analysis of in-depth interviews was conducted through two steps. In the first step, a cluster analysis linked fifteen initial codes on the basis of word similarity. The word similarity clustering technique grouped together with similar words that appeared in each of the fifteen initial codes (known as nodes by NVIVO) (Bazeley & Jackson, 2014). These codes were then used to identify 9 clusters, as shown in Figure 3.1. In the second step, these 9 clusters were grouped into the three parent themes mentioned previously. The three parent themes were analysed and presented in 'word cloud' of word frequency. Word frequency analysis was used to visualise the most frequently occurring words in every theme (Bazeley & Jackson, 2014). Technically, the font size is used to indicate the frequency of words, so the larger the word, the more frequent the word used appears during the interview. The highest frequency words appeared in every child code within the parent theme were displayed in Table 3.2. The result of this analysis visualised into word clouds will be discussed in the next section.

Overall, in all themes in Table 3.2, words related to recycling such as 'recyclable', 'recycle', 'recycling', 'recycled' and 'recyclability' appears in a high frequency of all themes. The pool of recycling terms from the interview transcription confirmed that food producers and retailers were pushing on the recyclability of packaging material for two reasons. First, the consumer is familiar with the terms in of the sustainable plan and can relate recycling contributes to the better living environment as mentioned previously in a study conducted on social aspects of sustainable packaging by Nordin & Selke (2010). Second, according to the interviewees, there is a regulatory requirement of food packaging in the UK legally quantified to upgrade the recyclability of food packaging in the market rather than other sustainable options of packaging material. Therefore, recycling packaging is a major requirement of the food industry currently in the UK.

Table 3.2: Derivation of themes, codes and plausible words in codes

Themes	Main Codes	Words in codes
Marketing and economic	1. Market analysis	<i>Life cycle assessment, pressure, acceptability, influence.</i>
	2. Economic efficiency: cost-effective, resource optimisation	<i>Weight reduction, reduce/light, minimise layers, modification cost.</i>
	3. Consumer demand value: consumer feedback, monetary values	<i>Recyclable, expensive, ease/economic, communication, rebranding.</i>
Policy	4. Resources competency: resources recovery, responsibility source	<i>Recycle/ recyclability, recycling/ recycled, resource maximisation, certified material (safe forestry), functional design.</i>
	5. Sustainability issues	<i>Disposal route for degradable, waste stream, scarcity of food, consumer confusion, expensive facility modification.</i>
	6. Regulatory compliance: material health, regulatory	<i>Recycling policy, certified recycling scheme, information on label, guidelines for post usage, CSR policy.</i>
Packaging design	7. Environmental label	<i>Recycling scheme (OPRL), information of product, sustainable logo, traceability.</i>
	8. Sustainability execution: sustainability benefits, technical performance	<i>Extend shelf life, lightweight, recyclable, convenience, bio/oxo-degradable, compostable, reduce wastage.</i>
	9. Visible appearance: packaging material, appearance	<i>Fossil fuel-based plastic, plant-based plastic, glass, paper, ease/ready, flexible pouch, carton/ box/ can/ jar/ tray/ pod, attractive / seasonal, vacuum pack.</i>

3.2.4 Results

3.2.4.1 The marketing and economic theme

The marketing and economic theme is an important aspect of sustainable packaging as it is closely related to consumer demand for more environmentally friendly packaging. This is because the efforts of food producers and retailers to develop sustainable food packaging mainly depend on the consumer request to sustain the competitive market of fast-moving consumer goods (Kalkowski, 2007). Figure 3.2 shows that 'recycle' and 'reduction' are the most recurrent words of these themes and seem to be placed at the intersection of two horizontal and vertical imaginary axes in the mind of stakeholders. The horizontal axis is depicting more a dimension related to the development of the product taking into account consumers' view. The 'pressure' and 'influence' exerted mainly by consumers strongly direct the food producers to reassess their packaging prior they market their product. Modification of current packaging was perceived as challenging because of economic aspects. The effort to apply life cycle assessment analysis mentioned by interviewee ensures that the packaging causes no harm to the environment but provide more wellbeing through mostly the 'recycle' aspect. Interestingly, even though consumer desire for recycling is high for food packaging, interviewees stated that the consumer would not be willing to pay more for innovative sustainable packaging.



Figure 3.2: Marketing and economic

The vertical axis deals more with economic aspects related to the development of innovative sustainable packaging. Actually, the word cloud of Figure 3.2 reveals a high frequency of the word 'expensive', 'cheaper', 'economic' and 'benefit'. Thus,

stakeholders perceive that consumers prefer an affordable product that is worth-the-money. The production of sustainable packaging must balance between aspects of economic and resources optimisation, and some interviewees commented on the difficulty of achieving this objective. An interviewee stated that shift of traditional materials into more sustainable would not be economical for some food companies such as small-scale business or local business. The word 'modification' of packaging was linked to the difficulties of small-scale packaging business to develop innovative solutions because the increase in their annual cost would push them out from the industry.

Moreover, another issue on economic and environmental inter-linked highlighted during the interview was the product would probably degrade from its original packaging if changed to the sustainable packaging material. For example, if food product that supposed to pack in plastic packaging has been changed into paper-based packaging probably shorten the usual shelf-life from previous. This response of the interviewee was related to the issues of sustainable packaging as written in the previous chapter. The selection of packaging material should be compatible with the food items; so, it can reduce the environmental burden of food waste and its packaging, simultaneously (Lindh, Olsson & Williams, 2016). On the other hand, positive economic aspects were linked to the 'reduction' of packaging resources because they will 'minimise' the production cost. Interestingly, interviewees were also prone to recyclability material because of the possibility of generating extra revenue. Particularly, this will benefit more to waste management companies as the recycling process produces methane gas that can be converted into electricity, and the recycled output could be sold to produce secondary packaging.

3.2.4.2 The packaging policy theme

The packaging policy is another important theme because the food production system requires to comply with rules and legislation in place. Figure 3.3 illustrates that 'recycling' is the most recurrent word policy of this theme. This is because food producers and retailers have to comply with the UK policy on recyclable certification packaging and also the EU Directive on reducing packaging waste to improve environmental conditions, i.e. 'waste' reduction to landfill and illegal littering on the streets. One of the interviewees strongly emphasised that every stakeholder involved with packaging must oblige any legal food rules and regulations from the legal authority as well as his own business packaging prerequisite. This includes appropriate packaging material and adequate information displays on the label. Moreover,

certification confirms that packaging waste can be treated in the correct manner in the reprocessing centre, such as PRN note system. In fact, the recycling scheme for post-consumer in the UK is directly clarified with ‘information’ for usage. For instance, a participant said that UK most common recycle scheme called ‘on-pack recycling label’ (OPRL) is one of the most successful systems to enhance recycling culture among food producers, retailers and consumers simultaneously.



Figure 3.3: Packaging policy

Most of the interviewees also consistently mentioned the importance of resources ‘management’ for their sustainable packaging (Figure 3.3). A code called ‘resources competency’ encompassed the responsibility and recovery plan of industry businesses. Some interviewees expressed the belief that recyclability guarantees material health and ‘maximise’ the usage of packaging material until at ‘disposal’ stage. Moreover, the traceable source of the material like ‘forest stewardship’ certification can be perceived as a strategy to sustain natural resources.

While for the previous theme interviewees were concerned about the costs of innovation for small-scale firms, in this case, they were worried about waste management facilities. For instance, interviewees spotted that previous invention of degradable plastic packaging causes the problem to waste stream. This is because no clear ‘disposal’ route for that degradable packaging as that word disposal appears significantly amount in the cloud (below word ‘recycling’). There is no specific waste bin to dispose of the degradable bag, and in the end, degradable packaging treated as ‘unrecyclable’ and channel to ‘landfill’ or ‘incinerate’. Moreover, there is also a matter

innovation in packaging is to protect the product longer and avoid difficulties for the consumer that can impact negatively on their businesses. For example, with the use of double-packaging of the food product could be consumed longer than one layer of packaging. Owing to that fact, interviewees also stressed out that additional 'convenience' function on the packaging is relatively crucial because the price factor seems less significant when consumer willing to trade-off for their advantages (Jinkarn & Suwannaporn, 2015). For example, extended 'shelf life' probably would decrease consumers' loss for groceries shopping and save money for other household products.

As mentioned previously, consumer perception is often overlooked in sustainable packaging design. In a real market situation, even though consumers pay attention to the sustainability attributes of product packaging, most of them are attracted to the physical attributes of the packaging. Thus, food producers are putting initiatives on the physical appearance of that packaging more than other aspects. The visual appearance of food packaging is the first thing consumer see on the shelf in the market. For the food producers and retailers, 'attractively' and 'flexible' were interactive words to communicate with their consumer about their product benefits. An interview reported that 'pouch' design become a trend in most consumer good product such as coffee, sweet and dried fruit. It requires less material, light, saves spaces in kitchen shelf and reduces production cost as well. Similarly, an interviewee from major retailer stated that added values like Braille, re-closable, vacuum pack and seasonal design (e.g. Halloween), also give pleasure for consumer consumption, undoubtedly. For them, these sustainable attributes from the social aspects keep the food fresh, last longer and eye appealing. Moreover, they able to capture more consumer segments in the real market too. Regarding packaging shape, the conventional design of food packaging like cartons, box, tray, can, jar and pod were still commonly seen in the sustainable packaging market.

With regard to the packaging material, a variety of 'fossil' fuel-based plastic such as polyethylene and high-density polyethylene are widely used in the food industry. Besides being suitable for recycling, the light and flexible characteristics of this plastic have been used for many years in the food packaging industry. However, Figure 3.4 also shows the importance of 'plant' based plastic word emerged on the upper left side of the cloud. This plastic claims to be compostable or naturally biodegradable, which can disintegrate at home or compost facilities (Othman, 2014). However, some interviewees argued that the supply of fossil plastic is more stable than controversial plant plastic. Besides plastic, 'glass' is also be used as sustainable packaging because the recyclability of that material is more certain than plastic.

Lastly, findings suggested that another tangible packaging design for the consumer is the visual recognition of sustainability. It is almost impossible for the consumer to know the sustainable quality of the packaging, except if the quality showed as in an official logo or an information display on the label (Lindh et al., 2016). The words like 'information', 'OPRL' (next to word 'life') and 'Forest Stewardship Council (FSC)' (below word 'information') schemes were appearing at significance frequency in the cloud (Figure 3.4). For example, the OPRL scheme notifies consumers the proper discarding method with a symbol called "widely recycle" or "check locally" or "currently not recycle". However, some interviewees responded that it was unnecessary to display the certified sustainability label because the consumer does not pay attention to this type of certification. Interviewees also stated that consumers sometimes felt confused by the meaning of the labels. For example, an interviewee complained about the consumer's misperception of the carbon footprint label because she does not know whether this is for the food item, the packaging or both. This consumers' misunderstanding is another important aspect to take into account in the development of innovative sustainable packaging. Another interesting point of disclosure was the word 'recipes'. Interviewee exposed that the recipe suggestion on the label has the ability to reduce food waste because it somehow hints an idea on how to well-used the product entirely.

3.2.5 Conclusions of in-depth interviews

As well as regulations of food packaging, results of in-depth interviews suggest that when designing innovative sustainable food packaging businesses should take into account the following four important elements: consumer's functional attributes, recovery plan of packaging material, packaging shape and sustainable labels. The main purpose of the packaging is to deliver food and drink items safely and in good quality to gain consumer's trust and loyalty. For the industry, consumer's preferences and feedbacks are essential as there is an obvious connection between packaging and their consumption trends. The food producers and manufacturers are always trying to provide a stress-free and convenient product to their consumers. Therefore, the consumer's recognition determines usually shaped the formation of sustainability designs in the packaging industry and the effectiveness of sustainable practices altogether.

In relation to consumers, the food industry is still upgrading the physical and visual sustainability features of their packaging. From these results, traditional and conventional packaging materials such as glass, fossil-fuel plastic, paper and metal are

continuously trending material of food and drink products in the market. The industry is endlessly improving the conventional materials to more environmental-friendly and also the material that can provide benefits to the consumers as well. This includes proving sustainable entitlements on the packaging label. Previously, producers' sustainable claims were related to the food content only, such as organic food certification and GMO-free certification of the product. However, since consumer shifted to sustainable lifestyles, the sustainable entitlements of packaging are essential aspects for the food producers, recently — many organisations such as WRAP in the UK accountable to issue a recyclable certification of any food product such as OPRL scheme. Such labels give assurance to the producers and consumers that they are doing something good for the environment.

Moreover, the packaging shape is also an important aspect of the sustainable packaging. Results revealed that conservative shapes such as can, carton, bottle and tray are the most commonly used for food and drink products in the UK. These forms are not only familiar to the consumers, but also help producers to reduce production and transportation costs. A new shape of packaging may require an extra budget to the businesses, and it might be unacceptable to the market. The pouch is one new invention made by retailers to pack dry products such as nuts, coffee and dried fruit. However, pouches for milk are unreliable as packaging for consumers, and they were drawn out from the market years ago. It concluded that a new packaging shape might be appropriate to a certain group of food items only and it could not be suitable for others.

Lastly, a recovery plan is part of the Packaging and Packaging Waste policy of EU Directive. The Directive encourages producers and retailers to be responsible for all products manufactured from the beginning until the waste in order to get packaging in good conditions to be used for other purposes. The recycle and recovery plan should always be an important aspect when creating innovative food packaging. Most of the interviewees mentioned recyclable material as it is the one that widely uses in the UK and the availability of the recycle facilities worldwide. Instead of that, they are trying to find more sustainable resources for packaging materials such as bio-based plastics. Even though the bio-based plastic is becoming controversial issues among the producers, it is still ongoing research to improve the quality of any potential packaging material in the industry. Despite all the elements elaborated above, consumers are the main determinant of any innovation of sustainable packaging, and thus, it is better to understand their sustainable packaging needs. These interview inputs will assist the focus group discussion in the next research method.

3.3 Focus groups

Focus group is a qualitative research inquiry technique that collects data from the interaction of homogeneous people in a focused discussion. The application of this method is helpful in assessing needs, generating information for constructing questionnaires as well as discovering how consumers make decisions to use or not to use a particular product or service (Krueger & Casey, 2015). During the discussion, the interaction among participants explain or clarify their behaviour on a particular topic of interest and thus focus groups produce more in-depth information on the topic in comparison to surveys (Patton, 2002). Unlike surveys, qualitative methods allow an individual to respond in their own words to express their personal categorisations and perceived association; however, they are not completely unstructured (Stewart & Shamdasani, 2015). Focus groups are interesting because they allow both researchers to explore deeply on a topic and participants to express their perceptions using their own words (Debus, 2007). For these reasons, the focus group technique is well-suited to this study because it allowed the researcher to explore and examine important sustainable innovations of food packaging and to get insights on how consumers react to eco-friendly packaging.

3.3.1 Development of the focus group protocol and guidelines

First and foremost, a predefined focus group discussion protocol was prepared to guarantee a smooth discussion, and that all essential questions were asked in a conversational manner. The protocol provided guidelines and dialogues that researchers could use during the discussion session, i.e. interview questions and cards to illustrate problems and facilitate dialogues. In general, several types of questions were asked, such as introductory questions and key questions where every question was allowing for different time allocation according to importance, as shown in Appendix 7 and 8. The discussion started with an introduction that provided participants with generic information such as the discussion being audio recorded, ensuring them about anonymity, the objective of the study and that answers were subjective and could be varied from each other. Ice-breaking questions were asked at the beginning of the discussion to create a relaxed atmosphere and overcome shyness among participants; socio-demographic characteristics of the participant were also collected at this time.

The focus group discussion was divided into two main parts. The first part included questions that seek the knowledge and attitudes of the participants as well as their

understanding of the current environmental situation of food packaging. The discussion of sustainable packaging was triggered by asking the participants to discuss sustainability and few environmental situations that came to mind when thinking about current food packaging and solid waste. Moreover, they had to evaluate the differences between bad and good packaging from their point of views in order to allow researchers to gain an understanding of what participants perceived and conceived of food packaging in the UK. Specific experiences or examples with food packaging were also elicited to determine their impressions towards mentioned packages. The first part also aimed at collecting participants' awareness of current packaging waste problem and their personal obligations towards it. At the same time, a summary of the WRAP survey on the food packaging waste problem in the UK was presented to the participants to help them understand the situation better (Card 1 in Appendix 8). Then, a set of questions on participants' attitudes on food packaging waste situation were asked to describe the scenario of current food packaging available in their surroundings. The first section ended with the introduction of sustainable packaging that should be available in the market to lessen the environmental impact of the accumulation of food packaging waste.

In the second part of the discussion, a set of alternatives innovations or attributes of sustainable packaging to be included in the questionnaire were presented as visual cards. Milk was chosen as the commodity of these innovative sustainable packaging solutions that participants had to evaluate during focus group discussions for the following reasons:





- Milk is consumed almost daily in every household, and its production is increasing yearly according to Agriculture and Horticulture Development Board, and until May 2017, DEFRA recorded that 1,328m litres of milk deliveries made per day for the entire UK.
- Milk is considered to be healthy food that helps to avoid bone diseases and cancer, such as osteoporosis and colorectal cancer (FAO, 2013). Thus, with this perspective in mind, it is crucial that milk producers consider the positive image of milk packaging from an environmental perspective — the packaging that sustains the environment as well as brings benefits to the consumers.
- Consumers seem to be more aware that the evolution of milk packaging from glass-bottled to plastic packaging has a negative impact on the environment. They also perceive that the traditional packaging of milk can assist in reducing waste (Neill & Williams, 2016). Furthermore, milk is a product that can be

packaged by innovative and different sustainable materials that are cheaper and bring no harm to the environment (Ghenai, 2012). The terms 'recyclable' and 'bio-degradable' became known to consumers that will reduce the waste problem and sustain the ecosystem. As a result, milk packaging that gives no impact to the environment will add further benefits to the consumption of dairy milk.

For these reasons, the second section of the focus group protocol explores participants' views on various aspects of sustainable packaging referred to 1 litre of dairy milk. Eight cards were developed (see Appendix 8) to show participants information regarding the sustainable packaging and current packaging situations in the UK and to trigger discussion and elicit preferences about different innovations. Card one presented selected results of the WRAP 2013 survey in relation to environmental problems created by packaging (WRAP, 2013a). Card two showed a selection of milk packaging materials used in the UK. Card three illustrated the five different environmental packaging materials (reusable, compostable, recyclable, biodegradable and degradable) obtained from in-depth interviews, while card four the packaging style (can, pouch, carton/box, and bottle/jar). Card five collected information about expectations on the milk quality with eco-friendly packaging, while card six gathered preferences of packaging functions (re-closable/resalable, openability, easy to dispose, gripability) used to protect, communicate and bring convenience to consumers (Lindh et al., 2016; Magnier & Schoormans, 2017). Card seven instead offered participants the possibility to discuss different types of labels that might be familiar to them and could be used on innovative sustainable packaging. Last but not least, card eight explored participants' willingness to pay (WTP) for eco-friendly packaging. WTP was elicited showing a payment card where monetary values ranged from £ 0 to £0.30. Figure 3.5 presents some of the cards, as mentioned. The focus group research protocol was piloted with students in May 2017.

Card 2

Please read at these packaging carefully and rank them from 1 to 9, assign into the most sustainable and the least sustainable to you in the box given

		
Glass bottle <input type="checkbox"/>	On-the-go carton with straw <input type="checkbox"/>	Transparent plastic container <input type="checkbox"/>
		
White plastic bottle <input type="checkbox"/>	Carton with cap <input type="checkbox"/>	Carton without cap <input type="checkbox"/>
		
White plastic pouch <input type="checkbox"/>	Transparent plastic bottle <input type="checkbox"/>	On-the-go pouch <input type="checkbox"/>

Card 3

Please read carefully of these 5 environmental options of packaging material. Then, rank them from the most and less preferable to you for 1 L of milk.

- Recyclable**

Material design to collect and reprocess to produce another item. It can be litter in any available recycle bin.
Types of material: Paper; Metal; Glass; Bioplastic (plastic made from agricultural waste like wood pulp, corn, soy or sugar cane); Recyclable plastic.
- Degradable**

Material design to breakdown into small particles after chemical reaction with oxygen, light or heat after disposal. It is made from wood pulp and plastic. It is also likely to survive long enough for deteriorate.
Types of material: Regular plastic (weakened structure or chemical additive); paper
- Compostable**

Material design to breakdown into carbon dioxide, water and compost. It produces no trace and no toxin, but producing a nutrient-rich soil. It is made from wood pulp and plant-plastic. For plant-plastic, it can be decomposed at home or industrial facility; but takes 90 – 180 days to breakdown.
Types of material: Paper; Bioplastic
- Bio-degradable**

Material design to breakdown into carbon dioxide, water and methane gas from action of naturally-occurred microorganism likes bacteria. It is made from fuel-based plastic or plant-plastic where can only be decomposed in special facility.
Types of material: Bioplastic (plastic from plant); paper
- Reusable**

Material design for repeated usage more than one times as the same packaging commercially. It has attributes such as durability, ease of cleaning or provide inexpensive return when empty
Types of material: Glass

Card 6

Packaging function is the ability of the package to protect, communicate and bring convenience to consumer. Here are 6 packaging functions, please read carefully and rank them from 1 to 6, as 1 is your favourite to 6 is your least favourite function for innovation of milk packaging?

- Easy to dispose**
 - Package that is easy to sort into waste bin after use. It includes easy to rinse, fold and avoid confusion on how to dispose
- Gripability**
 - Ability to grip the package determined by size, shape, handle, material stiffness and packaging surface
- Second use**
 - Package that developed with second use in mind after use the product inside
- Integrated use**
 - Package that able to use as serving (tray), preparing or consuming the product directly in the package to optimise the utilisation
- Openability**
 - Ability to open with or without tools for all groups of consumer
- Re-closable/ Re-sealable**
 - Features that keeping the package tight and maintaining product quality after it has been opened.

Card 7

This is an example of a label on a food packaging. Please look at it carefully, which of these labels/phrases on any food packaging are FAMILIAR to you?



- (1) Personalised sustainable information
- (2) Official accreditation of material
- (3) Certified scheme to dispose packaging
- (4) Certified scheme to inform the involvement made by buying this product
- (5) Association with environmental organisation
- (6) Environment-related colour

Figure 3.5: Examples of focus group cards

3.3.2 Sampling, recruitment procedure and preparations of focus group

3.3.2.1 Sample size

The rule of thumb to determine the size of a focus group is to select from ten to twelve participants for each group and develop themes or codes until the researcher achieves a saturation point. A saturation point is when all the range of ideas have been discussed and heard, and there is no additional information arising during the discussion (Krueger & Casey, 2015). This study was conducted with focus group composed from six to eight participants because a smaller group is favourable to give everyone a chance to share insights and opinions (Krueger & Casey, 2015). However, when the group exceeds more than eight people, the discussion is still devoted as acceptable and can be conducted as planned. The criteria of the sample size of a focus group are not so important as the ability of the discussion to generate meaningful information (Patton, 2002).

When choosing participants, homogeneity is the guiding principle, and their selection is based on several criteria including similar socio-demographic characteristics, knowledge of the topic and whether they would have some things to say on that topic (Krueger & Casey, 2002). In this study, homogeneity included age, British citizenship and responsibility for grocery activities were the main criteria for the participants to be selected. These criteria allowed researchers the possibility to explore and obtain an understanding of sustainable packaging from a consumer perspective in the UK. For this study, a pilot group and six focus groups were run interviewing from six to nine participants in each focus group. The pilot focus group was conducted with five final-year British undergraduate students in order to explore their experiences and views towards packaging and sustainability in the UK. This piloting was important to guide and test the protocol and flow of the discussions before running the other six focus groups.

Snowball sampling and flyers advertisements posted on social media and public bulletin boards were used to recruit focus group participants. Snowball sampling was done by asking the participants who had already participated in one of the focus groups to pass the information to potential participants belonging to similar categories (Krueger & Casey, 2015). This recruitment strategy is generally used by marketing agencies to gain feedback on the product they want to introduce on the market and can be effective in certain situations in order gain sufficient variation of participants (Liamputtong, 2011). Flyers contained information about the study purpose, criteria for

voluntary participation in the study, contact details of the researchers and reimbursement for the participation in the focus group discussion. The flyers were placed in several businesses and government establishments around Reading (Berkshire). With permission of the establishments, the flyers (see Appendix 6) were posted on bulletin boards in public libraries (Wokingham, Central Library, Caversham, Whitley, Tilehurst, Battle and Southcote), town halls, several community centres, grocery stores, shopping malls, job centres, civil offices, society clubs, restaurants and pubs, churches and bus stops. Moreover, the electronic version of the flyer was also posted on social media, circulated via emails, and word-of-mouth to in order to attract enough participants for the screening process.

3.3.2.2 Recruitment process and preparations of focus group discussions

The recruitment process began after the endorsement of ethical clearance from the School of Agriculture, Policy, and Development University of Reading (see Appendix 5). The application of the ethical was submitted in April 2017 and included the focus group research protocol, flyer, consent form, demographic questionnaire as well as cards and participant information sheet. The recruitment began after the approval of the ethics committee, as mentioned in the above section. Potential voluntary participants were contacted via emails and telephone calls and had to answer some filter questions to understand whether they could be included in one of the six focus group discussions. In particular, they had to provide information about their age range, educational level and citizenship (see Appendix 9). Furthermore, the screening process also explored participants' availability in order to allocate them across the six focus groups.

Eligible participants were grouped in one of the six focus groups to ensure the background variation of the participants. One week prior the running of each focus group, an email of confirmation was sent out to the selected participants providing them information about how to reach the venue at the University of Reading, about the study, confidentiality (see Appendix 9) and reward of £30 for the participation in the study. The pilot focus group was conducted in April with local students, and after revisions and few modifications, the six focus groups were carried out from May to the end of July 2017. Generally, all focus groups began at 4 pm and lasted approximately two hours. The discussions were audiotaped with the permission of the participants, and the session started with an explanation of consent details, confidentiality issues and the guidelines of the discussion. After participants signed the consent form, they were required to complete the demographic questions, and the discussion commenced

with the self-introduction of all participants. In the meantime, refreshments, such as juices, water, soft drink, biscuits, and chips were offered to co-create with respondents an atmosphere where everyone could feel relaxed, less self-conscious and comfortable to form relationships with each other and the moderator. The researcher acted as the moderator for all focus groups and an assistant, who did not participate in the discussion, was responsible for recording.

3.3.3 Data analysis

Analysis of data collected with focus groups required the preparation of raw data (transcriptions), data coding and determination of themes. Even though the literature on the analysis of qualitative data provides strategies based on suggestions and theoretical aspects (Bazeley, 2013), the analysis of qualitative data is unique according to the specificity of the study and its objectives. However, any strategy of qualitative data analysis must involve reduction of the data to a manageable size in order to allow identification of the fundamental themes relating to the objective and topic, in this study sustainability and food packaging (Bazeley & Jackson, 2014). Raw data in the form of audiotaped interviews were transformed into written transcripts and entered in the NVIVO version 11, while data from handwritten cards were filled in the SPSS version 24 for further analysis. In total, 540 minutes of interview tapes, 330 pages of transcripts and 322 cards collected from 46 participants of the focus groups were analysed. An example of the transcriptions can be found in Appendix 10, and Table 3.3 below shows the socio-demographic and economic characteristics of focus group participants.

Table 3.3: Socio-demographic and economic characteristics of participants

Demographic	Frequency	Percentage (%)
Gender		
Male	21	45.7
Female	25	54.3
Age		
Younger than 25 years	18	39.1
From 25 to 44 years	12	26.1
From 45 to 64 years	12	26.1
Older than 64 years	4	8.7
Education		
High school / tertiary	16	34.8
Degree / postgraduate	30	65.2
Income per year		
Less than £20,000	15	32.6
From £20,000 to £39,999	13	28.3
From £40,000 to £59,999	15	32.6
More than £59,999	3	6.5

3.3.3.1 Data coding and construction of codes

Data saturation and the participants' composition were the two principles used to determine the sample size. These requirements were necessary and useful to understand participants' attitudes towards environmental issues that can affect consumers' choice of innovative sustainable packaging. Progress towards the end of focus group discussions showed that data collection was good enough and representative of all six groups. Almost every important aspect was covered, and the data generated was considered sufficient to provide an insightful understanding of the problem and eco-friendly sustainable packaging.

Data analysis began after each focus group by working through the transcripts and listening to the tapes to get the views of the topic in general. Then, the interviewees' responses were grouped into various categories corresponding to the questions or parts of the discussions. The transcripts with grouped responses were reviewed again and electronically highlighted according to patterns developed in NVIVO. The highlighted participants' responses were cut out and arranged into piles of quotes with similar information, named, and used as generation of initial codes of focus group data. For example, when a participant stated, '*sustainability is to keep things going for future*' and another participant stated that '*sustainability is to think of the environment and the future of younger generation*', these two responses were grouped and piled together in one codenamed 'Definition of Sustainability'. This process was applied to the transcripts of all six focus groups.

Initial codes were repetitively observed, visualised, and reviewed in order to be sure that every response of participants was relevantly sorted in the same group of initial codes. As a result, 106 initial codes were reduced to 66 codes and finally to 19 child themes, which were then divided into the following five parent themes that will be explained shortly in the next subsection. This process was done by observing similarities between initial codes and identifying the association of one code with others identified with data analysis. In the final part of the analysis, child themes and parent themes were named on the basis of the literature and contextual situation of participant's responses (Bazeley, 2013; Saldana, 2016). These codes were then prepared for the data visualisation and further analysis such as matrix coding between participants' demographic and their responses, word frequency and text analysis to discover patterns and explain results.

This process had the objective both to explore participants' perception and experience of food packaging and sustainability in relation to their socio-demographic characteristics and to produce a matrix coding test and word frequency analysis guided by the literature. The matrix coding test is an analysis that compares the responses of child themes with the demographic profiles of the participant. For example, the 'protecting ecosystem' theme was explored looking at differences between male and female participants, while the word frequency analysis was performed to identify the most frequent words that had been spoken during the discussion to confirm the robustness of results.

3.3.3.2 Identification of sustainable packaging innovations

As reported previously at the beginning of the analysis section, information related to the alternative innovations of sustainable packaging was inserted into SPSS version 24. The cards were ranked by the participants during the discussion and collected at the end of each session. Participants were given opportunities to explain their reasons for the ranking, even though some of them only agreed with what was said by the fellow group members. Participants' ranking of innovations and willingness-to-pay cards were analysed by demographic profile of the participants. The purpose of this analysis was to get insights about most preferred innovations, the average amount of willing to pay and to identify attributes that consumers might prefer when buying eco-sustainable packaging. Thus, with their choices of innovation alternatives were supported by the reasons stated in the first section of the discussion, the comparison analysis will offer the desired sustainable packaging of each consumer groups in the UK.

3.3.4 Focus group results

The analysis is divided into two main parts. The first section consists of the child thematic codes, which led to final parent themes generated from the data, as shown in Figure 3.6. The following five main themes were identified: personal comprehension of sustainability, perception of current food packaging, preferences of eco-friendly packaging, perceived responsibility of authorities and food producers and eco-labelling issues and policy implications. The main purpose of this part was to identify and describe the hypothetical ideal packaging attributes chosen by the consumers during the first part. The results were generated from the analysis of word frequency, matrix coding (see Appendix 14) and literature-based analyses and they are discussed hereafter. Salient aspects of the discussion will be reported in *italic*. The second part

explored participants' preferences towards innovative sustainable packaging attributes of dairy milk.

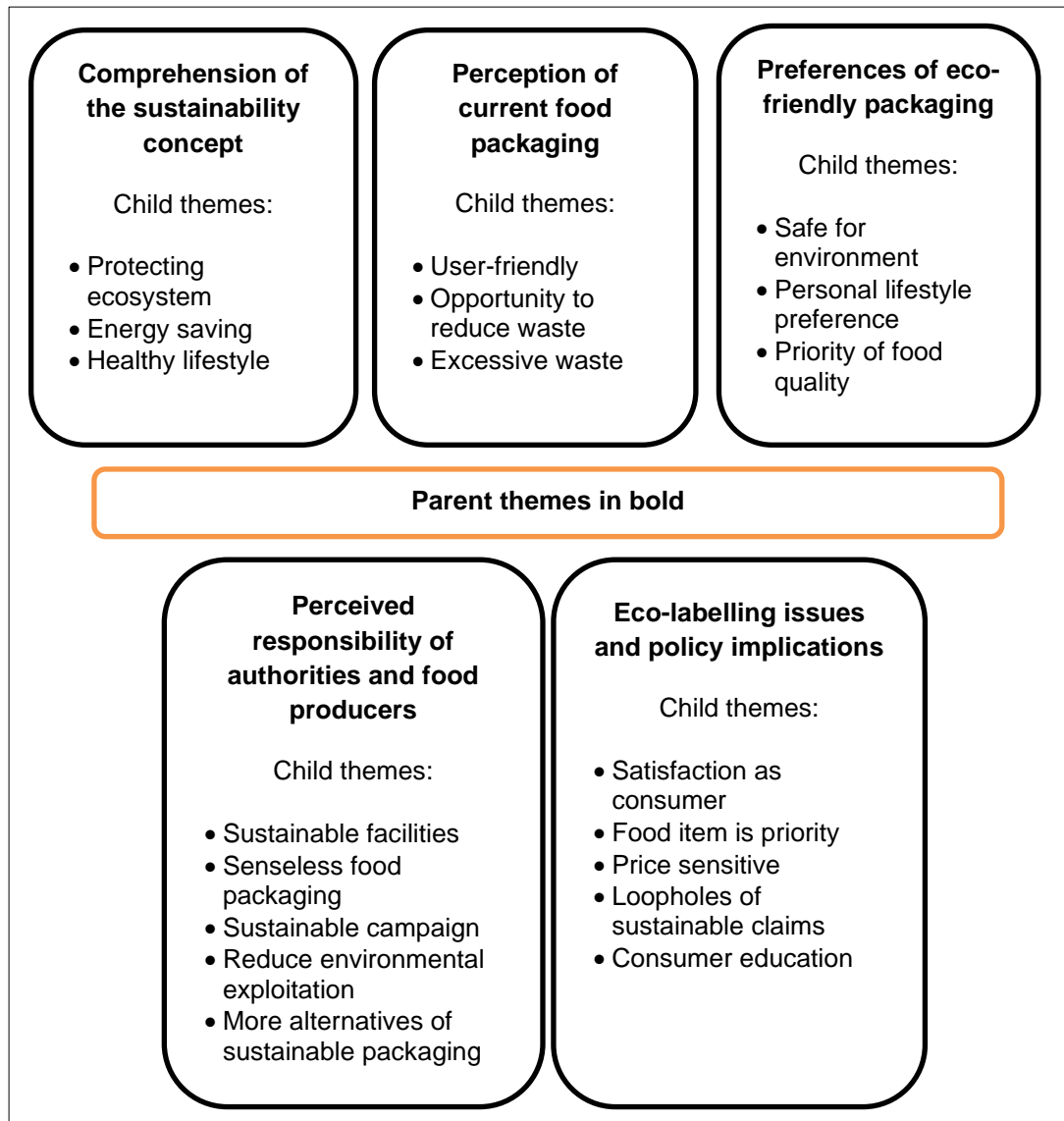

Figure 3.6: Parent and child themes emerging from focus group discussions

3.3.4.1 Comprehension of the sustainability concept

Results reveal three significant elements of sustainability that participants tended to deliberate during the discussions. In their minds, sustainability is protecting the ecosystem, saving energy and living a healthy lifestyle. All the participants agreed that the protection and preservation of the natural environment is the primary concern of sustainability. For them preserving the ecosystem will eventually reduce the chances of losing biodiversity and protect natural resources such as crude oil and food sources.

I think it is something that you can keep for a long time — something that you can maintain for quite a while, so it does not just decompose all the sudden (Female, 21 years old).

Sustainable food sources are something that is not going to run out (Male, 21 years old).

Participants were also aware of the decreasing quality of the environment as mentioned in many environmental and waste studies (Andrady & Neal, 2009; Berto et al., 2017; Magnier & Schoormans, 2015). Participants showed concerns about climate health and explained environmental problems such as loss of biodiversity and poor solid waste management by lack of responsibility on behalf of the consumer and the authority. Problems created by the throwaway culture and reckless waste management were considered detrimental to the loss of wildlife and environmental damage.

There a lot of problems (referring to the pollution), numbers of the animal dying, and coral reefs got bleached (Female, 30 years old).

There is loads of plastic in the ocean which is having a detrimental effect on wildlife in the ocean (Female, 21 years old).

Where they go to put all it all? Built a new landfill site, is it? (Male, 65 years old).

Another element of sustainability identified by participants was energy saving. In agreement with previous literature, sustainable development has to find a way to save the resources by using renewable natural resources and lessening the current ecological problems (Magnier & Crie, 2015; Okuda & Thomson, 2007). Participants agreed that finding alternative and safe resources, yet cost-effective is an effective way to sustain the environment. At the same time, the food producers should take action to reduce the amount of waste in their products and minimise the use of non-renewable resources.

Using products from the environment that are naturally reproduced in the environment (Male, 64 years old).

I hate when the fruit comes in a bag, like bananas in a plastic bag. Bananas have their own packaging. It is a waste of resources and ridiculous (Male, 65 years old).

Participants also believed that consumers are important actors of the sustainability challenge. Some environmental problems are coming from unsustainable consumer purchasing behaviour, ignorance and negligence towards disposal of their products.

You get people that buy plastic, packs a bottle of coke and throw it in the sea or the river. Some people do not care; some people do not know. You need to take ownership of your own environment and not just assume it is somebody else problem (Male, 65 years old).

Perceived from consumer's preference in the past, they (seller) like to have straight cucumber instead of slightly curved cucumber on the shelves (Male, 64 years old)

Nobody is going to buy the whole bag of potato if one of it is mouldy (Female, 45 years old)

However, some participants also highlighted that the definition of sustainability affects their lifestyles. They emphasised the importance of increasing the consumption of local food because of the reduced negative impact on the environment. This aspect is confirmed in past studies where it was found that the consumption of local food has increased in the UK, US, Finland and Japan because of the perceived better quality and reduced costs (Brunori & Galli, 2016; Lehtinen, 2012).

We have to be very careful how we dispose of the packages and other stuff, to protect the environment. I do follow the rules (Female, 37 years old).

Aiming to have zero carbon and zero waste (Female, 30 years old)

I have been eating berries from the garden on a daily basis, a handful every day. I find that much more refreshing than going to the supermarket and picking up a package (Male, 50 years old)

3.3.4.2 Perception of current food packaging

With regard to the perception of current food packaging available in the market, participants stated both positive and negative comments. For example, positive comments were expressed in relation to saving, convenience and reduced waste. The elderly stated that some of the current packaging are helping them to reduce their daily expenditure. Meanwhile, younger participants believed that smaller or individual

pack is a good initiative on behalf of food producers because it helps to cut costs and reduce the amount of packaging used.

I do not think the packaging is excessive. A few years ago, it was in a bigger box and then now they (food producers) have cut back on costs. I think they wanted smaller or less packaging cost (Male, 34 years old).

There is such interest in the resealable packs for things like cheese, bacon and meat (Male, 60 years old).

Moreover, current packaging has more options to improve the opportunity to reduce waste, such as a food product available in different styles of packaging materials. This aspect was received more as a challenge for participants because of the cognitive effort to choose wisely and react to their sustainability values. One participant mentioned that the market offers loose products instead of packaging such as food that has its own natural packaging, while other participants also said that producers are slowly changing their product packaging to simpler and less complicated.

Some of the supermarkets have done, what they called cheaper brands: brands that have no thrills but just plain packaging which in its own way and does not stand out from everything else (Male, 60 years old).

I was going to say onion. Onions have natural skin (Female, 30 years old).

We are making steps in the right direction. When you look at Easter Eggs over the years, they are slowly cut out the unnecessary stuff (Male, 21 years old).

However, most of the participants in all focus group shared opinions of the excessive waste generated by the current food packaging. They agreed that packaging is overly-designed and increase the solid waste accumulation into the environment. Furthermore, the discussion revealed similar arguments with the extreme used of plastic in the food product. Overall, plastic was seen as 'bad for the environment' and made from non-sustainable resources. They expressed interest in putting food and drink items into other types of packaging such as glass or paper due to the recyclability and chances to reuse it again in the future.

When I go to a supermarket, my children start looking for a thing that is nice, well-designed and attractive, pick it up quickly. And then if I look inside it, it is just

rubbish. They definitely fooled for the beauty of the packaging and not the content (Female, 37 years old).

Like Christmas crackers, Happy Meal boxes and Kinder eggs which are just plastic (Female, 30 years old).

We are also not using a sustainable source to recreate the plastic in the first place (Male, 24 years old).

I imagine the waste made from the lids alone (Female, 21 years old).

As regards waste accumulation, plastic was considered the main contribution to the problem. They highlighted the issue of the 'plastic island' on the ocean and drained blockage that had caused much damage to the environment. Plastic packaging was generally perceived negative, and thus this indicates that consumers are aware of the consequences of plastic, even though some of them did emphasise the advantages of using plastic as packaging due to lightweight and its flexible use.

3.3.4.3 Preferences for eco-friendly packaging

Almost all participants showed a preference for eco-friendly packaging because of reduced negative impact on the environment. This finding corroborates several studies that highlight environmental-friendly goods are of interest to all societies and that consumers are conscious about this problem when shopping for household products (Bickerstaffe, 2000; Jerzyk, 2016; Magnier & Crie, 2015). Participants also started to rethink about their previous behaviour and how to make changes in terms of shape, material and function of packaging when making their food choices. They stated that eco-friendly packaging should have the potential to be reused like a coffee jar, clear information on disposal and use the minimum amount of packaging.

Quite good if you could re-use it in some other way in the house, like coffee jars, glass. I'm still using them which I had in the 1960s. They are useful (Female, 81 years old).

The minimum amount of packaging ideally is the best (Male, 55 years old).

I'd do my best to dispose of all my packaging in the best way I can (Female, 38 years old).

I try and look at the little recycling symbol (Male, 22 years old).

Although positive attitudes towards eco-friendly packaging were displayed on how to select food or drink products daily, personal food preferences took priority in their choices. Even the most environmentally friendly consumer does not choose any food product merely on the basis of the environmental aspects, but rather on the trade-off between personal desires and eco-friendly attributes (Rokka & Uusitalo, 2008). Food protection, convenience, value for money and special nutrition needs were all attributes that were considered more important than eco-friendly packaging.

I avoid buying glass products because I do not have a recycling facility at home. So, I have to walk a great distance with all my clunky glass to dispose of. So, it put me off (Female, 35 years old).

I definitely will not like to have milk in a glass bottle because I got children and it could break and cut someone in my house (Female, 37 years old).

I've made a shift to lactose-free milk, first of all. I do not understand why they cannot do it in the UK (carton with no lid). Because whenever you recycle a carton with the plastic lid, you need to take the lid off. But I personally, I do try to do it when I can. But if I can buy something that's more sustainable, then I will (Female, 23 years old).

Sometimes you don't have a choice because a lot of stuff is in plastic, and what do you do? You need to buy the products (Male, 64 years old).

I moved into a house that has very odd shaped cabinets which means that certain boxes of cereal cannot stand up in it. I have to think about it a lot it now when I go shopping (Male, 31 years old).

I do not want to see my vegetables not wrapped. The supermarket is not clean enough. Germs are flying in the air. I want it covered (Female, 37 years old).

Moreover, most of the younger participants were interested in packaging ease to dispose due to their work commitments. The packaging that uses only one type of packaging material such as can foods can be disposed without thinking too much on where they should put the cap, the label and body of the packaging. Meanwhile, older participants preferred to choose a loose product for vegetables, even though they

showed supports towards eco-friendly packaging. Even more, they liked the idea of the second use of the packaging after they finished use the content such as the coffee jar or hard plastic container.

Solid lumps of polystyrene, I reuse those in the garden where I put in the bottom of the pot. They will stop you losing quite much compost and make it easier to lift it (Female, 40 years old).

I take my own bags, and the best fruit and vegetables are the ones that come straight from the farms itself (Male, 50 years old).

I live alone and prefer to limit food wastage (Female, 35 years old).

3.3.4.4 Perceived responsibility of authorities and food producers

Responsibilities of the local authority and food producers were mostly mentioned as an issue of the environmental problem when talking freely about the packaging waste problem and food or drink products on the market. Participants' concern was generally about sustainable facilities available in the neighbourhood and pointless food product on the market. Many of them agreed that recycling facilities for some packaging were unavailable in the neighbourhood and thus they had to walk or travel long distances to dispose these materials. Moreover, they found that some food packaging had layers without a clear purpose, even though they believed this might be explained by the fact that this type of packaging satisfies the needs of some consumers.

My local council does not recycle plastic bottles, so I have to go out of my area with my bike since I do not have a car (Female, 38 years old).

If you buy a cucumber, it is wrapped with plastic and put it inside another plastic. No need for it, but some people might prefer it (Male, 34 years old).

Participants had a clear view that they as consumers accounted for the pointless packaging design and packaging waste, but also that they have the ability to lessen the impact of this unsustainable purchasing behaviour. However, authorities and food producers were responsible more than consumers for the packaging they created. For them, 'companies' as food producers, should be accountable to the waste problem created by their packaging because they make the product only if they can increase their profit.

I think with food companies, the majority of them probably won't consider unless it makes a difference to their profit margins in some way. In one way, it is the consumer's responsibility to highlight issues, like about coffee cups, which I had no idea about until they highlighted that you could not recycle a coffee cup (Male, 31 years old).

Sustainable development and relative campaigns were mentioned as an approach that authorities and food producers should push seriously instead of over-exploiting the environment. Their perspectives covered the maximisation of law enforcement to the consumers and producers as well as increase the alternatives of sustainable products on the market. Participants expressed that they had to buy non-sustainable packaging because of limited options for desired food items.

I do think that government has the highest hand because they make the laws for the food companies. If they implement the laws as well for the consumers, everyone will have to follow these laws (Female, 21 years old).

There is no good of hoping for the goodwill of a few people when you can put it in laws and everyone supposed to follow (Male, 22 years old).

It is the manufacturers that have the opportunity to have the biggest impact because they can stop using a non-sustainable product (Male, 64 years old).

Why not we developed a brown paper bag that is strong enough to take vegetables, which can be disposed of and biodegradable? (Male, 60 years old).

Maybe giving people alternatives. Like the plastic bottle of water, but is there a carton of water in it? (Male, 34 years old).

These different perspectives of responsibility showed that participants viewed a wide range of aspects positively or environmental-friendly, even though there were some negative views on the performance of food producers and authorities. They also recognised their responsibility as consumers, while they still needed to have accessibility to personal requirements to behave in a sustainable way such as littering bin facilities for glass packaging in the neighbourhood, so they do not have to go to the glass bank. All these perspectives may influence consumers' purchasing decisions of eco-friendly packaging.

3.3.4.5 Eco-labelling issues and policy implications

Participants showed positive towards purchasing intentions of food products marketed using eco-labels. Benefits of eco-labels were related to the feeling of satisfaction and increased awareness of doing something good to reduce the negative impact of current packaging on the environment and future generations. The positive feeling towards eco-labels was counteracted by their concern of high prices of eco-friendly packaging. They said that this could affect negatively their intention to buy eco-friendly packaging and thus confirming that high prices of sustainable packaging are often perceived as a barrier by consumers (Magnier & Crie, 2015). However, there is a lack of studies indicating how much consumers are willing to pay for eco-friendly packaging.

If I did not have any kids and did not have a lovely granddaughter, I'd probably not worry about their future (Male, 50 years old).

I think there is that thing like, "I bought sustainable packaging." Pat myself on the back. You feel a bit good about yourself. I have managed to basically buy something that's environmentally healthy (Male, 22 years old).

Well if you have got a cheaper product in unsustainable packaging, I'd buy it. If it's 50 pence cheaper, I will buy the cheaper one (Male, 55 years old).

Is it going to affect the price? If not, I am going to like it (Female, 37 years old).

Consumers judge the eco-friendly attribute of packaging only at the moment of disposal (Colwill et al., 2012). However, participants were concerned about the lack of education among consumers in relation to packaging labelling and solid waste management at the household level. Discussion was characterised by strong arguments about what 'recycle' label should be used on food products in the UK because participants were unsure and perplexed of the disposal process. Some of them stated that they would not trust the sustainable claims or symbols printed on the label, referred to as 'loopholes', but only the brand of the product. Sustainability labelling is also different from product to product, and this adds more confusion during the process of purchasing decision. Therefore, participants agreed that the educational aspects of how to sort packaging waste, to improve the communication of eco-labels and to increase consumers awareness are important aspects of sustainable packaging development. Moreover, they added that reasonable information in the school

curriculum, social media, manufacturer website, product labels would help consumers to make more informed purchasing decisions.

But there need to be levels of increased awareness implemented by the government or by companies to make sure that the individuals are taking this increased action (Male, 21 years old).

We got one widely recycled on here. That's not completely recycled, is it? That is down to which council (Female, 54 years old).

Every single local authority in England and Wales has different has recycling policies (Male, 60 years old).

It could be just the colour of the label itself that requires it to be green. They should have some sort of standard way of putting the end of life of that product (Male, 50 years old).

I think they can be ambiguous, for example, widely recycled. It decides what widely is, widely could be seven counties. That's quite a wide area, but that's not a big area compared to the rest of the UK. Lack of detail can sort of.... you don't know what the benchmark is to start with (Male, 31 years old).

Lastly, an interesting aspect of labelling was highlighted by the elderly, who stated that labels appear to be difficult to understand and that packaging information is unreadable and too small. This could be a major drawback for the elderly if they want to understand how they can make their little contribution to sustainable issues.

Yes, the print has become smaller and smaller (Male, 50 years old).

Yes, the colour of the print, a well. Yes, it should be clear (Female, 54 years old).

Lastly, as stated in the literature review chapter, labelling is crucial to sustainable packaging because it helps consumers to handle the product in the correct manner (Jerzyk, 2016). The label is a communication platform for food producers and consumers to convey necessary sustainable information and to behave correctly. From the consumer point of view, labelling provides satisfaction and assurance to trust the products they buy (Lindh et al., 2016). Table 3.4 below displays the most familiar and most important sustainable labels that assisted participants in purchasing decision. Results show that 'certified disposal scheme' and 'certified source of packaging

material' were superior elements of labelling that help participants revealing their environmental behaviour. Approximately, 45% and 40% of participants chose the disposal scheme (e.g. OPRL) and trusted source of packaging material like Forest Stewardship Council. Similarly, both of the labels also important to the participants when they want to make a buying decision where 18% elected disposal scheme and 11% elected responsible packaging source.

Table 3.4: List of familiar and important sustainable food product labels

	Frequency	%
Most familiar packaging sustainable label		
Certified disposal scheme	45	26
Certified source of packaging material	40	23
Association with the environmental organisation	17	10
Certified scheme of involvement made with the purchase	16	9
Producer's personalised sustainable information	13	8
Environmental-related colour	2	1
Most important sustainable label on packaging		
Certified disposal scheme	18	38
Certified source of packaging material	11	23
Certified scheme of involvement made with the purchase	8	17
Producer's personalised sustainable information	7	15
Association with an environmental organisation	4	8

3.3.4.6 Consumer preferences of the sustainable packaging attributes

The second part of focus group analysis focusses on consumers' preferences of sustainable packaging attributes for 1 litre of milk gathered during the previous discussions. They selected the best attributes that will help them to show responsible environmental behaviour when choosing the milk packaging. The analysis shows interesting differences between participants younger than 46 and those older than 45. Figure 3.7 summarises these preferences by age group and provides insights for developing eco-friendly packaging.

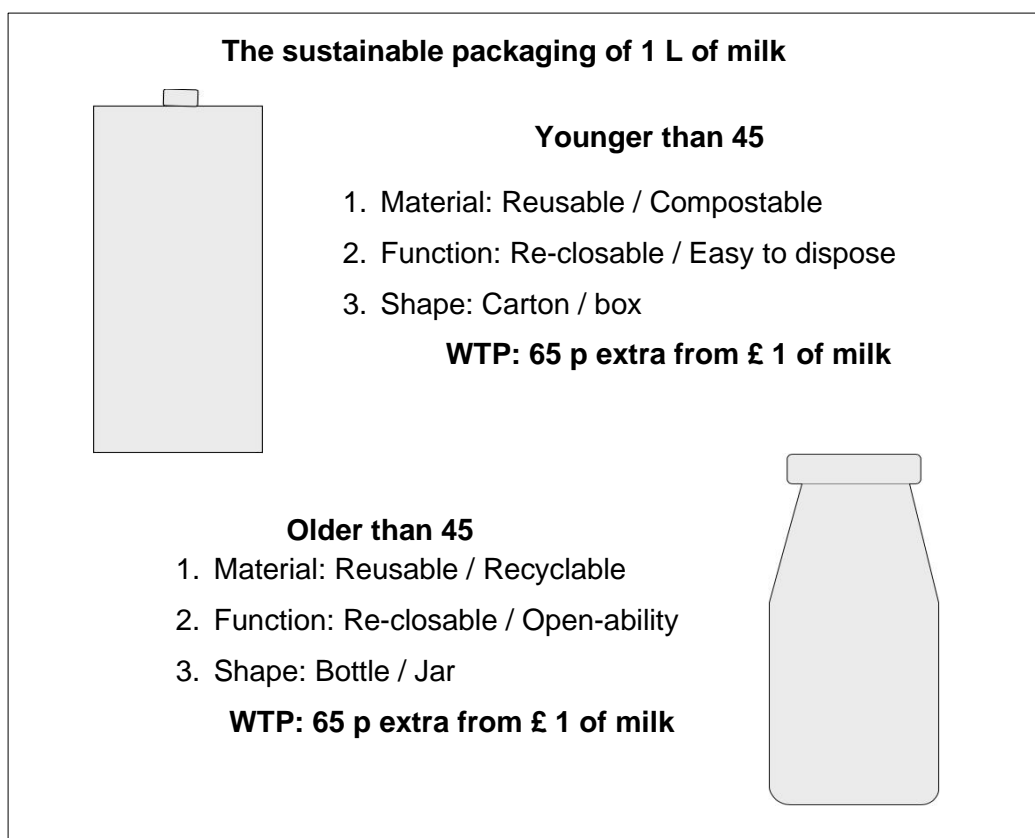

Figure 3.7: Hypothetical milk packaging by age groups

As regards packaging material, the identified eco-friendly options of these two groups show a convergence on reusability but a divergence on the way in which material should be disposed. Both groups believe that traditional packaging such as glass and metal can be reused at home and also reprocessed by the industry without generating more waste. However, the elderly found that ‘recyclable’ material is convenient and easy to discard due to the availability of facilities in the neighbourhood, while the younger group prefer ‘compostable’ material as it generates no waste for the environment. This difference can probably be explained by the fact that the group of young participants are aiming for zero-waste and on the contrary, the old generation is following the existing state of packaging waste disposal system in the UK.

With regard to the packaging function, both groups converge on “re-closable” because this is closely connected to the basic role of the packaging, i.e. preserving product quality and helping with storage. The “re-closable” function at the same time also attracted participants because it saves shopping time, especially for high-frequency shoppers. Interestingly, the older generation diverged on their second choice from the group of younger. The second best choice of the elderly is “open-ability” because

probably this function can help with physical disabilities that people in this group might face sooner or later in life. By contrast, the second best choice of younger participants was “easy to dispose of” because this function can avoid irresponsible littering action and increase daily commitments of this group. Bottle and carton were the most favourite forms of milk packaging shapes for the elderly and the young group respectively, and their choice was influenced by familiarity and storage availability at home.

The discussion triggered around the willingness to pay for the preferred sustainable packaging (Figure 3.7) does not show significant differences for these two groups. Both groups were willing to pay extra money for 1 litre of milk marketed with innovative sustainable packaging that they had identified during the focus group discussions. Surprisingly, both groups were willing to pay an extra 65 pence on average for the desired new packaging. This is an interesting aspect of product development because it is likely when end users become co-creators of the innovation, they are willing to pay more than when the innovation is developed in the lab without involving consumers. Thus, more attention should be given to the concept of presumption when developing innovative sustainable packaging. However, most participants also stated that even if they were ready to spend a reasonable extra amount of money for eco-friendly packaging, food prices should not be affected by packaging and should be part of the quality of the food product. This extra 65 pence of qualitative results could be explained that consumers always show positive reaction towards something that benefits to the environment (Singh & Pandey, 2018; Zhao et al., 2018), even though they might not actually react the same way in the real market situation.

3.3.5 Conclusion of focus group discussions

Focus group discussions conducted in this study stimulated the pro-environmental behaviour of participants towards aspects of eco-friendly packaging. Although some studies in environmental psychology reported low correlations between self-reported and observed behaviours (Steg & Vlek, 2009), this study shows that participants were concerned about the environment, and willing to give up some of their personal preferences by buying new sustainable packaging. Despite the fact that there some participants complained about the price and preferred something cheaper, the extra 65 pence of WTP on average might be considered a positive indicator that people are willing to spend on day-to-day if the quality and nutritional content of food product is preserved and not been compromised. These findings also underline the effect of

market maturity in terms of consumer awareness regarding environmental problems in our society.

Although participants took responsibility for the current packaging design and a stockpile of the waste, they also emphasised that food producers and authorities should do more to help consumers to make more informed choices. Participants perceived that when food producers create sustainable packaging, they make consumers feeling confused because they prioritise profit and not communication and innovation for end-users. Moreover, in line with other studies (Okuda & Thomson, 2007; Vasileva & Ivanova, 2014), participants also felt that authorities must be responsible for reducing waste by enforcing current legislation with new rules for food producers. For example, reduction in municipal waste tax for the businesses that involve in sustainable packaging might be resulted in lower price of the new sustainable packaging. It will benefit not only to the food producers but also consumers and the environment as well.

Participants perceived positively towards environmentally-friendly packaging and thus these results corroborate past studies that indicate great consensus among consumers as long as not risking their well-being and quality of products (Eldesouky, Pulido & Mesias, 2015; Lindh, Olsson & Williams, 2016). However, the absence of personal requirements such as lack of storage and financial resources generated a hesitant state of mind among participants when they had to think about buying innovative sustainable packaging. Moreover, the buying behaviour of some the elderly participants was a bit at odd because they preferred to choose loose groceries instead of packaging even if they supported the introduction of new sustainable packaging. They stated, “generate no waste is better than create a new one”.

Results also indicated that age is an important demographic characteristic to discriminate participants' attitudes towards the environment. Eventually, generation gaps, experiences and not only age influence the adoption of a new habit adapt that requires everyday action like buying grocery (Schmidt et al., 2014). The old and young groups show significant differences in the selection of sustainable attributes and these aspects must be considered when launching on the market eco-friendly packaging. For the function attributes the older group prefers open-ability because the ageing process it is likely to cause physical disability (Thompson & Thompson, 2009) and ergonomic packaging such as larger prints requires less effort than other function attributes (Galley, Elton, & Haines, 2005; Sudbury-Riley, 2014). Whereas, the younger group

selected easily dispose of packaging due to their work commitments. Most of the participants were workers or students who desired hassle-free products to reduce time pressure caused by the daily routines.

Despite that, findings still disclosed that convenience and food quality are the most important factors in purchasing decisions. The packaging exists to protect the food, and if changes of packaging styles could shorten the shelf-life or defect the taste, the innovation is unacceptable for the consumer (Jimenez-Guerrero, Gazquez-Abad & Ceballos-Santamaria, 2015). The 're-closable' attribute was the primary option for young and old participants because this packaging attribute will keep the freshness and long-lasting good quality of the milk. Moreover, the participants appeared to support innovative sustainable packaging, but they still preferred carton or bottle for milk because these shapes were familiar and looked sustainable to them as they assumed that carton is made from paper and bottle is glass. Familiarity is an important aspect of eco-friendly packaging development because unfamiliarity with terminology or appearance related to sustainability can cause a drawback of pro-environmental behaviour (Jerzyk, 2016).

The results indicate that the challenge for food producers appears to be how to design sustainable packaging that simultaneously benefits the user and the environment while keeping future sales at acceptable levels. Increased knowledge about consumers' views on eco-friendly packaging is essential to understanding consumer choice and build a compelling product story around sustainability with innovative designs for sustainable packaging. Moreover, the results of this exploratory study provide policymakers with relevant recommendations to promote the adoption of eco-designed food packaging to food producers and consumers. Implementation of these novel findings can also act as a first step towards the improvement of sustainable packaging design practice because also small enhancements can be significant when multiplied by the enormous number of products sold in the market ultimately. Finally, insights from focus groups discussion and in-depth interviews have been paramount to develop the quantitative study presented in the next chapter.

CHAPTER 4

QUANTITATIVE STUDY: RESEARCH METHODOLOGY AND DESIGN

4.1 Introduction

This part of the thesis explained the research design, which includes research philosophy, methods, instrument, data collection process and approaches of data analysis employed in this study. The chapter begins with the research philosophy and quantitative techniques chosen for this study. The research philosophy is explained regarding the possible way to understand consumer decision-making processes and how a researcher could observe these processes. Meanwhile, two approaches of research techniques (psychological survey and the stated preference method) then are explained in detail on how they are implemented in this study. The next section of this chapter will describe the instrument design used in data collection. It contains the framework of the questionnaire which includes the environmental variables of the pro-environmental model, the contingent valuation of WTP, the attributes and the levels for innovation of sustainable food packaging which will be tested in the choice experiment (CE). Finally, the chapter continues with the implementation of the data collection procedure. It includes the description of the target population and the sampling technique used to meet the requirements of this research context. Moreover, the pilot study and the modification made of the research instrument are also explained in this part of the chapter. The chapter ends with the data analysis section. This section also explained the applications of software and the steps to generate results which further link to the next chapter.

4.2 Research philosophy and adopted research strategy

Research philosophy describes the way of development of knowledge and the nature of that knowledge. Saunders, Lewis and Thornhill (2007) explain the way knowledge development contains important assumptions about how the research is designed on purpose to answering a specific problem of interest in a particular field. Specifically, the main influence of research philosophy is likely to be a particular view of the relationship between knowledge and the process by which it is developed. It includes the research strategy such as methods and its practical considerations to gather and analyse the knowledge. Based on the research questions related to the consumer attitudes towards purchasing innovative sustainable food packaging concerning their environmental values, this research can be classified as a positivist, interpretive with

the deductive approach. Different from explorative studies such as in-depth interviews and focus groups discussed in chapter three, where more subjectivism was needed to explain social aspects of eco-friendly packaging, this chapter is concerned with research questions and objectives aimed at identifying consumers' values and preferences towards sustainable attributes of food packaging.

Moreover, because this part of the study gathers facts to understand the phenomena and improving the problem, it may also be categorised interpretive as it is likely to use existing theory to develop the hypothesis (Saunders, Lewis & Thornhill, 2007). Positivist research argued to be uncritical enough into complex situations, such as understanding differences between consumers as social actors (Gall et al., 2002). The use of theories like value-belief-norms (VBN) and random utility theory to observe this problem was used to test assumptions of decision making and interpret and understand consumers' attitudes and values. To generate credible data from positivist research, it is crucial to test, confirm and interpret the assumptions generated from these theories which will lead to further development of knowledge of consumers' purchasing behaviour of innovative sustainable packaging. Therefore, a quantitative survey employing models of social psychology and stated preference techniques will be employed in the remaining part of this study.

Surveys are usually associated with the deductive approach, a very popular research strategy in marketing and business studies to answer questions investigating such how much, who, where, and what. Furthermore, the survey method allows researchers the collection of data from a large sample of the target population as the questions are standardised and give more control over the research (Saunders, Lewis & Thornhill, 2007). In this research, a survey was developed to collect data that suggest possible relationships between preferences of sustainable packaging and consumer's values, beliefs and norms of environmental protection.

In this study, an experimental strategy was considered the most appropriate research approach as a representation of consumers' pro-environmental purchasing behaviour for sustainable packaging. An experiment is a classical form of research that owes much to the study of the natural sciences. However, it is becoming commonly used in many marketing studies as stated preferences. A stated preference experiment aims to study causal links whether a change of one independent variable will make a change in another independent variable (Hakim, 2000). This method, which will be explained in detail later, tend to explain 'how' and 'why' a dependent variable like purchasing behaviour might or might not change when an attribute alteration occurred. This

experimental strategy is crucial to understand what attributes drive the market of eco-friendly products and thus to balance design decisions for optimal sales and revenues (Hoffenson et al., 2015).

Another stated preference technique, contingent valuation, was also part of the survey to better understand how much consumers are willing to pay for innovative eco-friendly packaging. Contingent valuation techniques also estimate WTP for non-market goods, but in monetary values for them as a whole rather than for a bundle of its attributes like choice experiments (Mitchell & Carson, 1989). Instead of focusing on a particular product (milk packaging), this technique was used to explore to explore daily WTP expenditure for innovative sustainable packaging. These conceptual frameworks and methods will be explained in the next section of this chapter.

4.3 Operationalisation of the pro-environmental behaviour conceptual framework

The United Nation defines pro-environmental behaviour as 'the use of services or any related products which respond to basic needs and bring a better quality of life while it is minimising the use of natural resources and increase usage of non-toxic materials as not to jeopardise the needs of future generations' (Park & Ha, 2012, p. 389). The most commonly cited the definition of pro-environmental behaviour found in the literature is 'pro-environmental behaviour is an action that harms the environment as little as possible or even gives benefit to the environment' (Steg & Vlek, 2009, p. 309). The definition treats pro-environmental behaviour as an individual level phenomenon where an individual portrays the self-ecological values or attitudes to the actual environmentally friendly activities. Similarly, both definitions of pro-environmental highlighted in making the change of behaviour towards lessening the negative effect of actions on the natural climate.

In order to match these concepts, a conceptual framework was developed, combining models of pro-environmental behaviour and economics. A similar approach was used in two studies exploring suburban park conservation and environmental preservation movement in general (Chen, 2015; Lopez-Mosquera & Sanchez, 2012). Moreover, there is a growing interest in research to understand how psychosocial values and attitudes of individual responses can influence environmental purchasing behaviour. According to Sauer and Fisher (2010), past studies show that adding psychological values to demographic characteristics can improve both econometric estimates and the explanation ability to understand public involvement for a particular behaviour. Non-monetary values such as ecological values, beliefs and norm can provide more

insights and knowledge to the literature on how the consumer decides to act environmentally friendly. For example, a study proved that motivational factors such as attitudes towards the environment are important to understanding consumers' WTP intention better (Spash, 2000). Therefore, it is worthwhile to combine psychological and econometric models to estimate and understand pro-environmental behaviour towards sustainable food packaging alternatives.

Figure 4.1 shows that in this study, pro-environmental behaviour was captured using the VBN model. This model was developed by Stern et al. (1999) and is an extension of the Norm-Activation Model, and the New Environmental Paradigm (NEP) used to predict pro-environmental behaviour. Initially, this social-environmental model had been used as the core theory for most environmental psychology studies to understand the 'environmentally significant behaviour' of a person (Jansson, Marell & Nordlund, 2011). The model was commonly used to investigate pro-environmental behaviour among consumers on innovation regarding energy conservation or any environmental activism, while NEP is perhaps the most widely used social psychological measurement scale in the literature of environmentalism (Stern et al., 1999).

The VBN model was improved further in order to explain an individual's underlying reasons for pro-environmental actions such as policy support, environmental citizenship and activism (Stern, 2000). The VBN recognises that personal values are capable of perceiving risks and benefits of any actions affecting environmental sustainability (Payne, Bettman & Johnson, 1992). However, as far as this study is concerned, there is a lack of studies acknowledging the use of VBN framework on consumer choice of food packaging (van der Werff & Steg, 2016) and thus in order to fill this gap VBN was employed to gain a better understanding of purchasing pro-environmental behaviour of innovative sustainable packaging in the UK.

Figure 4.1 illustrates that three ecological values (altruistic, biospheric and egoistic) are placed at the beginning of the proposed framework. The central part of the proposed model includes both the NEP that determines the level of environmental concern of innovative sustainable packaging and the beliefs of sustainability determined awareness of consequences (AC) and ascription of responsibility (AR). AC and AR are psychological experiences that individuals face in daily routines, and this used to assess how they perceive awareness of consequences of food packaging waste and a sense of responsibility towards these problems. These elements also activate the last part of the VBN framework, represented by personal norms (PN). PN is used to understand whether the impact of packaging waste will be reduced in future. Finally,

the innovative aspect of the proposed VBN model is that actual pro-environmental behaviour was substituted with purchasing behaviour of innovative sustainable food packaging and thus in this study, actual pro-environmental behaviour highlighted is represented by participants' WTP of eco-friendly food packaging. To date, this appears to be the only study estimating consumers' WTP for eco-friendly packaging using this approach.

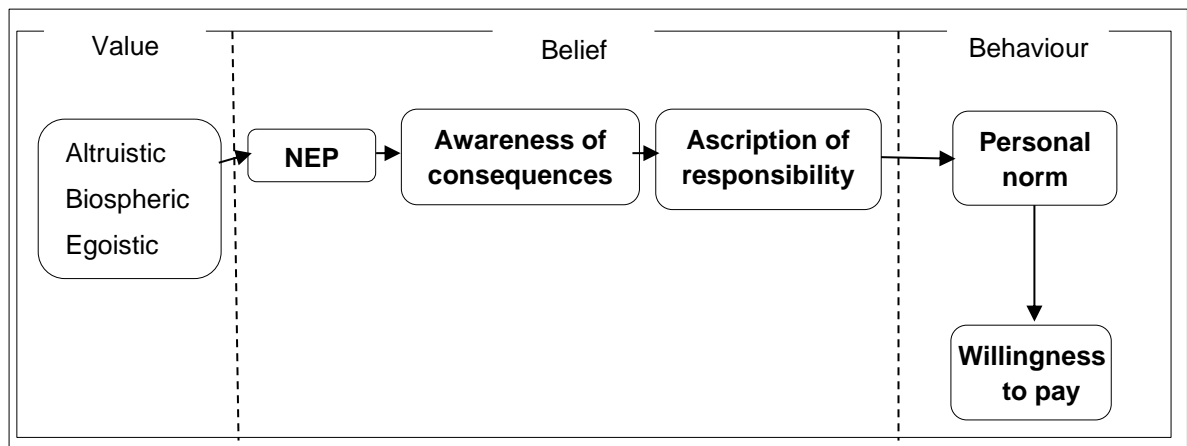

Figure 4.1: Conceptual framework of the study

In order to operationalise the conceptual framework illustrated in Figure 4.1, a questionnaire containing the following five sections was developed (see Appendix 12): 1) psychological constructs of the VBN model, 2) milk shopping habits and knowledge of sustainable packaging, 3) WTP for innovative eco-friendly milk packaging attributes, 4) WTP for food products marketed with innovative sustainable packaging and 5) socio-demographic and economic characteristics of participants (gender, age education, income, etc.).

The survey was developed using the QUALTRICS web platform and started with two filters questions that had the scope to select only respondents who consumed dairy milk and were responsible for grocery shopping at home. Furthermore, while the last section is typical of all surveys and contain variables that may or may not affect the pro-environmental behaviour of respondents, the first four sections are specific of the research design developed for this study, and thus they will be explained in detail hereafter.

4.3.1 Measurements of values, beliefs and norms

In line with the conceptual framework presented in Figure 4.1, the first section of the questionnaire had the scope to collect information about the egoistic (EGO), altruistic (ALT) and biospheric (BIO) of personal ecological values of respondents (see Appendix 12). In order to achieve this objective, this study adapted an established scale of the three ecological beliefs used in many environmental behaviour studies. This scale was developed and tested to differentiate the orientations of egoistic, biospheric and altruistic environmental beliefs (De Groot & Steg, 2008). The scale was composed of a 12-itemised rating scale with four items for each construct. Each item was measured on a 9-point scale starting from -1 (as opposed to my principle) and continuing with 0 (not important at all) up to 7 (extremely important).

Theoretically, these variables are constructed to predict the consumer's environmental identity and capture environmental personality in more general situations. The egoistic value focuses on the costs and benefits of choices that influence the resources that people have by social power, wealth, authority and influential relationships. These constructs are typically negatively correlated with pro-environmental beliefs, attitudes, preferences and behaviour (De Groot & Steg, 2007; Nordlund & Garvill, 2002). Stern et al. (1995), Steg, et al. (2011) and Steg and De Groot (2012) suggested that an individual is less concerned about the environment when he cares much about personal gains as reflected in the strong egoistic value. Instead, biospheric is a self-transcendence value that concerns the quality of nature and the environment for its own sake, without a clear link to the public welfare. As such, it differs from the altruistic value that reflects a concern for the welfare of the public (Steg et al., 2014). Generally, both values are positively correlated to pro-environmental beliefs, attitudes, preferences and behaviours (Stern et al., 1995; Steg et al., 2011; Steg & De Groot, 2012). Also, these two values are related, but generally, altruistic is measured by equality, world peace, social justice and helpful construct items, while biospheric is measured by pollution prevention, respecting other species, unity and environmental protection items. Table 4.1 shows how these values were measured in this study. Eventually, these ecological values are hypothesised to influence environmental beliefs of NEP and to predict individuals level of environmental awareness.

Table 4.1: Summary of EGO, ALT and BIO items

Items	-1	0	1	2	3	4	5	6	7
E1 Social power: control over others, dominance									
E2 Wealth: material possessions, money									
E3 Authority: the right to lead or command									
E4 Influential: having an impact on people and events									
A5 Equality: equal opportunity for all									
A6 A world at peace: free of war and conflict									
A7 Social justice: correcting injustice, care for the weak									
A8 Helpful: working for the welfare of others									
B9 Preventing pollution: protecting natural resources									
B10 Respecting the earth: harmony with other species									
B11 Unity with nature: fitting into nature									
B12 Protecting the environment: preserving nature									

E1,E2,E3,E4 are EGO items

A5,A6,A7,A8 are ALT items

B9, B10,B11,B12 are BIO items

As regards NEP, Stern (2000) stated that NEP is a well-known systematic published scale that is activated by individuals' values. The NEP scale aims to investigate ways in which human being behaviour damages the natural environment as shown in many environmental behaviour studies (Chen, 2015; Hawcroft & Milfont, 2010; Jansson, Marell & Nordlund, 2011). For example, NEP was used to identify the level of environmental concern of an individual, whether high, moderate or low towards environmental protection (Jansson, Marell & Nordlund, 2011). By the same token, this research applies the NEP scale to determine the level of environmental concerns among consumers in the UK. The scale consists of fifteen items identifying five environmental constructs that examine multiple environmental phenomena such as pollution and depletion of natural resources but also individuals concern such as beliefs and behaviour towards the phenomena (Dunlap & Jones, 2002). The five constructs are 'reality of limits to growth', 'anti-anthropocentrism', 'fragility of nature's balance', 'rejection of exemptionalism' and 'possibility of an eco-crisis'. Each construct contained three items measured on at 5-point Likert scale ranging from '1 strongly disagree' to '5 strongly agree' (Dunlap et al., 2000). When respondents score 1 or 2 on these fifteen NEP items, they have low environmental awareness, while scores of 4 or 5 scores indicate high environmental awareness. Thus, NEP uncovers the level of environmental awareness, which will be used to identify respondents' pro-

environmental purchasing behaviour of sustainable food packaging. Table 4.2 shows the fifteen items used in this study.

Table 4.2: Summary of NEP items

	Items	1	2	3	4	5
N1	We are approaching the limit of the number of people the earth can support.					
N2	Humans have the right to modify the natural environment to suit their needs.					
N3	When humans interfere with nature it often produces disastrous consequences.					
N4	Human ingenuity will ensure that we do not make the earth unlivable.					
N5	Humans are seriously abusing the environment.					
N6	The earth has plenty of natural resources if we just learn how to develop them.					
N7	Plants and animals have as much right as humans to exist.					
N8	The balance of nature is strong enough to cope with the impacts of modern industrial nations.					
N9	Despite our special abilities, humans are still subject to the law of nature.					
N10	The so-called 'ecological crisis' facing humankind has been greatly exaggerated.					
N11	The earth is like a spaceship with very limited room and resources.					
N12	Humans were meant to rule over the rest of nature.					
N13	The balance of nature is very delicate and easily upset.					
N14	Humans will eventually learn enough about how nature works to be able to control it.					
N15	If things continue on their present course, we will soon experience a major ecological catastrophe.					

Before collecting information for the other constructs of the VBN model (AC, AR and PN), participants were provided with the following information explaining the food packaging waste and the importance of developing innovative eco-friendly packaging:

The excessive use of landfill to dispose of food packaging waste and its accumulation in the environment has triggered sustainability campaigns which aim at increasing consumers' awareness of this contemporary issue. As a result, the UK food and drink industry are paying attention to new packaging that should be used to market food products to consumers. Therefore, the development of packaging called 'sustainable packaging' is attracting attention from the food and drink industry as well as the UK Government, which is supporting innovative packaging with regulations aimed at protecting consumers and the environment in the long run.

This part of the questionnaire also included the definitions of food packaging, food packaging waste and sustainable packaging in order to allow respondents to think of the consequences of unsustainable packaging. Participants were also asked to state their familiarity and understanding of these concepts (see Appendix 12).

As a result, AC items were designed to measure an individual's level of awareness on environmental consequences created by current food packaging waste. This construct was developed to measure the specific environmental problem related to food packaging waste globally and locally. Table 4.3 shows the nine items that were created to measure this construct. Five items were adapted from past pro-environmental behaviour studies (recycling behaviour, food shopping habits and purchasing of eco-friendly products), while four items were created to fit the purpose of this study on the basis of qualitative findings and past studies, e.g. the survival of recycling business depends on the waste (Weir, Taylor & Welsh, 2012) and costs of disposal that local councils have to face every festive season (Sheffield, 2016). All items were measured on a 5-point Likert scale ranging from 'strongly disagree' to 'strongly agree.'

Table 4.3: Summary and sources of the AC items

	Items	Sources
AC1	Food packaging waste contributes to biodiversity loss	van Riper & Kyle (2014)
AC2	Food packaging waste continues to raise pollution to the environment	Jansson et al. (2011)
AC3	Food packaging waste leads to decreasing individual's well-being by contaminating the environment with hazardous waste	Onel & Mukherjee (2015)
AC4	Without food packaging waste, it is difficult to maintain the safety and quality of food products*	**
AC5	Food packaging waste causes the depletion of non-renewable natural resources such as fossil fuels	Williams et al. (2012)
AC6	Food packaging waste will damage this planet further	Richter (2017)
AC7	Food packaging waste is necessary because without it people working in the packaging industry will lose their jobs*	**
AC8	Food packaging waste requires high disposal costs to handle and process waste on site	**
AC9	Reducing food packaging waste will cause a loss of monetary benefits for people involved in managing and selling it *	**

* Reversed scores

** New items

The AR construct is used to examine the degree to which consumers ascribe personal responsibility towards environmental problems (Onel & Mukherjee, 2015), and in this study it was used to identify feelings of individuals' responsibility toward preventing the packaging waste problem. Like AC, also the AR construct was captured using nine items measured on a 5-point Likert, as shown in Table 4.4. In this case, six items were adapted from two environmental studies on recycling behaviour (Onel & Mukherjee, 2015; Richter, 2017) and research conducted on purchasing an eco-friendly car (Jansson, Marell & Nordlund, 2011). The remaining three items were created considering aspects of the current food packaging situation in the UK, such as 5 pence grocery bag. These new items explored individuals' shopping habits and household waste management such as disposal of food packaging at home, food consumption and shopping plan for household products.

Table 4.4: Summary and source of the AR items

	Items	Source
AR1	I feel personally responsible for the environmental problems resulting from my disposal behaviour of food packaging that is not eco-sensitive	Onel & Mukherjee (2015)
AR2	I feel personally responsible for the increase in food packaging waste when I care less about discarding my food packaging in correct bins available	Jansson et al. (2011)
AR3	When I go shopping, I only buy food items that I consume because I do not waste food and unnecessary food packaging	Richter (2017)
AR4	When I go shopping for my food items, I always choose packaging which is environmentally friendly	**
AR5	In principle, sole individuals like me cannot contribute to the decrease in food packaging waste*	Jansson et al. (2011)
AR6	Usually, I seriously consider what I buy before purchasing to avoid the risk of pollution caused by the disposal of my food packaging	Richter (2017)
AR7	I follow the instructions/leaflets given by authority at all times on how to discard food packaging waste at home	**
AR8	I take care of not consuming food products before they spoil to avoid unnecessary increase of food packaging waste from my home	Richter (2017)
AR9	When I go shopping for my food items, I never buy the 5-pence plastic bags	**

* Reversed scores

** New items

PN is the last component of the VBN variable before the pro-environmental action of section 3. PN measured an individual's internal expectations of how he or she should react to the environmental problem without any social influences but based just on the inner's belief (Stern, 2000). At this point in the questionnaire, respondents were introduced to the sustainable food packaging idea and their general opinion on the changes they would make to act environmentally friendly with the sustainable packaging option in the market. As same as previous constructs, PN constructs contained nine items of 5-point Likert scale ranging from 'strongly disagree to strongly agree'. Two items of PN have measured respondents' perceptions on the sustainable packaging purchasing behaviour; while others were asked about the food shopping, meal and household food plan to reduce the waste production from an individual. Table 4.5 summarised the items and adopted sources of PN variable. Only two items were contextually constructed based on the current situation in the UK and qualitative results. For example, according to the focus group participants, they would like to re-use the milk packaging to make something creative at home and likely to purchase loose food product rather than packaged one to avoid more solid waste. However,

other items of PN were adopted and adapted from previous pro-environmental behaviour studies relevant to this research.

Table 4.5: Summary and sources of the PN items

	Items	Source
PN1	I should plan my meals for several days to dispose of food packaging more efficiently in the future	Williams et al. (2012)
PN2	I personally feel that it is important to think about the environment when I make purchase decisions to buy food products	Jansson et al. (2011)
PN3	I would be a better person if I consume sustainable food packaging which is environmentally friendly	Jansson et al. (2011)
PN4	I feel a moral obligation to dispose of all my food packaging waste correctly into appropriate bins	Onel & Mukherjee (2015)
PN5	I feel guilty when I do not protect the environmental quality by using non-sustainable food packaging	Onel & Mukherjee (2015)
PN6	I have a very bad conscience when I dispose of expired food because I also generate more packaging waste	**
PN7	If I have to change my shopping behaviour today, I would feel a moral obligation to replace my current choices with food products that use sustainable packaging even if they cost more	Jansson et al. (2011)
PN8	Personally, I feel that it is important to choose food products that use packaging material as little as possible	Williams et al. (2012)
PN9	I would consider myself a better person if I make the best use of the food packaging waste at home such as re-use it	**

** New items

4.3.2 Milk shopping habits and knowledge of sustainable packaging

In line with the qualitative study, also the quantitative study explored consumers' preferences for innovative sustainable packaging, estimating WTP for eco-friendly milk packaging. As a result, this section of the questionnaire had the scope both to elicit respondents' milk consumption habits of fresh milk of respondents and to introduce them with information about alternative sources of bioplastic. As regards consumption milk habits, participants were asked to state weekly consumption of fresh milk, type of fresh milk that they usually buy, shopping frequency, shopping place, and their preferences for both type of packaging and type of disposal (see Appendix 12).

Consumption habits were followed by cards explaining participants different sources of bioplastic, their biodegradable disposable options and questions exploring their knowledge of innovative sustainable packaging. The use of this information was an important aspect of the survey because some respondents could be not sufficiently informed about the topic and thus their ignorance could have impacted negatively on

the evaluation of attributes of the choice experiment presented in the next section. In order to tackle this problem, respondents were provided with a short explanation of innovative packaging terms contained in the choice experiment, as shown in Figures 4.2 and 4.3. Thus, this type of information was important to minimise the number of respondents that could have been unable to express their preferences and WTP (Bateman et al., 2002) for eco-friendly packaging.

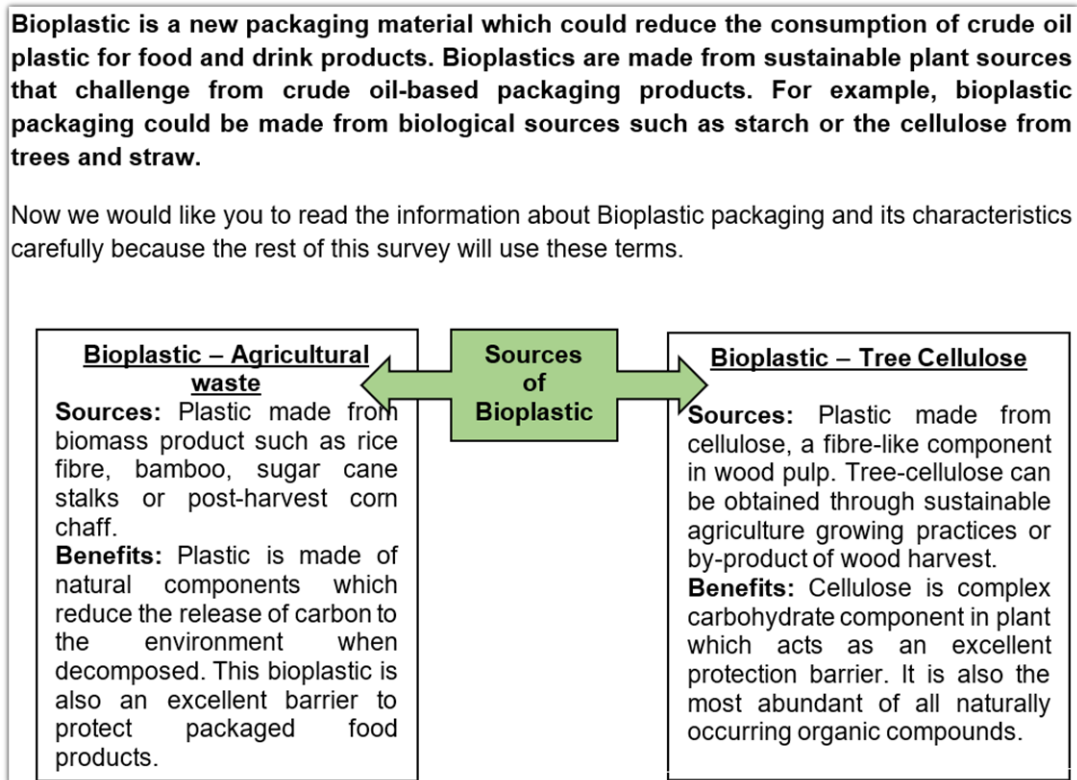

Figure 4.2: Information of alternative sources of bioplastic

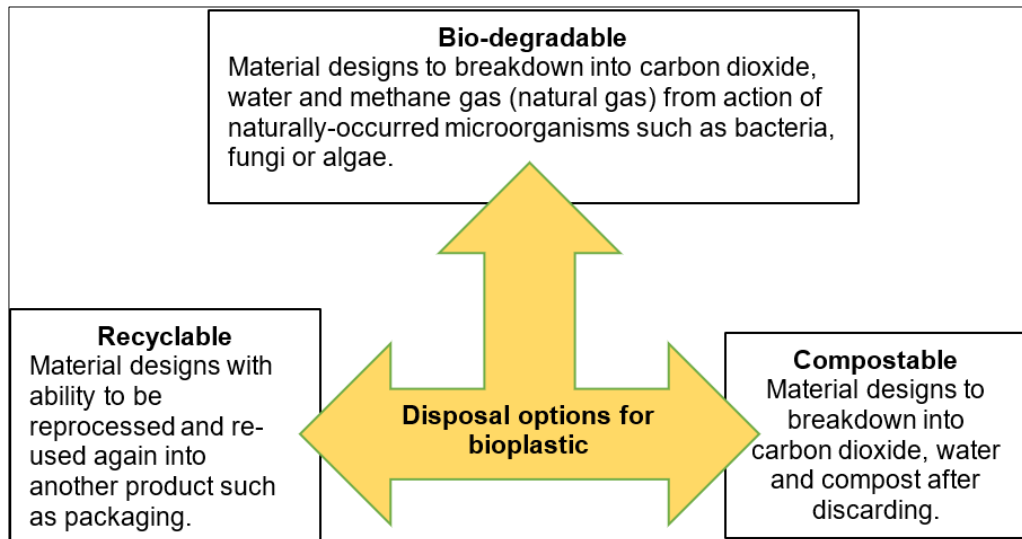

Figure 4.3: Information on bioplastic disposal options

4.3.3 Measurement of WTP of innovative sustainable packaging

This section of the questionnaire was developed on qualitative research conducted with experts and consumers. According to qualitative findings presented in chapter 3, there is a need to reduce the use of packaging material finding alternatives which make more extensive use of biomass by-products (e.g. bioplastic) capable of replacing synthetic materials like fuel plastic. Bioplastic obtained from plants appears to be one of the most innovative packaging materials. Bioplastic is a bio-based polymer that is derived biologically from renewable agricultural organic material such as wood residues, grasses, agricultural crops and its by-product (Onwezen, Reinders & Sijtsema, 2017). Research and innovation of bio-based polymer such as bioplastic development are driven by the limited volume of landfill capacity, excessive use of fossil-fuel, the bad image of plastic waste as well as increases of crude oil price (Hermann, Blok & Patel, 2010). The bioplastic material offers one of the few sustainable alternatives for food packages to reduce excessive waste and dependence on the non-renewable natural source. As a result, this part of the questionnaire focused on how WTP for this new packaging material was elicited via stated preference and contingent valuation methods.

4.3.3.1 The choice experiment of innovative bioplastic for milk packaging

The theoretical grounding of stated choice methods is in Lancaster's model of consumer choice (Lancaster, 1966) while their econometric foundation in the random utility model (RUM) (McFadden, 1974). The Lancaster theory assumes that consumers

derive their utility not from goods themselves but from their characteristics or attributes. Thus, the Lancasterian approach postulates that each consumer chooses a single option yielding the greatest utility (McFadden, 2001; Train, 2003).

The theory of Lancaster also provides a theoretical framework that helps researchers to analyse the demand for differentiated products because it deals explicitly with segments of consumers who make mutually exclusive choices from a set of substitutable goods. The fundamental econometric approach to assessing consumer preferences within a discrete choice multi-dimensional environment is via RUMs. RUMs are based on the hypothesis that individuals make choices according to attributes of alternatives characterised by a degree of randomness (Adamowicz, Louviere & Williams, 1994; McFadden, 1986; McFadden, 2001). However, in order to create these hypothetical choices a discrete choice experiment design must be developed.

An ideal choice experiment design requires two significant steps that allow researchers to evaluate appropriate trade-offs between product characteristics following the underlying economic theoretical framework with compensatory decision-making. First, there are no general guidelines for a maximum number of attributes, but the selection of attributes and its levels depend on the research context and goals of choice experiments (Louviere, Hensher & Swait, 2000). However, these studies rarely include all important attributes but only the most relevant to the majority of respondents. When researchers include all attributes, respondents will be burdened with too much information, which can affect the validity of the choice experiment (Klojgaard, Bech & Sogaard, 2012). Attributes included in choice experiments can be quantitative or qualitative and are based on knowledge gathered from in-depth interviews, focus group, literature reviews and expert opinion (Coast & Horrocks, 2007).

Second, the design process has to determine significant levels for each attribute of hypothetical products under investigation. These levels must have a range that captures and ensures trade-offs between attributes while still being acceptable to the respondent (Klojgaard, Bech & Sogaard, 2012). Moreover, the designed experiment must be easy to comprehend, and its scope should be relevant and appropriate. If the scope is inappropriate, respondents might consider differences between levels to be unimportant, and thus, a certain level might dominate another level of the same attribute (Lancsar & Louviere, 2008).

The starting point to develop the choice experiment of this study and ensure that respondents could comprehend and process information with an acceptable cognitive

effort are the results of the qualitative study. Table 4.6 shows that the most salient attributes, relative levels and reasons identified by focus group participants uncovered a detailed description of salient options that might explain participants' purchasing intention of eco-friendly packaging. These findings clearly show that packaging material is the key aspect of sustainability and that bioplastic can add value to the food industry because it reduces waste, allows stakeholders to use resources efficiently and increases sustainable options. Participants were positive towards the packaging material from renewable resources such as paper, glass and bioplastic if it brings no harm to the environment and keeps the food safe. Furthermore, in line with the qualitative study, also the choice experiment explored WTP for innovative eco-friendly milk packaging, and thus, fresh milk was chosen as the product contained in the bioplastic packaging.

Table 4.6: Association between attributes, salient options and explanations

Attributes	Salient options	Reasons
Material	Bioplastic Glass Paper-based	Save for environment Waste reduction
Disposal option	Compostable Reusable Recyclable	Create no extra waste to environment Availability of disposal bins at home
Shape	Bottle or jar	Familiarity No spilling when stored
Label	Certified disposal scheme Certified source of material	Assurance sign
Functionality	Re-closable Easy to dispose Open-ability	Save time Keep the food longer User-friendly
Price	65 pence extra from £1	Keep environment clean Reduce waste

4.3.3.2 Selection of salient attributes and relative levels of sustainable packaging

The choice and description of attributes and relative levels are critical to the success of choice experiments. Levels refer to values of an attribute, and they can be qualitative or quantitative. Levels of an attribute are an important aspect of choice experiment designs because the number of levels to be included in an experiment impacts the complexity of choice tasks being presented to respondents. To limit the complexity of these designs, an experiment should limit the number of attribute levels presented but at the same time, reflect the real market situation. Thus, respondents will be able to build an efficient way to process the information by using existing experience (Zwerina,

1997). This suggests that the levels of packaging attributes must reflect those that are available on the current market, and attributes and relative levels should be plausible and related to respondents' experience and knowledge (Louviere, Hensher & Swait, 2000). In this study, this was ensured by identifying the following four attributes: bioplastic, disposal options, certification label and price (Table 4.7). Shape and functionality (see Table 4.7) were excluded from the list of attributes because participants repeatedly mentioned a bottle or jar and the three packaging functions (e.g. easy to dispose of, re-closable and open-ability) are what they buy by-default from supermarkets.

Table 4.7: Attributes and its level of bioplastic milk packaging

Attributes	Level 1	Level 2	Level 3	Level 4	Level 5
Bioplastic	Tree cellulose	Agricultural waste			
Disposal options	Recyclable	Compostable	Biodegradable		
Certification label	Yes	No			
Price	5%	10%	20%	40%	80%

Bioplastic is produced from a bio-based material which can be made from partially or fully organic material. The UK bioindustry appears to be interested in fully bio-based plastic because this material can reduce packaging waste, use excessive renewable natural resources efficiently and increase the competitiveness of the bio industry in the UK (CEBR, 2015). The two major sources of bioplastic on which the food packaging industry is investing are agricultural waste (e.g. starch and protein from leaves, crop stems, peels, straws) and other green wastes. Starch and plants protein from agricultural waste are becoming an increasingly popular source of raw material for the plastic product (Gomez-Heincke et al., 2017) and are one of the most abundant and low-cost resources that can be easily found in agriculture. Starch and plant protein consist of most versatile organic components that are not only biodegradable but also mechanically strong water-resistant barriers suitable for many applications such as packaging (Gomez-Heincke et al., 2017; Sagnelli et al., 2016). Ongoing research is still trying to improve the mechanical properties of this agricultural waste in order to increase heat resistance and anti-microbial properties (Liang et al., 2018; Vadori et al., 2013).

Interestingly, another source of bioplastic can be obtained from tree cellulose (forestry industry). Cellulose is a fibre-like carbohydrate compound, which is the main component to build up tree branches and wood trunk (Fernandes et al., 2011). Tree

cellulose is a promising new bio-based material that is naturally water resistant and strong thermal resistant (Agustin et al., 2014). The fibre-like structure made cellulose is very difficult to dissolve or melt, and it is proven to be stronger thermal resistant than conventional plastic (Wang et al., 2013). This cellulose compound has been used in many forms such as plastic films and sheets as the results of good strength, toughness, transparency and high surface gloss (Yano et al., 2013). Like agricultural waste, cellulose is also one of the abundant renewable material available to substitute for fossil-fuel plastic. As a result, it was decided that the levels of the bioplastic attribute had to be the 'tree cellulose' and 'agricultural waste'.

The disposal options attribute plays an important role to understand how consumers prefer to discard bioplastic. Even if bioplastic requires a different recycling facility than conventional plastic, it is often marketed as recyclable, and its recycle by-product can be reused to make another product in the market (Soroudi & Jakubowicz, 2013). Moreover, because bioplastic is derived from biomass, it is biodegradable and compostable in nature, particularly fully bio-based plastic. Biodegradability is the inherent ability of a material to decompose under microbiological activity into naturally occurring substances such as carbon dioxide and water (Andrady, 2015; Sagnelli et al., 2017). Bioplastic is also compostable as it is produced by the all-natural plant-based raw material that can be naturally decomposed into carbon dioxide, water and compost (Balaguer et al., 2015). These methods of disposal are believed to hold the greatest potential for economic and environmental benefits compared to conventional plastic (CEBR, 2015). Thus, according to the literature on how to reprocess and dispose of bioplastic, the following three levels were set for this attribute: 'recyclable', 'compostable' and 'biodegradable'.

The certification label was included in the choice experiment because this is an important aspect that consumer would seek when buying a product. For example, the Forest Stewardship Council for paper-based is a certification label that communicates consumers a trusted source of packaging material. Certification labels ensure consumers that they are buying a sustainable and responsible product to the environment. Thus, for this attribute, the 'yes' and 'no' levels were included in the choice experiment design.

Price of the bioplastic milk packaging is a fundamental attribute for all designs because respondents have to trade-off a bundle of attributes against monetary values when making a purchasing decision. Unfortunately, little is known about the price of bioplastic product in the UK, and thus the levels of these attributes are based on

qualitative findings. Furthermore, a study on the implementation of the bio-based grocery bag in Italy reported that an extra charge between one and three euro cents (Povoledo, 2018). Thus, because the bioplastic application in the UK is still at an early stage, it was decided to prompt participants with the following five levels of price increase in percentage terms: 5%, 10%, 20%, 40%, and 80%. A market scenario explaining the eco-friendly packaging and choice tasks invited respondents to link these percentages to the price that they stated for the milk that they usually buy.

4.3.3.3 The experimental design of the innovative bioplastic packaging

A choice experiment is like a science experiment where attribute and attribute levels are combined to create hypothetical products (Louviere, Hensher & Swait, 2000). In this study, new milk packaging products or profiles were generated, developing a choice experiment design obtained using NGENE version 2017. A full factorial design consists of all possible combinations of attribute and attribute levels that can be presented to respondents and it ensures that these profiles are independent each other (Louviere, Hensher & Swait, 2000). If a full factorial design had been developed for this study, respondents would have been asked to evaluate 60 different profiles. The total number of profiles was obtained in the following way:

$$\begin{array}{l}
 2 \text{ attributes at 2 levels} \quad = 2^2 = 4 \\
 1 \text{ attribute at 3 levels} \quad = 3^1 = 3 \\
 1 \text{ attribute at 5 levels} \quad = 5^1 = 5 \\
 \text{Total number of alternatives} = 4 \times 3 \times 5 = \mathbf{60 \text{ profiles}}
 \end{array}$$

However, it is impossible to present all combination of profiles to respondents because of the enormous cognitive effort and a huge commitment of respondent, which will impact negatively on the validity and reliability of the choice experiment results. More practically, the literature suggests that a respondent should be presented with no more than 16 profiles to refrain from exhaustion (Bateman et al., 2002). But, which of all possible profiles should a researcher choose to capture the main effects of each attribute level?

Such a problem can be reduced by using a fractional factorial design, where a subset of the full factorial profiles is selected randomly so that specific effects of interest can be estimated efficiently (Louviere, Hensher & Swait, 2000). A well-known fractional design that has been applied in many studies is the orthogonal design. In order to achieve the statistical robustness of a full factorial design, orthogonal designs aim to

minimise the correlation between attribute levels in each profile. It said to be orthogonal if it satisfies attribute levels balance, and all other attributes are independent with one another (Hensher, Rose & Greene, 2015). Attribute levels balance also means that each attribute appears in an equal number of times in the particular subset profiles chosen.

An orthogonal design sometimes needs more than 16 profiles as suggested above, merely because an orthogonal design might not exist or unknown for just 16 profiles. Moreover, when an orthogonal design is identified, this may be still too large to handle by respondents. This problem can be solved by an option called blocking design which is obtained splitting the orthogonal design into smaller blocks, where each block is not orthogonal, but the combination of all blocks remains orthogonal (Hensher, Rose & Greene, 2015). This ensures that the choice model does not suffer from multicollinearity, and the variance between estimate parameters of the model is minimised. However, another important aspect of fractional design is the prevention of dominance design. D-efficiency designs with a minimal error called D-optimal designs are another experimental option for researchers to develop a fractional design which reduces this problem. As well as avoiding dominance profile, D-error designs aim to generated parameter estimates with standard error that are as small as a possible, i.e. efficient designs having a sufficiently low D-error (Bliemer & Rose, 2005).

Thus, in this study to produce a valid and effective choice experiment design, an initial fractional D-optimal blocking design was generated using the software NGENE version 2017. The final design contained 12 profiles, which were divided into two blocks, as shown in Table 4.8. Each block contained six choice sets were respondents had two choose between combinations of two profiles of bioplastic milk packaging and the status quo option.

Table 4.8: Profiles and blocks of the initial fractional orthogonal D-optimal design

Choice situations	Attributes			
	Block 1			
	Bioplastic	Label	Disposal option	Price
1	Tree cellulose	Yes	Compostable	5%
	Agricultural waste	No	Recyclable	5%
2	Tree cellulose	No	Compostable	5%
	Agricultural waste	Yes	Biodegradable	5%
3	Tree cellulose	No	Recyclable	80%
	Agricultural waste	Yes	Compostable	80%
4	Agricultural waste	Yes	Recyclable	40%
	Tree cellulose	No	Biodegradable	40%
5	Agricultural waste	No	Compostable	20%
	Tree cellulose	Yes	Recyclable	20%
6	Agricultural waste	Yes	Recyclable	10%
	Tree cellulose	No	Compostable	10%
Block 2				
7	Agricultural waste	No	Biodegradable	10%
	Tree cellulose	Yes	Compostable	10%
8	Tree cellulose	No	Biodegradable	80%
	Agricultural waste	Yes	Compostable	80%
9	Agricultural waste	No	Compostable	20%
	Tree cellulose	Yes	Biodegradable	20%
10	Tree cellulose	Yes	Recyclable	10%
	Agricultural waste	No	Biodegradable	10%
11	Agricultural waste	Yes	Biodegradable	5%
	Tree cellulose	No	Recyclable	5%
12	Tree cellulose	Yes	Biodegradable	40%
	Agricultural waste	No	Recyclable	40%

Following rules of validity and reliability of choice experiment designs, this initial design was piloted to simulate choice situations and to enhance both the design and model estimates before actual data collection. Further details of the pilot study will be explained later in this chapter in section 4.7.

4.3.3.4 The bioplastic packaging market scenario

Before showing the different choice sets identified with the choice experiment, respondents were provided with a market scenario which consisted of an initial, central and final part. The initial part of the market scenario invited respondents to reflect on the attributes and relative levels that they had to evaluate when making their choices for innovative eco-friendly hypothetical products. The initial part contained the following information:

Now imagine that you are standing in front of the supermarket shelf where next to the fresh milk that “you usually buy” there is also fresh milk packaged with bioplastic. Because bioplastic can have different characteristics, we would like you to evaluate different types of bioplastic packaging with respect to the following characteristics: sources of bioplastic, disposal options, certification and price. If you are not happy about information regarding these characteristics, please go back to the previous page and carefully read the given information again.

The central part explained respondents the choice tasks pointing out that the eco-friendly packaging does not affect the quality of milk that they usual buy. Respondents were asked to choose a discrete choice between ‘Milk A’, ‘Milk B’ and ‘my usual milk packaging,’ i.e. the status quo. The status quo is an important aspect of choice experiments because respondents are often asked to respond to several repeated choice sets and task complexity can give origin to learning and fatigue (Bradley & Daly, 1994; Johnson & Desvousges, 1997). In such a context, choice consistency and welfare estimates that emerge from choice experiments can be criticised because consumers may not fully process the information contained in choice sets (Simon, 1955; Heiner, 1983; Simonson and Tversky, 1992). As a result, the status quo option offers researchers the possibility to reduce the bias of welfare estimates allowing respondents the chance to give up the choice task (DeShazo & Fermo, 2002). The central part of the market scenario contained the following information completed by an example of a choice task (Figure 4.4):

Below you can see an example of a typical choice card that will show you the tasks that you have to undertake to evaluate this innovative bioplastic packaging. Each choice card consists of three options: “Milk A”, “Milk B” and “My usual milk packaging”. Milk A and Milk B show different combinations of the above-mentioned characteristics that bioplastic milk packaging might have, but in terms of food quality this milk is the same as the milk that you usually buy. The third option refers to the milk that you usually buy in terms of quality and packaging.

Which option of milk packaging do you prefer?

MILK A	
Bioplastic	Tree cellulose
Disposal type	Biodegradable
Bioplastic certified label on package	No
Price	80% more than I usual pay

MILK B	
Bioplastic	Agricultural waste
Disposal type	Compostable
Bioplastic certified label on package	Yes
Price	40% more than I usual pay

MY USUAL MILK PACKAGING	
	

Figure 4.4: An example of a choice set

As shown in Figure 4.4, each profile of a choice set contained a picture of a milk bottle of one litre having default characteristics such as a handle for ergonomics, a cap for maintaining hygienic conditions at standard level and a squared-long milk carton shape. Then respondents were asked to state their preferences between a pair-wise comparison of bioplastic fresh milk packaging and the status-quo option.

The final part of the market scenario raised participants' attention towards the six choice sets reminding them that buying eco-friendly packaging they will have less money for other goods and services.

Now we would like you to pay attention to the following six choice tasks which illustrate different choice situations of innovative bioplastic packaging that you might evaluate when shopping for fresh milk. We would like you to consider each of the six choice situations separately from the others, as if you were making

shopping choices on different days. Please make your six choices but before answering. Remember that your budget is limited and so spending more for this innovative milk packaging you will have less money to buy other goods and services.

4.3.3.5 Elicitation of attribute cut-offs of the compensatory model

In traditional compensatory RUMs, it has often assumed that consumers consider all the product's attributes presented to them and all of those that somehow affect their choices (Martin-Lopez, Montes, & Benayas, 2007; Kaye-Blake, Abell & Zellman, 2009; Garcia-Llorente, Martin-Lopez, & Montes, 2011). However, previous research suggests that it is fundamental to gain insights into the consumer's decision process because consumers often process many product attributes which require them to make decision simultaneously (Payne, Bettman & Johnson, 1992). They might have their own rules and thus making the decision process easier or less demanding for every type of product (Ding, Veeman & Adamowicz, 2012). For example, a vegetarian consumer will always seek for a food product that has a vegetarian symbol and ignore other attributes. Thus, by searching for the vegetarian symbol, the consumer will save time and make the choice process more efficient, even though they might spend money on undesirable attributes of the product. Moreover, consumers also generally try to improve the quality of their decisions, limiting the efforts to choose a product every time they make a decision (Lynch & Ariely, 2000). In Ding, Veeman and Adamowicz (2012), it was argued that consumers have cognitive limits to process all the product information and often used a heuristic-rule to ease their decision as written by Simon (1955) and Tversky and Kahneman (1974).

In discrete choice modelling, this problem is known as attribute cut-off in non-compensatory models and identifies a choice situation where a person sets the acceptable minimum level for an attribute when making her choices (Huber & Klein, 1991). Few examples of heuristic-rules involve the use of attribute cut-offs such lexicographic rules (Hauser, Ding & Gaskin, 2009), elimination-by-aspects (EBA) (Tversky, 1972) and conjunctive decision rules (Elrod, Johnson & White, 2004). In attribute cut-off, consumers exclude alternatives that do not reach an acceptable requirement level of the screening process and then choose only from the remaining alternatives in the choice set (Huber & Klein, 1991). For example, beverages such as milk and juices always come with packaging, and it is likely that some of the packaging attributes are unwanted by consumers due to questions of sustainability (e.g. unrecyclable material). In order to solve this problem, some scholars propose to

incorporate the attribute cut-offs violations in the conventional compensatory utility model (Ding, Veeman & Adamowicz, 2012; Aizaki et al., 2012; Swait, 2001). Ignoring the attribute cut-off violations (non-compensatory component) in the utility model can give significant errors of WTP estimates (Cantillo, Heydecker, & Ortuzar, 2006; Kaye-Blake, Abell & Zellman, 2009). Therefore, consumers do not achieve fully utility maximisation, and choice prediction may become ineffective in the representation of consumer's portion of the utility function.

Swait (2001) proposed the idea of attribute cut-off in the choice model to capture the psychological aspects and the actual utility maximisation of the consumer. In his study, he assumed that consumers do not consider all attributes and introduced a penalty utility function (attribute cut-off) in the RUM to examine the cognitive and WTP parts simultaneously. He found that the model diminished the extreme marginal effect on utility by improving the estimation of attribute values, as well as cut-off information, helped to explain observed consumer behaviour in choice situations. Therefore, by implementing attribute cut-off into the utility model is believed to deliver less biased estimations of WTP and at the same time a better understanding of how consumer value each attribute of product processes (Ding, Veeman & Adamowicz, 2012; Aizaki et al., 2012; Swait, 2001).

Because for food producers and retailers is paramount to understand how many attributes consumers consider when they make their choices, and what attribute is the most important to them, also in the study the choice experiment include attribute cut-off points. This approach has been applied in several studies (Aizaki et al., 2012; Ding, Veeman & Adamowicz, 2012; Moser & Raffaelli, 2014), which show that when cut-off violations values are considered models' estimations improve in terms of better utility choice models, less biased estimations, and rigorous information of salient attributes of the product under investigation.

Following the same approach, attribute cut-off was elicited after the choice market scenario inserting for each attribute a question where respondents had to state whether they would have purchased the good only for one of the attribute levels. For example, the cut-off attribute question for the bioplastic attribute was the following:

“When purchasing a Litre of fresh milk in bioplastic packaging, which of the following statements best represent your purchase decisions?”

- a. I only purchase bioplastic from tree cellulose*
- b. I only purchase bioplastic from agricultural waste*
- c. I do not care*

When a cut-off attribute violation is observed, the utility maximisation of respondents will face a penalty, as explained in the econometric modelling of the proposed discrete choice model.

4.3.4 Elicitation of WTP for food products marketed with eco-friendly packaging

The scope of this section was to elicit participants' willingness to buy and WTP for innovative eco-friendly packaging applied to their basket of food products. Contingent valuation (CV) is another popular stated preference method that has been applied in marketing and economic studies. Instead of choosing between product alternatives, CV is a stated preference method used to test the economic value of a good without a market (e.g. bioplastic milk packaging) where respondents are asked to state the maximum amount of money that they are willing to pay for a certain good or service (Bateman et al., 2002). CV aims to elicit an individual's preference in monetary terms for changes in the quality of non-market goods or services from the total expenditure. Individual's maximum WTP and willingness to accept the change will be uncovered by this expression in monetary terms simultaneously (Mitchell & Carson, 1989). Generally, in marketing research, this technique is used to test the worth of developing a new product, where a survey is administered to potential customers who are asked whether they intend to buy a product with certain characteristics and at a certain price.

Best practice of CV questions should be designed to get respondents to think seriously about the bioplastic packaging by providing them with the necessary information to make well-informed decisions and to encourage them to identify and reveal their monetary valuations. There are several methods for eliciting WTP such as open-ended direct formats, bidding games, payment cards, one and a half-bound dichotomous choice and randomised card sorting procedures. For example, in the double-bounded dichotomous choice format respondents state WTP in two rounds of bidding where the second WTP answer is conditional on the first stated WTP (Yes-No). This method has shown to generate more efficient estimates than those based on a single question (Hanemann, Loomis & Kanninen, 1991). The single question format is generally preferred to the open-ended question about WTP where respondents can express freely the maximum amount that they are willing to pay. Previous studies found that people commonly gave "protest answers" to open-ended questions, responding with zeros or extremely high values (Haab & McConnell, 2002). All these methods present a series of drawbacks such as cognitive tasks, large non-response rates, outliers, starting bias, 'yea-saying' and so on, but discussing in detail these elicitation payments techniques is beyond the scope of this thesis.

In this study, the CV elicitation method chosen to estimate WTP for the payment card. The payment card elicits WTP by asking respondents to select their maximum WTP amount from a list of sums presented on a card (Bateman et al., 2002). The payment card avoids the starting point bias of other iterative bidding approaches. However, a bias of payment card might arise with the range of prices used in the card, and the location of these prices shown in the card. In this study, respondents were asked to state the maximum amount that they were willing to pay in percentage terms on their stated weekly food expenditure if they had to buy their food products marketed with bioplastic packaging obtained from agricultural waste. In this case, the focus was only on WTP for this type of bioplastic because of the excessive agricultural by-product produced from that sector in the UK. As a result, respondents were provided with the following initial market scenario:

Despite the fact that bioplastic food packaging obtained from agricultural waste is one of the best sustainable alternatives to protect the environment using renewable resources, the new processing techniques that have to be fine-tuned and put in place to produce, this sustainable bio-plastic packaging might increase the final price of food products. Because of this, we would like you to imagine that you are shopping at your favourite retailer and most of the food products that you buy are marketed with bioplastic packaging obtained from agricultural waste. Would you be willing to buy your food products marketed with bioplastic obtained from agricultural waste?

The intention to buy question is standard practice for the CV method because respondents who state 'no' might be assumed to bid zero WTP. In order to investigate this aspect, CV surveys explore the reasons for choosing 'no'. This was also the case of this study, as shown in Figure 4.5. When respondents answered the 'd option' they were classified as true zero bidders because they did not value the proposed innovative packaging. Instead for the other reasons (a, b, c and e), they were classified as protesters because they objected to paying the extra money for the new packaging and thus they were excluded from the estimation of the willingness to pay. This question also included an open-ended answer to give a chance to respondents to state different reasons.

<p>If No. Why?</p> <ul style="list-style-type: none"> a) I need more information about bioplastic to answer the question. b) I do not want to pay more for bioplastic packaging. c) I am already paying enough for other sustainable products. d) I cannot afford to pay more for bioplastic obtained from agricultural waste. e) Bio-plastic packaging obtained from agricultural waste should be used to market all food products at no-extra-costs. f) Other reason: Please specify: _____

Figure 4.5: Reasons to refuse to buy food product marketed with bioplastic from agricultural waste

When respondents stated 'yes' they were automatically directed by QUALTRICS software to the remaining part of the payment card market scenario:

Now we would like you to think carefully about your weekly expenditure for food and the possibility of buying your food items with bio-plastic obtained only from agricultural waste. Because this change is likely to increase your food weekly expenditure we would like to know the maximum amount in terms of percentage (%) that you would be willing to pay to contribute to the reduction of agricultural waste and a better environment by buying food products packaged with this innovative type of bioplastic. Below there is a list of percentage increases which will affect your weekly expenditure for food £_____ that you stated previously. Please look at this list of percentages and indicate the MAXIMUM amount that you are willing to pay.

Before indicating the MAXIMUM increase that you are willing to pay please bear in mind that spending more for this sustainable packaging will not affect the quality of your food (i.e. food remains the same as before) and that you will have less available income for other goods and services.

The payment card was presented with a visual aid, showing percentage increases of their stated food weekly expenditure. Table 4.9 shows the 12 exponential percentage increases ranging from 1% and to more than 50%. When respondents selected a certain percentage, a script created in QUALTRICS prompted them with the exact monetary increases that they were willing to pay. For example, if a respondent selected 20% from the payment card and stated that s/he had previously spent £200 for his/her weekly food expenditure, s/he would have visualised a maximum WTP of £40 on the screen.

Table 4.9: Payment card

The amount you are willing to pay?
1%
2%
4%
8%
10%
15%
20%
25%
30%
40%
50%
More than 50%. Please specify:

4.4 Statistical and econometric analysis

This section explains the statistical modelling of psychological constructs of the VBN model and econometric modelling of WTP for innovative eco-friendly packaging.

4.4.1 Statistical modelling of VBN constructs

In behavioural science, VBN constructs are the latent variables represented by items which are believed to measure the model elements. Thus, taking into account the conceptual framework of this study (Figure 4.1), it is important to assess the VBN constructs evaluating how the underlying elements of the proposed model fit with the data collected. Deciding upon the significant latent variables that best represent the outcome of the proposed model (WTP for eco-friendly packaging), structural equation modelling (SEM) with path analysis provides an efficient and convenient way to describing the latent structures of an underlying set of observed variables which contains several statements. As shown in Figure 4.1, pro-environmental behaviour is captured via WTP of eco-friendly packaging, which is the outcome of a hierarchical psychological process that goes from ecological values to personal norms.

SEM is a multivariate statistical technique that takes a confirmatory approach to the analysis of structural theories and is a combination of factor analysis and multiple regression analysis. SEM conveys two important aspects: 1) investigates the causal processes by a series of structural equations, and 2) models the relationships between variables pictorially in order to enable researchers clearer conceptualisation of the theory (Byrne, 2010). SEM is used to analyse the structural relationship between observed variables and latent elements in order to find out the correlations between

the variables simultaneously. Given the hierarchical nature of the proposed VBN conceptual framework, SEM ideally seems to be an appropriate statistical technique capable of confirming the ability of the model to understand respondents' WTP. SEM can also determine the adequate goodness of fit of the environmental elements to this study, which will be used in the subsequent econometric analysis as illustrated in the next section. Moreover, rather than investigating general attitudes about environmental issues through proxy questions of every element, this research seeks to identify the underlying dimensions that drive respondents to act pro-environmentally spending more on bioplastic packaging in the UK.

A general SEM model is decomposed into two sub-models i.e. the measurement model and structural model. The measurement model defines the relationship between a latent variable with its observed variables' score and the covariance among the latent variables. This model is also known as confirmatory factor analysis. On the other hand, the structural model defines the relationships between latent variables only (Byrne, 2010). Figure 4.6 exhibited an example of the AC and AR latent variables to show the differences between the two submodels.

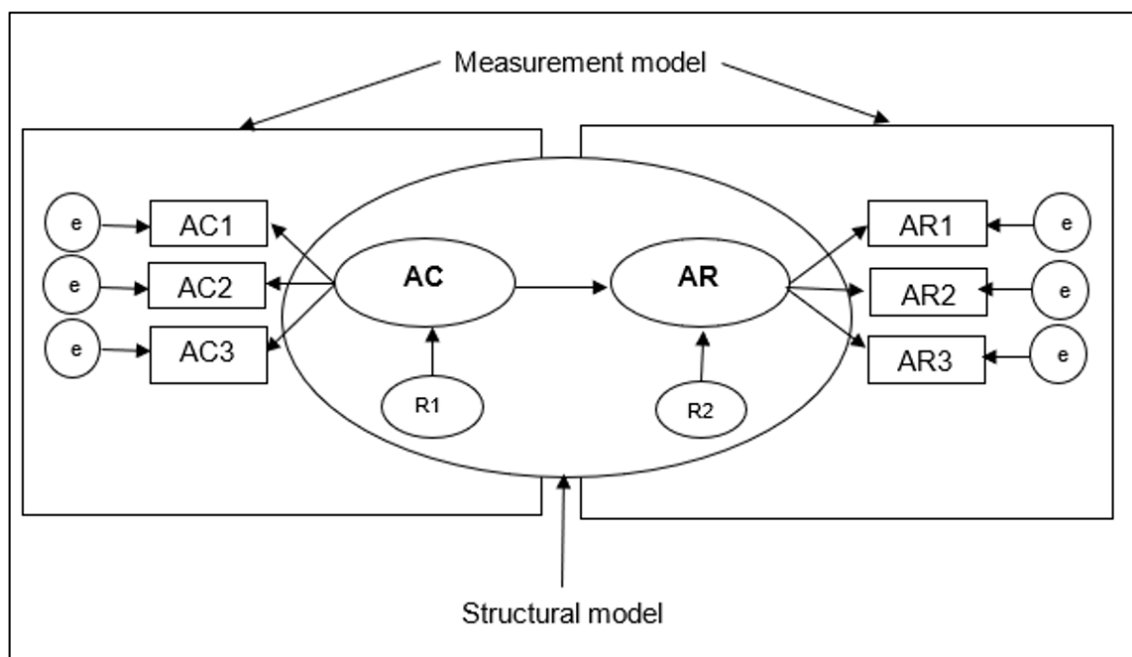

Figure 4.6: A general structural equation model defined into measurement and structural model (Source: Byrne (2010))

In SEM, every regression path is symbolised by a single-headed arrow pointing from the variable of influence to the variable of interest as in the conceptual framework of the study. The observed items of latent variables are represented in the square and associated with error terms (e), while only endogenous latent variables (NEP, AC, AR, PN) are represented by ovals and associated with residual terms (R). The measurement model captured all the VBN latent variables via respondents' score of the items that contribute to the identification of each construct. The structural model examines only the relationships of latent variables towards WTP for eco-friendly food packaging, i.e. the proportion of money that respondents are willing to pay from their weekly food expenditure to purchase food products marketed with bioplastic packaging. The equation-like representations of the estimated linear dependencies for the measurement and structural model are as follows:

Measurement model:

$$\text{BIO} = 4 \text{ Biospheric items} + 4 \text{ errors}$$

$$\text{ALT} = 4 \text{ Altruistic items} + 4 \text{ errors}$$

$$\text{EGO} = 4 \text{ Egoistic items} + 4 \text{ errors}$$

$$\text{NEP} = 15 \text{ NEP items} + 15 \text{ errors}$$

$$\text{AC} = 9 \text{ AC items} + 9 \text{ errors}$$

$$\text{AR} = 9 \text{ AR items} + 9 \text{ errors}$$

$$\text{PN} = 9 \text{ PN items} + 9 \text{ errors}$$

Structural model:

$$\text{WTP} = \text{BIO} + \text{ALT} + \text{EGO} + (\text{NEP} + \text{resid1}) + (\text{AC} + \text{resid2}) + (\text{AR} + \text{resid3}) + (\text{PN} + \text{resid4})$$

As the statistical analysis of confirmatory SEM implies hypothesis-testing of the structural model. In the proposed model for this study, Figure 4.7 below showed all the hypotheses specified from the original model by Stern (2000). The primary task before running the econometric analysis is to define the goodness-of-fit of the hypothesised model and the sample data. This is because the VBN model might be classified differently with the different context of the study. For example, ecological values of biospheric contributed the most towards NEP in WTP premium price of green products study (Ziaei-Bideh & Namakshenas-Jahromi, 2014); while altruistic value was contributed the most in WTP of energy conservation study in Tunisia (Ibtissem, 2010). Therefore, the following hypotheses were tested performing an SEM analysis:

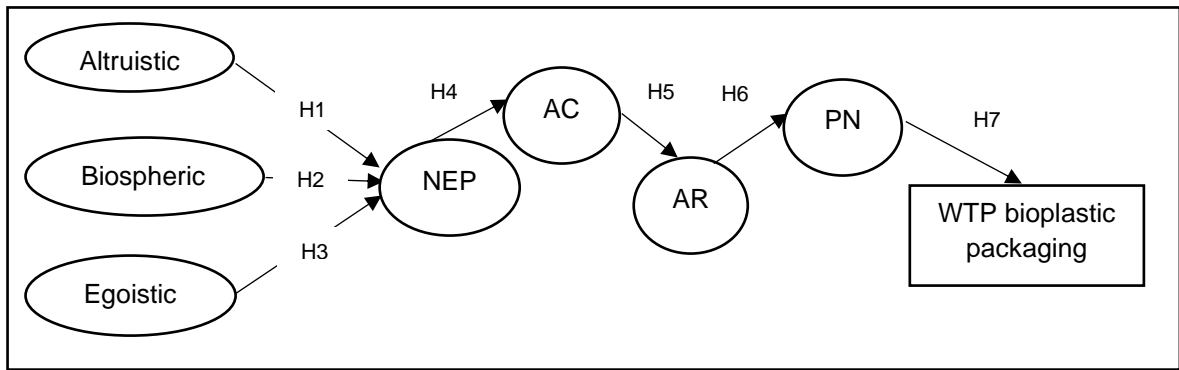

Figure 4.7: Conceptual model with the hypothesis

- H1:** *The altruistic value has a significant positive effect on the overall view of the consumers towards the environment (NEP).*
- H2:** *The biospheric value has a significant positive effect on the overall view of consumers towards the environment (NEP).*
- H3:** *The egoistic value has a significant negative effect on the overall view of the consumers towards the environment (NEP).*
- H4:** *Consumer's overall view of the environment (NEP) has a significant effect on the awareness of the environmental consequences (AC).*
- H5:** *Consumer's awareness of the environmental consequences has a significant effect on the responsibility towards the environment (AR).*
- H6:** *Consumer's ascription of responsibility to the environment has a significant effect on personal norms (PN).*
- H7:** *Personal norms have a significant effect on consumers' willingness to pay for sustainable food packaging.*

The core focus of the current SEM analysis was to locate the source of a misfit in the proposed model and thus to determine a model that better describes the sample data. According to Joreskog (1993), the ultimate objective of SEM is to find a model that is both substantively meaningful and statistically well fitting. As a result, data analysis will evaluate every regression path analysis simultaneously and will generate the regression coefficients that indicate the source of misspecification and modification indices. Modification indices are a possible approach to find the best fit model. Moreover, four goodness-of-fit indices (RMSEA, CFI, TLI and GFI) will be evaluated to determine the best-fit model.

The root mean square error of approximation (RMSEA) evaluates how close the model fits the data. Value of this index below 0.06 indicates a good fit model, i.e. the lower the value, the better the fit of the model (Hu & Bentler, 1999). The comparative fit index (CFI) instead compares the existing model fit with a null or independent model where

the latent variables are assumed to be uncorrelated with the observed items. Hu and Bentler (1999) suggest that values of the CFI of 0.9 or greater are indicative of a good model. Like CFI, Tucker-Lewis index (TLI) reflects the proportion by which the specified model fits the data compared to the null model. Lastly, the goodness of fit (GFI) is the proportion of variance accounted for the estimated population covariance (Tabachnick & Fidell, 2007). Both TLI and GFI are recommended to score 0.9 or above to assume a better model. In this study, besides to find the fit VBN-adopted model, the most influence latent variables can be determined through this SEM approach. The result of SEM analysis will be used as input for the econometric analysis explained in the next chapter.

4.4.2 Econometric modelling of WTP elicited via the choice experiment

As explained previously, CEs are rooted in Lancaster theory (Lancaster, 1966) and the fundamental econometric approach to assessing consumer preferences within a discrete choice multi-dimensional environment is via RUMs. Furthermore, RUMs with the compensatory and non-compensatory approach are expected to recognise the actual utility maximisation of buying innovative bioplastic sustainable packaging. The RUM states that an individual utility (U_{ni}) can be represented into a systematic component (V_{ni}) of good's attributes, cut-offs attributes, individual characteristics and a stochastic component (ε_{ni}) of unobserved factors by the CE (McFadden, 1974). This can be written as:

$$U_{ni} = V_{ni} + \varepsilon_{ni} \quad (1)$$

where n indicates respondent, and i is the alternative chosen of a choice situation. Assuming the ε_{ni} is independent and identically distributed random variable (IID) and has extreme value Gumbel distributed, the conditional logit model is obtained. Conditional logit models are commonly used as a form of the discrete choice model in consumer behaviour studies, besides the multinomial model. However, previous literature shows that the conditional logit model has some drawback (Train, 2009). This model represents systematic taste variations and is unable to address heterogeneity in consumer's preferences. Moreover, it assumes independence of irrelevant alternatives (IIA) with restricted alternatives substitutions, and also independence of unobserved factors where there is a possibility that factors are correlated. In order to tackle these drawbacks, previous studies suggest a more flexible model, i.e. mixed logit model (ML) also known as Random Parameter Logit. This model shows full relaxation of the IID assumption, accommodates correlations among observations and is accountable for

uncontrolled heterogeneity in taste variations among consumers (Forbes-Brown et al., 2016) and generate better estimates. The ML equation could be written as:

$$U_{ni} = \beta'_n X_{ni} + \eta'_n X_{ni} + \varepsilon_{ni} \quad (2)$$

where β_n is the vector of expected coefficients for packaging attributes, η_n is the vector of expected coefficients of individual-specific deviations from β_n , X_{ni} is the vector of attributes levels of alternative packaging (i), and ε_{ni} is the random error. The random error has an extreme value Gumbel distribution with variance given by $\mu^2_n (\pi^2/6)$, where μ^2_n is an individual specific scale parameter normalised to 1. This shows that each consumer has a specific value of each parameter in the (2).

ML is derived from the integral of the conditional logit model where the probability of integral of choice sequences over parameter density functions allows randomness in the model. The probability of consumer n choosing the observed sequence of choice situation T is the integral of the chosen packaging of logit probability over all possible values of β_n (Train, 2009):

$$\text{Ln} (\beta_n) = \frac{e^{\beta_n X_{ni}}}{\sum_j e^{\beta_n X_{nj}}} \quad (3)$$

$$P_{ni} = \int \prod_T (\text{Ln} (\beta_n) f (\beta, \sigma^2) d\beta \quad (4)$$

where i is the packaging alternative chosen in choice situation t with $f (\beta, \sigma^2)$ is the probability density function for the preference parameters consumer β_n with standard deviation σ . This model allows heterogeneity not to be linked with observed variables and accounted for flexible substitution patterns between alternatives in a choice situation. However, equation (4) is not a closed-form, but the solution is approximated by simulations, and it is necessary to assume the distribution of the β_n in the population via the estimation of choice model (Train, 2009).

Because consumers' WTP towards innovative sustainable food packaging is the main interest of this study, it is important to estimate the WTP of an individual for marginal improvements in every attribute studied. WTP is usually calculated by taking the ratio of non-monetary attributes expected coefficient by price coefficient. Train and Weeks (2005) show that WTP estimates can be estimated directly in ML specification by reformulating the model in such a way that estimated parameters represent the parameters of the WTP distribution rather than the parameters of the usual coefficients. This is called as estimation ML model in WTP space, rather than the

original approach. The advantage of this approach is to avoid the rather arbitrary choice of WTP distribution that arises from dividing the coefficients of the non-monetary attribute with cost attribute (Hole & Kolstad, 2012). Moreover, this ML framework in WTP-space allows for the randomness of scale values across consumers in the study, thereby overcoming the issue of interpersonal variance heterogeneity (Thiene & Scarpa, 2009).

To illustrate the utility specification in the WTP-space, the model proposed by Train and Weeks (2005) and adapted to this study is shown in equation (5) below

$$U_{Tni} = -\alpha_n P_{Tni} + \beta'_n X_{Tni} + \mathcal{E}_{Tni} \quad (5)$$

where n represent consumers choosing an alternative i in the choice situation T , α_n and β_n vary randomly over consumers, P_{Tni} is the vector of a special utility separable in cost or price, and X_{Tni} is the vector of non-monetary attributes and cut-offs variables.

To understand the circumstances under which the scale parameter can be expected to vary across consumers, α_n represents the marginal utility of money and β_n consumers' taste preferences coefficients for packaging attributes that vary because of personal taste differences across the population of dairy milk consumers in England. An extreme value Gumbel distributed error term is assumed with variance equal to μ_n^2 ($\pi^2/6$), where μ_n is the scale parameter for the consumer n . However, the error term, \mathcal{E}_{Tni} represents factors that are known by respondents and unknown by the researcher. Therefore, dividing equation (5) with a standard deviation of scale parameter, μ_n , it will be possible to capture the randomness of each respondent and improve the taste heterogeneity in the utility model. This is because a respondent might be evaluating the same bioplastic packaging with others, but they might have different knowledge of environmental awareness and past experience with sustainable packaging (Thiene & Scarpa, 2009). Dividing equation (5) by the scale parameter μ_n , the following equation will be obtained:

$$U_{Tni} = -(\alpha_n / \mu_n) P_{Tni} + (\beta'_n / \mu_n) X_{Tni} + \mathcal{E}_{Tni} \quad (6)$$

where \mathcal{E}_{Tni} is IID extreme value with a constant variance of $\pi^2/6$. The scale parameter does not affect the behaviour yet resulting in the new error term that has the same variance for all participants. It is interesting to note that if the μ_n varies randomly, the utility coefficients are correlated since μ_n enters the denominator of each coefficient. Specifying the utility coefficients to be independent implicitly constraints the scale parameter to be constant. If the scale parameter varies and α_n and β_n are fixed, then

the utility coefficients vary with perfect correlation. If the utility coefficients have a correlation less than unity, then, α_n and β_n are necessarily varying in addition to, or instead of, the scale parameter, μ_n . The equation (6) is called the ML model in preference space and could be rewritten as:

$$\lambda_n = (\alpha_n / \mu_n) \text{ and } C_n = (\beta_n / \mu_n)$$

$$U_{nit} = - \lambda_n P_{Tni} + C_n' X_{Tni} + \varepsilon_{Tni} \quad (7)$$

The WTP estimation for an attribute is the ratio of the attribute's coefficient to the price coefficient: $W_n = C_n / \lambda_n$. Train and Weeks (2005) directly estimated WTP into the specified model re-parametrised, where W_n is the vector of marginal WTP parameters, λ_n is the cost attribute coefficient divided by scale parameter, and ε_{Tni} is the extreme value Gumbel distribution with variance $\pi^2/6$. This equation is called a utility in WTP space.

$$U_{nit} = - \lambda_n P_{Tni} + (\lambda_n W_n)' X_{Tni} + \varepsilon_{Tni} \quad (8)$$

When model ML in WTP-space is approximated by maximum likelihood simulations, the ratio between non-monetary and price attributes distributions may lead to the unrealistic large variance of WTP among the consumers (Thiene & Scarpa, 2009) when a specific packaging due to use of random coefficient models such as ML to predict taste heterogeneity of WTP. However, by having an inverse moment in the simulations for all distributions can assure the WTP distribution has infinite moments. It can be done by setting bound to prevent from non-zero density around zero (Daly, Hess & Train, 2012). In order to avoid unlikely large variance of the WTP estimations in ML, the utility model re-parameterised in such a way that the WTP estimation is directly estimated into the specified model as shown in equation (8).

Even though this method is rather scant, it seems promising to assess more persistent prediction of the WTP of innovative bioplastic as a new sustainable packaging material because it tolerates consumers taste heterogeneity and personal preferences. Thus, a ML model estimating WTP-space with all attributes assumed to be normally distributed was performed using Stata SE 15. The adoption of this model is useful to examine the most influential attributes of sustainable milk packaging and the maximum satisfaction when choosing this packaging.

4.4.3 WTP econometric modelling of CV

In many studies conducted in the past, the research used to estimate WTP elicited with payment cards or other selected elicitation methods performing ordinary least square estimations (Bergstrom, Dillman & Stroll, 1985). However, when monetary values of WTP are censored (no values below £0 observed) like in this study, least squares estimation yields biased and inconsistent parameter estimates (Maddala, 1983). When dealing with non-linear regression models like this, some studies simply drop zero bids from the dataset. However, such an approach would lead into a sample selection bias eliminating potentially useful information from the data set. In order to counteract this problem, a maximum likelihood estimation via Tobit regression model can be performed to achieve not only unbiased and consistent parameter estimates, but also allow researchers to include zero bids and thus more information in regression analysis (Tobin, 1958).

As a result, also in this study, a Tobit analysis was performed to estimate WTP for weekly expenditure increases of respondents' food basket marketed with bioplastic obtained from agricultural waste. To specify the Tobit model for this study, suppose that an individual has a latent (unobserved) demand for this bioplastic packaging, denoted as Y^* . Y^* is not expressed as a purchase until some known constant threshold (L), is passed only when the observed Y^* is greater than L (Cameron & Trivedi, 2010). At this point, the zero expenditure can be interpreted as a left-censored variable that equals zero when $Y^* < L$. In this study, the zero WTP is a censored observation. Thus, all respondents who were willing to buy food products marketed with eco-friendly packaging and those who could be assigned a true zero answer of the 'no' reason options were included in the Tobit analysis. On the other hand, respondents who chose protest answers were discarded from the analysis.

In general, the Tobit model can be expressed as below.

$$Y^* = WTP^* = \begin{cases} B'X + e & \text{if } WTP > 0 \\ 0 & \text{otherwise} \end{cases} \quad (9)$$

where WTP^* was calculated by multiplying respondents' weekly expenditure by the stated increase in percentage terms. The Tobit regression model of interest is specified as an unobserved latent variable, Y^* also known as WTP^* in the below equation.

$$WTP_n^* = \sum \beta_n' X + e_n \quad (10)$$

where n is a respondent, β_n is the vector of expected regression coefficients, X is the vector of the explanatory variables (psychographic and economic characteristics of respondents), and e_n is the error term normally distributed with zero mean and finite variance, $N(0, \sigma^2)$ of respondent n . Three components of the explanatory variables were believed to impact on WTP: socio-demographic profiles of respondents (e.g. age, education, gender and household size), knowledge about bioplastic and psychological constructs of the VBN model. This is because someone who is concerned about environmental issues would probably want to spend more on this new sustainable packaging obtained from bioplastic material.

The estimation of the proposed censored regression Tobit model and post-estimations to predict how marginal changes in explanatory variables will affect WTP will be conducted using Stata SE 15. The following two marginal effects were estimated after regression analysis:

1. The changes in the unconditional expected value of WTP being uncensored:

$$(\partial E(y^* | x) / \partial x).$$

2. The changes in conditional expected value of WTP being truncated:

$$(\partial E(y | x, y > 0) / \partial x).$$

4.5 Target population, sample size and sampling strategy

The target population refers to people who can benefit from non-market innovative eco-friendly packaging in the UK. Since in this study the choice experiment was developed on milk and all consumers responsible for shopping might be interested in this innovation, the target population was selected using two filter questions which excluded respondents who did not have these characteristics. As mentioned earlier, the following two initial filter questions were prompted to respondents on the QUALTRICS website: '*are you responsible for your food shopping?*' and '*do you consume fresh milk?*'.

Given the target population identified for this study, the next step is to draw an appropriate sample that is representative of this population. Considering that a sample is a subset of the target population, it is important to understand how to save time and money when collecting data (Saunders, Lewis & Thornhill, 2007). Generally, the sample size for stated choices is generally small in comparison to other methods

because one observation per respondent produces several choices for the same research context (De Bekker-Grob et al., 2015). In this study, a respondent answering six choice cards will produce produced six observations instead of just one.

The sample must represent the entire population accurately and be sufficiently large to generate precise estimations of the psychological VBN model and WTP (Mitchell & Carson, 1989). The sample size can be determined by referring to a similar study, using a statistical formula or implementing a table published by Yamane (1967) (Israel, 1992). In this study, the Yamane published a table of sample size with 95% confidence level was chosen to determine the sample size. With more than 46 billion people in the UK population, a minimum of 400 respondents are enough to acquire a satisfactory sample of the target population. However, in order to compensate for any nonresponse observations, it was decided to draw a sample of 600 from the UK Internet population.

There are several types of probabilistic and non-probabilistic sampling methods. In probabilistic methods, every member of the target population has an equal opportunity to be selected. This method offers no bias towards any consumer groups of the population and the data collected is reliable to gain adequate information.

Non-probability sampling methods are techniques that select members of the target population in a non-random way, i.e. based on the subjective judgement of the researcher. Market surveys or case studies have widely used non-probability sampling techniques as it might not be possible to sample giving to every member of the population the same chance to be selected. In this study, it was decided to use non-probabilistic quota sampling that reflected the structure of the UK population (Saunders et al., 2007). This sampling is normally used for a very large population where probability sampling seems impossible to implement. But yet, each quota should enable to represent the population significantly, and the responses collected need to be sufficient to support statistical analyses planned to achieve stated objectives (Adler & Clark, 2011).

As in many studies, calculations of quotas were based on relevant and population data available from the national census (Saunders, Lewis & Thornhill, 2007). To get the quotas representing the UK population, the 2015 census data obtained from the Office for National Statistics was used. For example, for a final sample size of 600, if the census data show that in the UK, there were 48% male, the final sample size will contain 288 male respondents. Table 4.10 indicates how the quota sampling for gender and age were calculated by block taking into account the census data of the

UK population and the sample of each age and gender proposition. Both samples of block one and block two are made of 300 respondents and should be adequately representative of the UK internet population. According to the Internet World Stats (<https://www.internetworldstats.com>), in 2018, the penetration index of the UK population was nearly 95%, i.e. almost all the UK population have access to the Internet.

Table 4.10: Quota sampling of the UK population 2015

Gender	Age	Population	Sample composition		
			Quota percentage	Version 1	Version 2
Male	16 – 24	3,357,369	7.15	21	21
	25 – 34	3,935,293	8.39	25	25
	35 – 44	3,713,542	7.91	24	24
	45 – 54	4,017,466	8.56	26	26
	55 – 64	3,231,000	6.89	21	21
	65 – 74	2,714,169	5.78	17	17
	75 and more	1,972,420	4.20	13	13
		22,941,259	48.89	147	147
Female	16 – 24	3,201,095	6.82	20	20
	25 – 34	3,927,723	8.37	25	25
	35 – 44	3,754,387	8.00	24	24
	45 – 54	4,116,650	8.77	26	26
	55 – 64	3,334,140	7.11	21	21
	65 – 74	2,917,683	6.22	19	19
	75 and more	2,732,073	5.82	17	17
		23,983,751	51.11	153	153
Total		46,925,010	100.00	300	300

4.6 Data collection

In this study, the survey was administered electronically by QUALTRICS, developing an online survey supplied by the same company (<https://www.qualtrics.com>). All questions were completed by respondents with no interaction with the researcher (Adler & Clark, 2011). This internet-mediated questionnaire has many advantages and is increasing in popularity, especially in marketing studies. Until recently, creating and conducting research online was a time-consuming process and required high technical skills to be developed. Today, survey authoring software packages such as QUALTRICS or Survey Monkey or Google Form make online survey research much easier and faster than a few years ago (Wright, 2005).

One advantage of gathering data via online is the ability to provide access to groups of respondents from a great distance, which is difficult, if not impossible, to reach out through another channel (Garton, Haythornthwaite & Wellman, 1999; Wellman, 1997). The QUALTRICS team contacted potential members of the identified quota sampling. This was a particularly effective way to the distributed a questionnaire to a large number of respondents while keeping anonymous their responses. This is one of the advantages of web surveys, especially when there are groups of people who are sensitive to openly share their habits, beliefs and opinions towards a particular topic of study. By surveying online, it enables communication among those groups who may hesitate to meet face-to-face and technically generate less biased estimates.

Even though there are some ethical issues highlighted by the identification of the IP address and the location of respondents, QUALTRICS serves several technical options where all these ethical issues can be solved by qualified software tools with data protection certification. An agreement made with the company (Appendix 13) ensured that the confidentiality of respondents was guaranteed, and the survey data remained safe. Another challenging task in conducting this online survey was to obtain a sufficient response rate because potential respondents can easily delete the questionnaire invitations (Sue & Ritter, 2007). However, with follow-up after the invitation might help to increase the response rate. In this study, QUALTRICS ensured to meet the requested sampling frame shown in Table 4.10. The data collection process started after having obtained the ethical approval of the University of Reading. All issues mentioned above were addressed in the ethical application with an attachment to the questionnaire. The survey began in the mid of July 2018 and ended in October 2018. The first two months were dedicated to the piloting and fine tuning of the choice experiment.

4.7 The pilot study

A pilot study was conducted through online and paper-and-pencil survey around the University of Reading and its surrounding neighbourhood in July 2018 until early August 2018. The purpose of this test was to get direct feedback from respondents about the structure of the questionnaire, besides pre-testing the reliability and validity of the questionnaire in general. In particular, the pilot test was conducted to acquire information on the perceived time of answering a questionnaire, the difficulty of answering questions, the ability of questions to differentiate across respondents and to correct any other issues unforeseen by researchers.

For this purpose, the two versions of the questionnaire (block 1 and block 2) were equally distributed to colleagues, university staff, students and public. An anonymous link to the web-based questionnaire and 18 paper-and-pencil questionnaires were distributed via email and face-to-face interviews with students, local consumers and university staff. At the end of this piloting, 47 questionnaire resulted completed in all parts, while three were rejected as respondents did not consume dairy milk and were not responsible for household grocery. Some comments on behalf of respondents pointed out that some words were difficult to understand, and that the structure of the questionnaire could have been improved. Overall, the completion time of a questionnaire was about 20 to 25 minutes on average, which was what expected by the research team.

The analysis of the reliability and validity of the responses showed high variance in responses and that the Cronbach alpha of the VBN constructs was very good, i.e. 0.79 and above. In the light of these preliminary results, some improvement was applied in relation to the structure of the questions, grammatical mistakes and words used. More specifically, questions and information were simplified regarding the language used, and the length of the information sections, i.e. the market scenarios were re-structured and proofread.

Another important purpose of this pilot study was to generate prior values for fine-tuning D-optimal choice experimental design. Bliemer and Collins (2016) stated that in order to produce an efficient and robust experimental design, prior values are commonly obtained from a pilot study or own expert judgement. This is because if some information of attributes' parameters is available, then the design can be improved regarding the variance-covariance matrix in the possible choice situations. Because the initial choice design (Table 4.8) was produced with zero prior values other than for price whose prior value was -0.01 and in line with the sign shown in similar studies. Therefore, instead of assuming all the parameters are zero, generating prior values from the pilot study seems necessary to improve the choice designs to obtain persistence data at the end.

After having gained data from the pilot study, the significant beta coefficients were generated by ML estimation in STATA, and these coefficients were set as the prior values for all the attributes. There were - 4.16 for the price; 1.24 for both types of bioplastic packaging; 0.58 and 0.31 for three options of bioplastic disposal method; and lastly, 0.16 for the certification label. NGENE was used again to simulate the choice

situations shown in Table 4.11. The syntax for the choice design before and after the pilot study is attached in Appendix 15.

Table 4.11: Calibration of the orthogonal D-optimal design after the pilot study

Choice situations	Attributes			
	Block 1			
	Bioplastic	Label	Disposal option	Price
1	Tree cellulose	No	Biodegradable	80%
	Agricultural waste	Yes	Compostable	40%
2	Agricultural waste	Yes	Compostable	40%
	Tree cellulose	No	Recyclable	80%
3	Tree cellulose	Yes	Recyclable	20%
	Agricultural waste	No	Biodegradable	10%
4	Agricultural waste	No	Recyclable	5%
	Tree cellulose	Yes	Biodegradable	20%
5	Tree cellulose	No	Compostable	10%
	Agricultural waste	Yes	Recyclable	5%
6	Agricultural waste	Yes	Biodegradable	5%
	Tree cellulose	No	Compostable	10%
Block 2				
7	Agricultural waste	Yes	Recyclable	10%
	Tree cellulose	No	Biodegradable	20%
8	Agricultural waste	No	Compostable	40%
	Tree cellulose	Yes	Biodegradable	80%
9	Tree cellulose	Yes	Compostable	20%
	Agricultural waste	No	Recyclable	5%
10	Tree cellulose	Yes	Biodegradable	10%
	Agricultural waste	No	Compostable	10%
11	Tree cellulose	No	Recyclable	80%
	Agricultural waste	Yes	Compostable	5%
12	Agricultural waste	No	Biodegradable	5%
	Tree cellulose	Yes	Recyclable	40%

Table 4.11 visibly shows significant improvement compared to the pilot experimental design illustrated in Table 4.8. In particular, the frequency of the disposal options and price appeared in well-balanced amount than previously. For example, 'biodegradable' was presented six times in block two of the initial design, but after having improved the design with prior values, all the disposal options (biodegradable, compostable, recyclable) occurred equally four times in both blocks. Moreover, also for price levels, a more balanced situation was observed between the two blocks. The new choice sets generated by the piloting were included in the final questionnaire. Overall, the pilot study showed positive feedback and allowed the researcher to improve participants' comprehension of the final version of the questionnaire.

4.8 Summary

This chapter explained the methodological approach adopted by this study to inquire into details on how environmental values of an individual affected the pro-environmental purchasing behaviour of innovative sustainable packaging. In order to achieve stated objectives, an online survey was administered to a sample of the UK population. The final questionnaire contained five questions which aimed at eliciting information necessary to operationalise the proposed VBN conceptual framework. As well as explaining how information was collected, the chapter also explains statistical and econometric models used to achieve stated objectives. The chapter ended with the sampling design and the data gathering processes as well as results of the pilot study to test the reliability and validity of psychological constructs and the choice experiment design.

CHAPTER 5

RESULTS AND DISCUSSION

5.1 Introduction

This chapter represents the quantitative results as explained in the previous chapter. It is included in the respondents' composition, SEM and the economic models presented in detail. The chapter begins with the descriptive results of the collected data. As the psychological part of the study, the VBN proposed model had been tested through AMOS SEM. The approach acts as an exploratory factor analysis to observe the theoretical constructs that fit into the data and find the best latent variables to be used in the Tobit model analysis. Then, the ML estimation in the WTP space results are presented to explore the most preferred attributes of bioplastic packaging among respondents incorporating the cut-off violation variables. A further analysis of variance between the WTP and the sociodemographic was completed for the insightful outcome of the results, and latent class logit analysis to determine the identification of the consumer group. Lastly, the STATA Tobit regression analysis with two marginal effects was conducted to find out the factors that influence respondents' WTP more on bioplastic packaging.

5.2 Sociodemographic characteristics and shopping habits of the respondents

A total of 565 respondents participated in this study. Table 5.1 shows the sociodemographic profiles of the respondents. The distribution of the sample data corresponded to the current population in the UK, as stated in the Office for National Statistic report in 2015. Because of the quota sampling, all the socio-demographic profiles matched with the population, especially gender and age. However, sample of certain demographic profiles such as educational level and occupation were slightly differed from the National statistic as it based on the 2017 and 2018 database (Appendix 20). For example, only 33% of the UK population obtained high school educational level, however, the sample collected 63% of respondents. Similarly, with occupation group of 'skilled and services' sectors, population recorded that this group is the largest group of employment in the UK on 2017; but the sample collected only 23%. Besides the quota sampling only focusing on the two demographic profiles (e.g. age and gender), the situation may be happened because respondents cannot find an answer that accurately reflects their personal profiles. Moreover, respondents do not want to answer questions about the sensitive or personal to them as the QUALTRICS

website designed them to compulsorily answer all the questions to avoid missing values.

Out of 565 respondents, 60% of them were female, and 40% were males, where 37% of the respondents had a university or postgraduate degree, meanwhile, 63% of them were high school graduates or less. In terms of age groups, the largest age group was represented by respondents aged 35 to 54 years old (41%), followed by the youngest group (33%) and only 26% of the older respondents were aged 55 above in the sample. Furthermore, overall, 34% of the respondents came from the middle income class with their yearly incomes between £20,000 until £50,000, before tax deduction. However, 50% of the sample reported having income levels below £10,000 to a maximum of £20,000 yearly. The remaining respondents belonged to the high-income class (16%) with more than £50,000 yearly. Apart from household income, approximately 1/3 of the respondents are currently living with their partner with no children (36%), nearly 1/3 of them are single (25%), and the remaining 1/3 are families with children at home (39%). Lastly, about 1/4 of the respondents worked in managerial and administrative sectors (37%), while 23% worked in the skilled and services sectors such as machine operators and customer service. The remaining respondents are in retirement (15%), and 26% belonged to an unemployed group which included the full-time students and respondents who are seeking and not seeking for work.

Table 5.1: Respondent composition

Demographic profile	Frequency	%
Age		
18 – 34	188	33.3
35 – 54	230	40.7
55 and older	147	26.0
Gender		
Male	225	39.8
Female	340	60.2
Education		
High school or less	354	62.7
University degree or postgraduate	211	37.3
Household income		
Low income	283	50.1
Middle income	193	34.2
High income	89	15.8
Occupation		
Managerial and administrative	207	36.6
Skilled and services	128	22.7
Retired	83	14.7
Unemployed: students, job seeker, etc.	147	26.0

Family size		
Single	143	25.3
Couple, no children	203	35.9
Family with children	219	38.8

In terms of shopping habits, all respondents selected are dairy milk consumers as it was the prerequisite question to participate in this study in order to avoid sample bias at the beginning of the survey. Table 5.2 illustrates the weekly milk consumption of the respondents. Almost 1/2 of the respondents consumed between 2 to more than 3 pints on a weekly basis (45%) and 1/4 of them took more than 3 ½ pints (27%), and 29% of respondents consumed less than 2 pints of the dairy milk intakes per week. In terms of the milk category, most of the respondents chose semi-skimmed milk (60%), few of them picked skimmed milk or 1% fat milk (10%) and nearly 1/3 preferred whole milk, which is probably due to the dietary requirement of the household (31%). Dairy milk in the UK also provides consumers with several types where consumers have options to select the best milk suit to their dietary requirements and lifestyles. In the sample of this study, the respondents largely preferred to consume conventional types of milk available in most shops (85%) and the remaining respondents chose milk with organic or animal welfare accreditation or unprocessed farm milk (15%). Large supermarkets such as ASDA, M&S, Tesco or Sainsbury's were the favourite retailers for fresh milk (75%), while some of the respondents liked to shop for milk in local shops around their neighbourhood (18%), followed by other types of stores (8%) such as milkman delivery company, farmers' market or online supermarkets such as OCADO. Following that, more than half of the respondents went shopping at least once a week (57%) and the remaining shopped almost every day (43%) for household milk supplies.

Table 5.2: Respondents' dairy milk shopping habits

Weekly milk consumption	Frequency	%
Milk intakes		
Less than 2 pints	163	28.8
2 to 3 ½ pints	252	44.6
More than 3 ½ pints	150	26.5
Milk category		
Whole milk	174	30.8
Semi-skimmed milk	336	59.5
Skimmed milk and 1% fat milk	55	9.7
Type of milk		
Conventional	481	85.1
Others: organic, animal welfare, lactose– free	84	14.9
Store to shop for milk		
Large supermarket	422	74.7
Supermarket chain local shops	99	17.5
Others: milkman, farmer's market, local store	44	7.8
Shop for milk		
Almost everyday	241	42.7
At least once a week	324	57.3
Preferable milk packaging		
Plastic	423	74.9
Glass	82	14.5
Tetra Pak (paper– based)	60	10.6
Disposal of milk packaging		
Recycle bin	485	85.8
Others: general waste, home compost, milkman	80	14.2

This shopping habits section of the questionnaire also required respondents to give information about their superior milk packaging and how they dispose of it. 75% of the respondents selected plastic bottles as the best packaging for milk, followed by 15% glass and 11% Tetra Pak (paper-based) as milk packaging. This result seems consistent with the milk packaging available in the UK market, which mostly involves plastic bottles and this study also focused on an option to replace the plastic packaging with a more environmentally friendly choice. As for the disposal of their milk packaging, the majority are recycling their milk packaging (86%) and other disposal options (14%) such as garden pots, home composting, general waste bin and return the bottle to the milkman.

5.3 Exploring the latent variables of the VBN to predict WTP

Understanding the psychological perspective of respondents' pro-environmental behaviour has been operationalised through the hierarchical model of the VBN theory. The model focused on how an individual's environmental values and beliefs could provide a variation of their behaviour towards food packaging waste. The VBN proposed framework had been explored by two sub-models of equation modelling through IBM AMOS. The primary concern of the SEM is to assess the relations among the VBN-latent variables with WTP to buy bioplastic among the respondents. However, prior to that, a measurement model (also known as confirmatory factor analysis) is an important preliminary step in the analysis to ensure the validity and reliability of the indicators (observed items) for latent variables. According to Byrne (2010), once it is known that the measurement model is operating adequately, the full structural equation model of the proposed model can be assessed more accurately.

Figure 5.1 shows the initial measurement model (Model 1) path diagram with all the indicators (observed items) of the VBN latent variables. The ecological values of EGO, ALT and BIO latent variables were represented by four indicators each, the NEP was measured by fifteen indicators and lastly, the AC, AR and PN were evaluated by nine indicators each. In total, 54 indicators built up Model 1 (Figure 5.1) of the measurement model. However, the results of the model fit indices in Table 5.3 indicate that the measurement model 1 is a very poor fit to the data to measure the latent variables. All the fit indices of the fit model were below the standard determination. RMSEA is at a mediocre fit level of 0.075, the model fit of GFI is below the acceptable level with 0.61 as well as TLI of 0.71 and CFI of 0.73. Thus, it is apparent that some modification is needed to identify a model that better represents this research data of the consumer. To assist the model modification, the estimates regression weight table in Appendix 16 was used in the process to find a better fit model for the data. The post-hoc analysis of the regression weight estimates (in Appendix 16) for measurement model 1 identified that three indicators (N6, AC9R and AR5R) were insignificant with the data at the 0.05 significant level. Therefore, those indicators were deleted in the next measurement model.

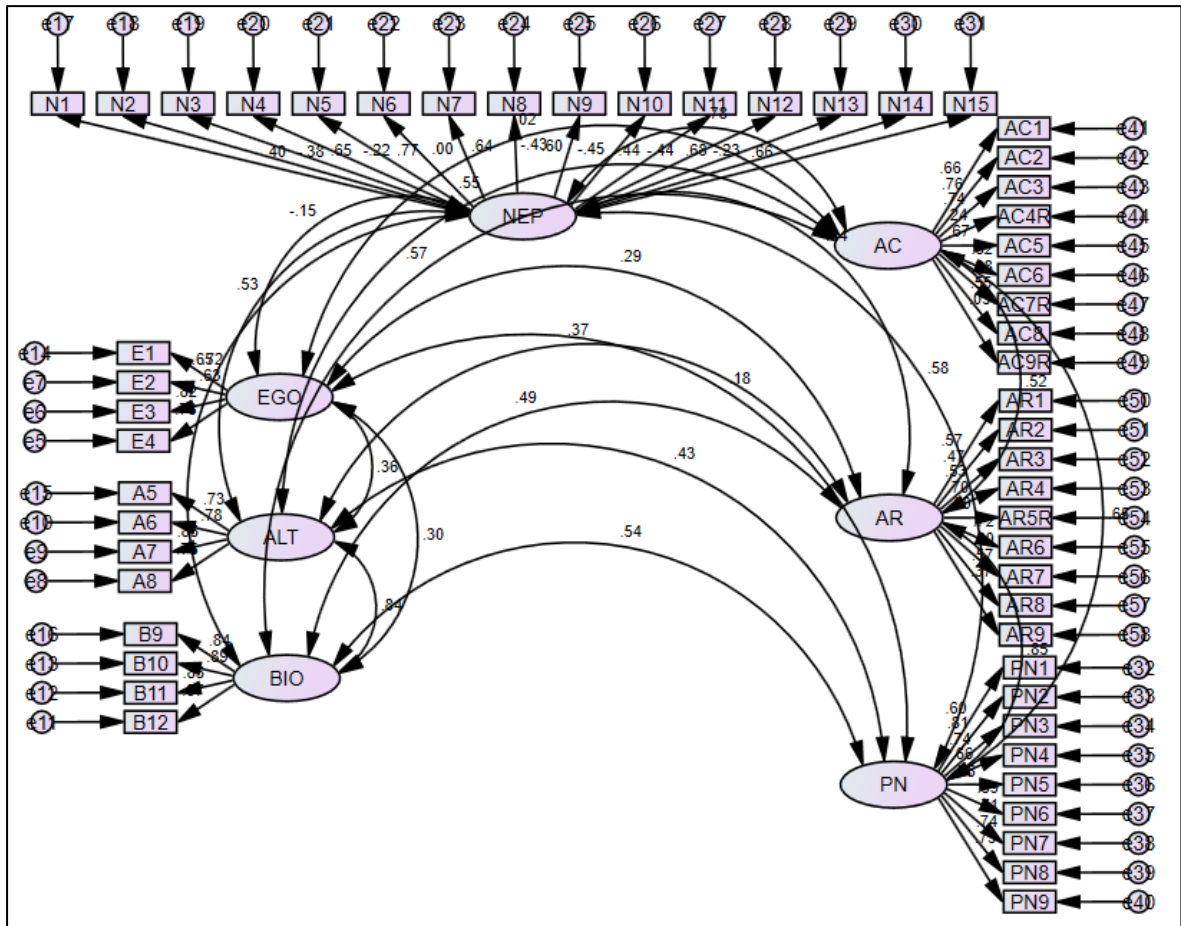

Figure 5.1: Initial measurement model (Model 1)

Measurement Model 1 summary:

Number of distinct sample moments =	1485
Number of distinct parameters to be estimated =	129
Degree of freedom (1485 – 129) =	1356
Chi-square =	5618.04
Probability level =	0.001

Table 5.3: Initial measurement model (Model 1) fit indices

Fit indices	RMSEA	CFI	GFI	TLI	CMIN / DF
Standard determination	< 0.06	> 0.90	> 0.90	> 0.90	1 – 3
Model fit	0.075	0.73	0.61	0.71	4.14

Besides looking at the significance of the regression weight estimates table, the modification indices (MI) could also be used to improve the model fit. According to Byrne (2010), high MI values of the indicators are the possible causes of the model misspecification. For example, in Table 5.4, indicator AR2 of the sample data supposed to measure responsibility feeling of respondents towards food packaging waste seems to measure the personal norm indicator (PN6). MI of 49.64 explained that

if PN6 uses to predict AR2, the discrepancy (chi-square) will fall by at least 49.64, and the estimate of the parameter would change at 0.288; thus, the goodness-of-fit model will eventually improve. The arrow to the left could indicate that, although AR2 was postulated to load on the AR variable, it may load more appropriately on the PN variable. Therefore, it was deleted in the next re-specification model (Byrne, 2010). It is feasible that those indicators have something specific in common that is correlated (Hox & Bechger, 1998). The MI section indicated some possible improvements to the model and identified areas of any misfit in the model through the covariance of error terms and regression weights. The post-hoc analyses were conducted repeatedly until the all fit indices achieved the standard determination values.

Table 5.4: Part of MI of regression weights in measurement Model 14

Regression Weights: (Group number 1 - Default model)				
			M.I.	Par Change
AR8	<---	AR3	14.462	.108
AR8	<---	AR2	10.753	-.085
AR8	<---	PN7	12.508	-.097
AR8	<---	PN5	16.172	-.117
AR8	<---	N9	14.290	.133
AR7	<---	PN4	17.432	.155
AR2	<---	PN	26.839	.321
AR2	<---	PN9	25.067	.233
AR2	<---	PN7	34.198	.249
AR2	<---	PN6	49.637	.288
AR2	<---	PN5	44.701	.302
AR2	<---	PN3	38.744	.281
AR2	<---	PN2	17.710	.200
AR2	<---	PN1	16.676	.174
AR2	<---	E1	12.676	.068
AC8	<---	EGO	11.685	.066
AC8	<---	E3	12.296	.051

The better-fit measurement model suited with this research data was finally achieved in Model 21, as shown in Figure 5.2 (see Appendix 17 for the regression weight estimates in detail). All the fit indices are in the standard determination range for a fit model, as shown in Table 5.5. Only 32 indicators of VBN-latent variables in measurement model 21 (Figure 5.2) were used to evaluate structural equation of the proposed VBN model. The estimation of model 21 yielded an overall GFI value of 0.91, RMSEA of 0.042, CFI of 0.95 and TLI of 0.94, as shown in Table 5.5. This model 21 was found to be exceptionally good to measure the latent variables and was statistically significant with $\chi^2_{(443)}$ of 876.17.

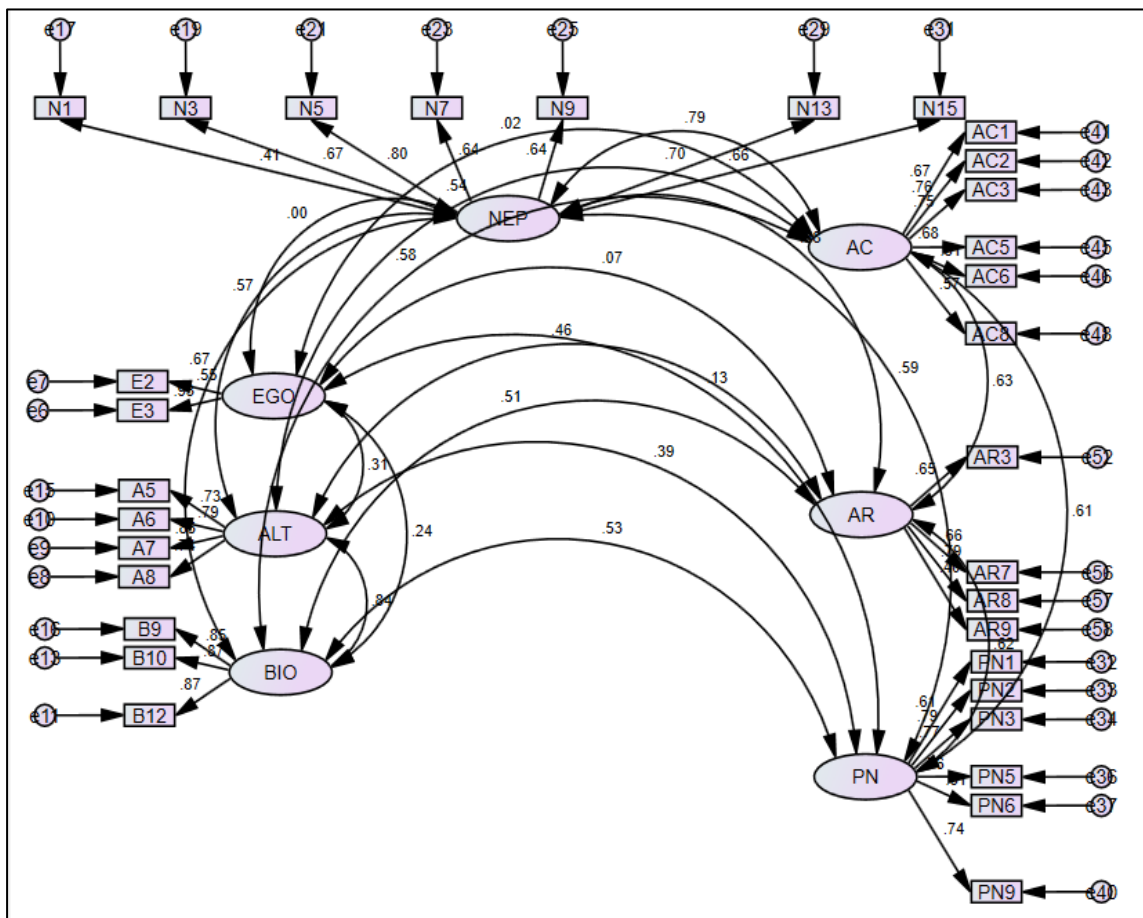

Figure 5.2: Final measurement model (Model 21)

Measurement model 21 summary:

Number of distinct sample moments =	528
Number of distinct parameters to be estimated =	85
Degree of freedom (528 – 85) =	443
Chi-square =	876.17
Probability level =	0.001

Table 5.5: Final measurement model (Model 21) fit indices

Fit indices	RMSEA	CFI	GFI	TLI	CMIN / DF
Standard determination	< 0.06	> 0.90	> 0.90	> 0.90	1 – 3
Model fit	0.042	0.95	0.91	0.94	1.98

In order to achieve the results of measurement model 21, the MI of the regression weight estimates of every measurement model was closely revised to ensure indicators are not cross-loaded with one another which will create a misspecification of the structural model analysis. In total, 22 indicators were filtered out based on the high MI values of the regression weight estimates. Most omitted indicators were from AR and NEP where those indicators were cross-loaded with other indicators in the model that caused the misspecification of the model.

Following the measurement model, 32 indicators of seven latent variables (EGO, ALT, BIO, NEP, AC, AR, PN) were assembled to predict the pro-environmental purchasing behaviour of bioplastic packaging. This structural model served as a full causal model, which is the next step of SEM to evaluate the causal structure linking between latent components towards environmental purchasing behaviour as proposed in the study framework, previously. Only two estimation models significantly enough to achieve fit structural model (Model 1 and Model 2). Figure 5.3 below displayed the final structural model summary, and the model fit indices are shown in Table 5.6.

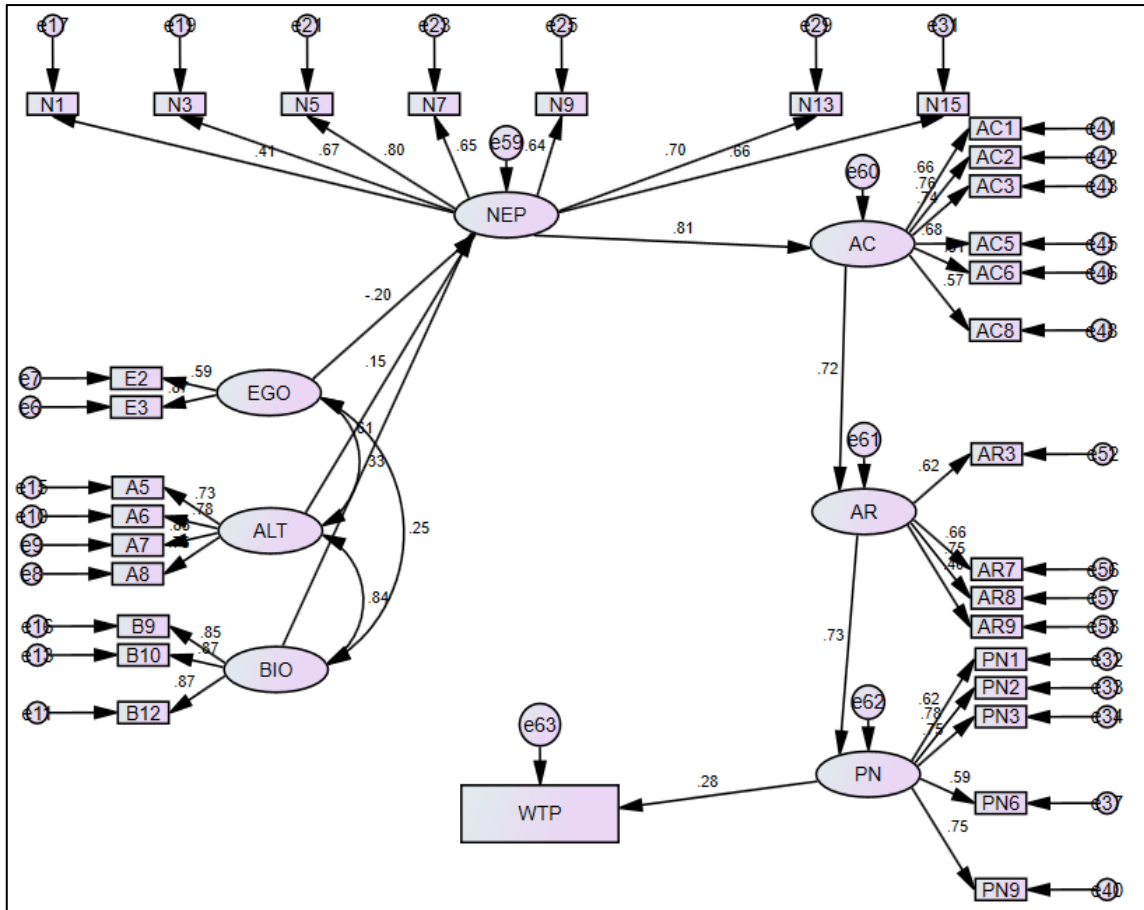

Figure 5.3: Final structural model (Model 2)

Structural model 2 summary:

Number of distinct sample moments =	528
Number of distinct parameters to be estimated =	73
Degree of freedom (528 – 73) =	455
Chi-square =	951.19
Probability level =	0.001

Table 5.6: Structural model fit indices

Fit indices	RMSEA	CFI	GFI	TLI	CMIN / DF
Standard determination	< 0.06	> 0.90	> 0.90	> 0.90	1 – 3
Model 1	0.044	0.94	0.89	0.93	2.09
Model 2	0.044	0.94	0.90	0.93	2.09

As shown in Figure 5.3, an observed continuous variable of the WTP from the CV method was included as the pro-environmental behaviour or outcome of the VBN causal model. In Table 5.6, showcasing the restructuring of the indicators during the measurement model estimation, the goodness-of-fit of the structural model (Model 1) is relatively well-fitting as indicated by CFI of 0.94, TLI of 0.93, RMSEA of 0.044, which

are within the recommended range and acceptability. However, the GFI of Model 1 is slightly below the acceptable level with the GFI at 0.89. Again, the same procedure to improve the structural model (Model 1), MI showed that high MI value was associated with the regression path from PN5 to AR8 at MI of 16.16. The value indicated that if this indicator was freely estimated in the subsequent model, the overall χ^2 value would drop by at least this amount. Therefore, PN5 was deleted in the structural model (Model 2) as shown in Figure 5.3. The estimation of Model 2 (Table 5.6) yielded an overall χ^2 (455) of 951.19 value, an RMSEA of 0.044, CFI of 0.94, a GFI of 0.90 and a TLI of 0.93, which is a better fit than the previous model to predict WTP (see Appendix 18 for details on the regression path estimates).

Although the structural model (Model 2) showed improvement in model fit, it indicated that the standardised path coefficient between ALT and NEP fell slightly short of significance at a 90% confidence interval with p-value = 0.11 (Table 5.7). Further reviewing the latent variables' correlation estimates, as shown in Table 5.8, revealed that there was a correlation value of 0.84 between ecological values ALT and BIO, which is an indication of possible multicollinearity. According to Byrne (2010), multicollinearity arises from the situation where two or more variables are highly correlated that they both essentially represent the same underlying construct; even the model found to be exceptionally good.

Two or more variables are said to be colinear when they measure the same construct or item. In this sense, the ecological variables of ALT and BIO may closely correlate if the statements related to these two variables are seen as referring to the slightly similar object viewpoint (e.g. ALT measures ecological concern to human and BIO measures concern of animal and plant) by the respondents. For example, item B10 "respecting the environment" and item A5 "Equality" in Appendix 12, respondent most likely referring these two statement on the same perspective when answering it. Moreover, the other possible technical reasons two variables are said to be correlated if both data vary in harmony with each other, even though the variables may measure totally different items. Lastly, multicollinearity typically occurs when two variables that are hypothesized to be casually related measure the same construct (Kock & Lynn, 2012). In this study, the BIO and ALT variables were linked by arrow pointing to NEP (Figure 5.4) and each other as the requirement for SEM to be converge (Figure 5.3).

Table 5.7: Hypothesis testing of the VBN-based research framework

Hypothesis	Path coefficient	p-value	Decision
H1	0.15	0.11	Rejected
H2	0.61	***	Accepted
H3	- 0.20	***	Accepted
H4	0.81	***	Accepted
H5	0.72	***	Accepted
H6	0.73	***	Accepted
H7	0.28	***	Accepted

*** Significant at 0.05

Table 5.8: Correlation estimates between the exogenous variables

Correlations: (Group number 1 - Default model)		
		Estimate
EGO <-->	ALT	.333
EGO <-->	BIO	.250
ALT <-->	BIO	.842

On the basis of this rationale, the ALT path regression will be excluded from the subsequent econometric analysis to avoid multicollinearity issues. This exclusion was supported by a study of environmental awareness on a green product by Ziaei-Bideh and Namakshenas-Jahromi (2014) where the egoistic value had been excluded in the final structural model due to insignificance at the 95% confidence interval to achieve a fit VBN model for the study. Overall, the results of the SEM analysis of the proposed model are reported in Table 5.7.

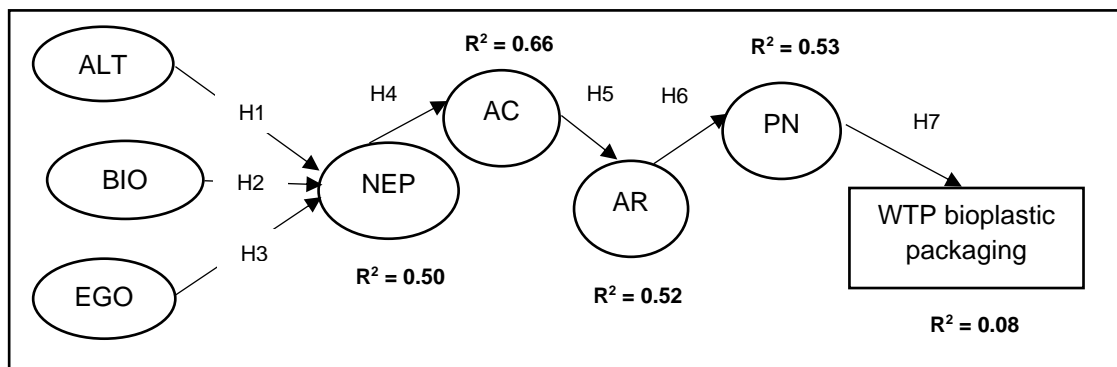

Figure 5.4: Proposed research framework

In bringing this section to a close, all of the standardised path coefficients which form the causal paths in the VBN-based framework to predict pro-environmental behaviour were statistically significant at $p < 0.001$, except H1 where the ALT value was found to

be insignificant with the data sample of this study. Meanwhile, Table 5.7 shows that for other exogenous ecological values, BIO has the highest connection ($H2 = 0.61$), whereas the EGO value had a negatively low connection with respondents' behaviour ($H3 = -0.21$). Among the four other latent components of the framework measuring the WTP of bioplastic packaging, a person's overall perception on the environmental situation (NEP to AC) had the highest connection ($H4 = 0.81$), whereas the actual pro-environmental action (PN to WTP) had the weakest relationship ($H7 = 0.28$). This demonstrates that personal norm towards environmental protection significantly influences a person's actual pro-environmental purchasing behaviour, even at the low connection of 0.28.

The proposed research framework (Figure 5.4 and Table 5.7) confirmed that the causal links proposed by the VBN theory of pro-environmental behaviour exist and the finding was supported by this study data. The SEM results indicated that there is an influence of one latent variable in predicting another behaviour. As shown in Figure 5.4, the majority of causal path coefficients explained approximately 50% from NEP, 66% from AC, 52% from AR and 53% from PN of the total variance in their respective outcome variables. Overall, the subsequent analysis will use the SEM results with 32 items from the structural model (Model 2). Table 5.9 below shows the descriptive statistic and reliability test on the VBN-based research framework.

Table 5.9: Mean and reliability test of the VBN latent dimensions

Variables	Mean	α
Egoistic	3.75	0.7
Biospheric	5.60	0.9
NEP	4.08	0.8
AC	4.01	0.9
AR	3.87	0.7
PN	3.65	0.9

The mean of the variables was the accumulation of the total scores calculated divided by the total items belonging to that variable. Overall, based on the mean values, the respondents were sensibly practising an environmental behaviour and were aware of the consequences if they cared less for environmental health. In terms of the reliability of these variables, the tests indicated significant reliability, all Cronbach's α above 0.6 even after the SEM analysis. This showed that the latent variables were dependable to generate substantial results to represent the England population in this pro-environmental behaviour study on purchasing innovated sustainable packaging.

5.4 Heterogeneity of preferences for bioplastic packaging attributes with and without the influence of attributes cut-off violations

At this part of the chapter, the respondents were given six choice situations, each with three milk packaging alternatives, where two were bioplastic dairy milk packaging alternatives and a status quo packaging. As proposed by this study, an extension of cut-off violations was included in the traditional compensatory utility maximisation model in the WTP space. Incorporating the violations of attribute cut-off variables into the choice model formulation is purposely to investigate the non-compensatory preferences of respondents towards the bioplastic's attributes, as suggested by Swait (2001). Table 5.10 below presented the frequency of cut-off statements violation from the 10,170 choice situations of 565 respondents.

Table 5.10: Frequency of self-reported cutoffs and instances cut-offs violations

Cut-off statements	Self-reported cut-off	Violation of cut-off
I only purchase bioplastic from tree cellulose	1530	510
Only recyclable packaging	3510	1560
Only biodegradable packaging	1260	280
Yes, for the certification logo on the label	5364	1788
Maximum price between 5% to 20% increases	6930	588

Numbers of violation	Frequency	%
0	5924	58.2
1	3778	37.1
2	456	4.5
3	12	0.1

The frequency of cut-off violations was calculated when a respondent's self-reported cutoff statements (in section 7 of questionnaire Appendix 12) were against his choice for milk packaging alternatives in the choice experiment section. For example, if a respondent selects that tree cellulose is the non-compensatory attribute of the bioplastic material for him; however, he chooses bioplastic from agricultural waste in one of the choice situations. This indicates that he violated his self-reported attribute cut-off statement and essentially does not have strong non-compensatory preferences as he reported. Of these, Table 5.10 shows that the cut-off of tree cellulose was violated 510 times; the bioplastic certified label cut-off was violated 1788 times; the maximum price cut-off was violated 588 times, and the disposal option cut-offs of recyclable and biodegradable were violated 1560 and 280 times, respectively. Out of 10,170 choice situations, more than half of the choices (58%) had not violated the self-

reported cut-offs; while the majority of respondents' choices had violated only 1 cut-off (37.1%) and few choices involved violations of 2 cut-offs (4.5%) and 3 cut-offs (0.1%).

The most common attribute cut-off violations made by the respondents were the availability of bioplastic certification on the label and also the recyclable options attributes. Attribute cut-off is a heuristic rule that a person considers for simplifying the choice decision (McFadden, 2001). However, when the respondents have been exposed to the distraction of other attributes among packaging alternatives, they tend to show disjunctive behaviour in their choice strategies. These violations probably occur due to the importance of other attributes (Grether & Wilde, 1984) and the growing interest of the new attributes such as biodegradable options, instead of commonly known recyclable packaging. Moreover, even though product information is an important aspect of the food product, the certification logo does not seem to be a primary attribute considered by the respondents and has mostly been violated in the choice decision of the experiment. A study by Riberio et al. (2018) stated that information on nutritional contents, ingredients, best before date, location and the packaging date on the food product are the most important factors that influence the purchasing.

The violation attribute cut-off parameters were then applied in the estimation of ML models to explore the preferable attribute of that sustainable packaging. Two different logit models in the WTP space are outlined in Table 5.11, where Model 1 is a full compensatory choice model (original RUM), and Model 2 is with the attribute cut-off violations model (extension of violation attribute cut-offs). The comparison of two models with corresponding violation parameters has shown an improvement in the goodness-of-fit of the model. A standard procedure to measure the ML goodness-of-fit is to examine AIC, BIC and log likelihood estimates, where small values of AIC and BIC and higher log likelihood indicate a better estimation model (Cameron & Trivedi, 2010). The goodness-of-fit of Model 2 in Table 5.11 indicated a better improvement than Model 1 due to the presence of five violation parameters. The log likelihood increased by – 2836.97, while AIC and BIC decreased by 5715.94 and 5867.71, respectively from Model 1. The addition of attribute violation variables into the utility function of choosing sustainable packaging significantly increased the model fit, suggesting that the utility model estimation without cut-off violation parameters (Model 1) was rejected.

Table 5.11: ML models with and without attribute cut-off violations in WTP space

Mean	Model 1	Model 2
Tree cellulose (ref. agricultural waste)	– 0.293*** (0.049)	– 0.163*** (0.021)
Disposal option: Recyclable (ref. compostable)	0.031 (0.029)	0.066*** (0.017)
Disposal option: Biodegradable (ref. compostable)	0.099*** (0.028)	0.076*** (0.015)
Certified logo on package label (ref. no label)	0.137*** (0.028)	0.131*** (0.014)
Tree cellulose cut-off violation		– 0.294*** (0.031)
Recyclable option cut-off violation		0.020 (0.019)
Biodegradable option cut-off violation		– 0.049 (0.039)
Certified label cut-off violation		– 0.670*** (0.029)
Maximum price cut-off violation		– 0.504*** (0.070)
Constant	– 0.194 (0.022)	0.0005 (0.015)
SD		
Bioplastic tree cellulose (ref. agricultural waste)	0.641*** (0.053)	0.348*** (0.024)
Disposal option: Recyclable (ref. compostable)	0.407*** (0.046)	0.206*** (0.019)
Disposal option: Biodegradable (ref. compostable)	0.176*** (0.036)	0.082*** (0.014)
Certified logo on package label (ref. no label)	0.435*** (0.040)	0.264*** (0.018)
Tree cellulose cut-off violation		0.323*** (0.046)
Recyclable option cut-off violation		0.243*** (0.020)
Biodegradable option cut-off violation		0.087** (0.043)
Certified label cut-off violation		0.715*** (0.035)
Maximum price cut-off violation		0.299*** (0.109)
Log likelihood	– 3102.00	– 2836.97
AIC	6226.02	5715.94
BIC	6305.52	5867.71
Number of choice sets	10 170	10 170

Significant at 5% level, *significant at 1% level

AIC = Akaike's information criterion

BIC = Bayesian information criterion

The figures in parentheses are standard errors.

The introduction of the violation parameters had also changed the magnitude of the WTP for the bioplastic packaging attributes. All the WTP coefficients of the violation parameters in Table 5.11 are negative and significant, except for the recyclable and biodegradable violations, which were not significantly different from zero. The negative magnitude is indicating that the violations of self-reported cutoffs have resulted in utility losses to the respondents, also known as utility penalty. For example, if the respondent violates the tree cellulose cut-off, he will be subjected to a utility penalty of – £ 0.29. In the results of Model 2 (Table 5.11), the largest utility loss was when the respondents violated the maximum price violation which he or she had lost – £ 0.50 of total utility. This parameter suggested that violating the price cut-off had a larger impact on the utility loss than violating other self-reported cutoff statements.

In Table 5.11, the comparison between the WTP estimates of two ML models' attributes had also significantly changed between with and without the incorporating violation parameters. In Model 1, the WTP of bioplastic from tree cellulose was lower by – £ 0.29 if compared to the WTP of agricultural waste bioplastic. However, in Model 2 with a violation parameter indicated that choosing tree cellulose bioplastic only reduces the utility by – £ 0.16 and violating the tree cellulose cut-off resulted in a utility penalty of – £ 0.29. So, the maximum WTP of that particular attribute is the summation of WTP estimates plus the WTP of violation estimates as shown in the equation below.

$$\text{Max WTP}_{\text{nit}} = (1 - \text{No purchase}) \beta X_{\text{nit}} + \beta V_{\text{nit}} + \epsilon_{\text{nit}} \quad (1)$$

Similarly, the WTP for the bioplastic certification label on the packaging only had the utility maximised by £ 0.13, instead of £ 0.14 (in Model 1) compared to the no certification label attribute level. Model 1 shows an overestimated the utility prediction by £ 0.01. Regarding the WTP of disposal options, respondents were most likely willing to pay more on the biodegradable bioplastic than compostable by £ 0.08 in Model 2; as well as recyclable bioplastic at £ 0.07. In particular, the WTP of the recyclable option had improved from insignificant to significant results in Model 2. The differences in the results of two ML models suggest that failure to account for attribute cut-offs and their violations tend to overestimate the true utility maximisation that decision-makers gain when purchasing the entire product (Ding, Veeman & Adamowicz, 2012; Swait, 2001). Overall from the ML estimation, a respondent may assume that he has the non-compensatory attribute which he tried to employ when making a choice; however, it

appears that the respondent does not have a strong non-compensatory attribute and suffers some utility penalty of the sustainable packaging chosen.

To further assess the WTP differences between with and without attribute cut-offs parameters, Figure 5.5 represents the kernel density graphs that compare the changes between those ML models (Model 1 and Model 2). The kernel density estimations were the post-estimation of the WTP estimates (from equation (1)) with the mean of every attribute calculated. The results of the post-estimation have then been displayed in the distribution graphs to show differences between the WTP of Model 1 and WTP of Model 2 in Figure 5.5. In Figure 5.5 (a), there are clear differences of WTP between with a model without the violations (Model 1); where the WTP of tree cellulose bioplastic showed the largest WTP mean interval. Instead of – £ 0.33, on average, respondents' unwillingness to pay for the tree cellulose was – £ 0.18 than the agricultural waste bioplastic material.

On the other hand, other attributes displayed small marginal improvement on the average of WTP towards the based attribute references. Figure 5.5 (b) the WTP of the certified label on the package had lowered by £ 0.02 in Model 1 where the actual WTP for certification label was £ 0.12. In the same way with the biodegradable bioplastic in comparison with compostable bioplastic of Figure 5.5 (c) that indicates £ 0.02 lower from the WTP £ 0.10 in Model 1. However, Model 1 of the recyclable bioplastic attribute was insignificantly different at zero (£ 0.02*) but significantly different in Model 2 with an average of WTP at £ 0.06 (Figure 5.5 (d)). This supports the proposition that the introduction of the violation parameters into the utility model is capturing the effects that are not reflected or overestimate the full compensatory utility of Model 1.

Overall, the results indicate that all the bioplastic milk packaging attributes were preferable to the respondents if compared with the based group, except tree cellulose bioplastic where respondent more likely to favour agricultural waste more than tree cellulose. Further, from the results, it can conclude that the ML along with the non-compensatory choice approach is more suitable for measuring the valuation of bioplastic milk packaging than ML compensatory model (without violation parameters). This is because WTP estimation results differ considerably between both models that employed compensatory and non-compensatory approach, suggesting that cut-off endogeneity might lead to biased estimates or overestimation in the model without cutoff violations. The results also provide support to the non-compensatory theory by Swait (2001), where ignoring the attribute cut-off violations in the utility model can give significant errors of WTP estimates. This error estimates will result the choice

prediction may become ineffective in the representation of consumer's portion of utility function and consumer do not achieve fully utility maximisation.

Last but not least, in regards to this non-compensatory approach, two understanding can be made from the results. First, the actual attributes of bioplastic milk packaging that is non-compensated by respondents. For examples of the results above, respondents more likely preferred agricultural waste bioplastic that is biodegradable and recyclable with clear certification of the bioplastic source on the label. Secondly, how much consumers suffer utility loss if they violate the self-reported cut-offs. For example, in Table 5.11, if respondents violated the certification label cut-off, he or she had loss – £ 0.67 of the total utility for the choice.

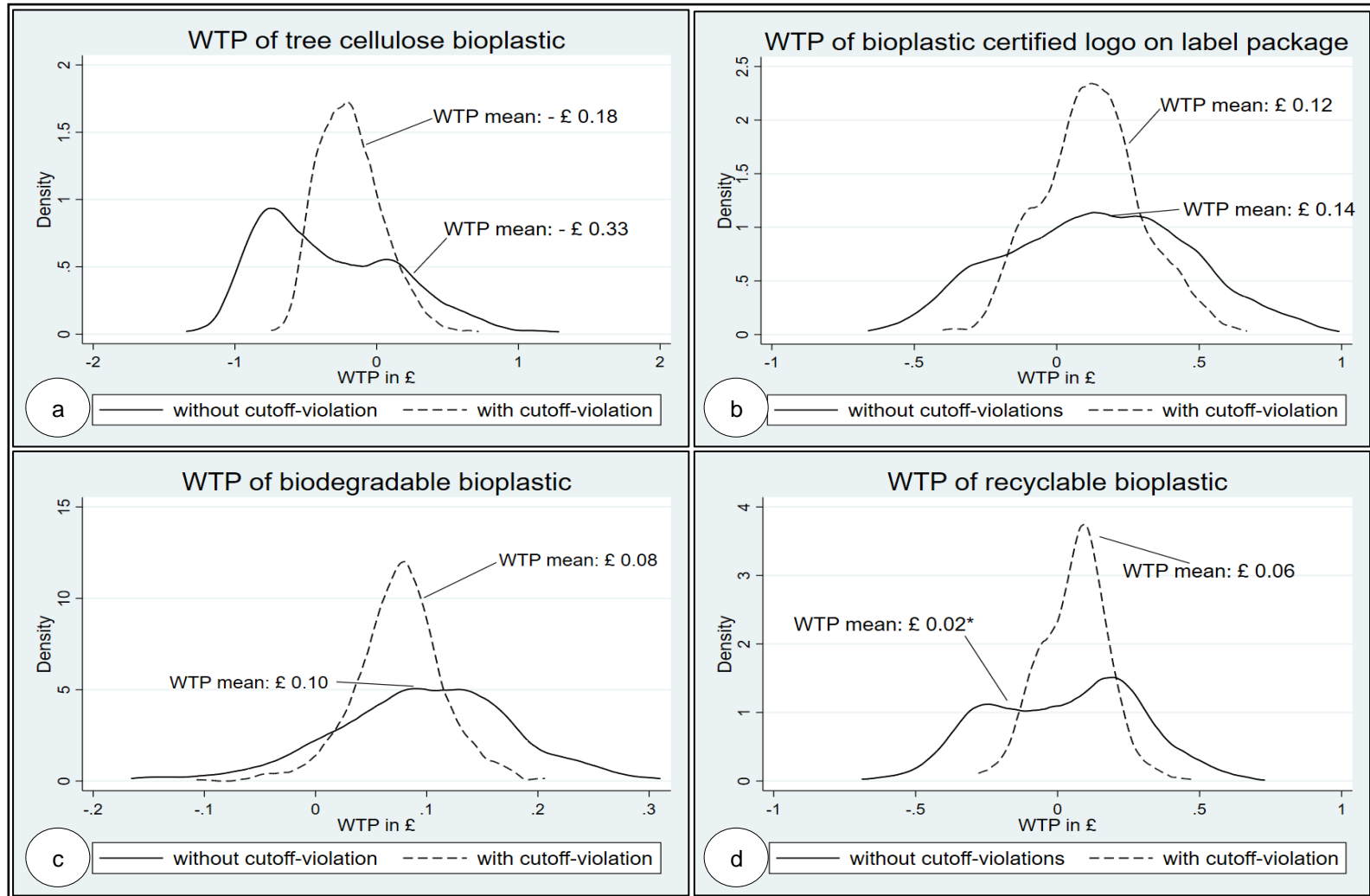

Figure 5.5: WTP differences with Model 1 (—) and Model 2 (- - -)

A further analysis of the differences of WTP of each attribute (Model 2) with regard to the respondent's socio-demographic profiles and dairy milk shopping habits had been completed with the analysis of variances (ANOVA) and Independent t-test. The results found that only income and age groups had significant differences with the tree cellulose bioplastic with reference to the agricultural waste bioplastic packaging. Figure 5.6 compares the estimated WTP of tree cellulose bioplastic between age and income groups. In the WTP of the income groups, there was a significant difference between groups as determined by $F = 4.06$, $p = 0.018$. A Bonferroni post-hoc test was statistically significant between the low income group with both middle- and high-income groups at $p = 0.009$ and $p = 0.053$, respectively (see Appendix 19 for details). The WTP kernel density showed a clear peak of – £ 0.22 for the low income group in comparison to other income groups which were slightly differenced with each other at – £ 0.15 (high income) and – £ 0.152 (medium income). The results signified that the low income group is more unwilling to trade off to agricultural waste bioplastic than tree cellulose. This is probably the reason why they are low in the budget to spend on this new packaging of dairy milk and unfamiliar with the concept of the packaging or uncertain with the term 'cellulose'.

Similarly, with the age groups, the ANOVA test was significantly differenced at $F = 5.89$ and $p = 0.003$. All the peaks presented show negative peaks where the post-hoc test indicated that only young and older groups of respondents had a significant difference at $p = 0.029$. Young consumers would be unwilling to pay at – £ 0.16 less of tree cellulose bioplastic with reference to agricultural waste. However, the older consumer would be unwilling to give up – £ 0.23 for tree cellulose, which is £ 0.07 more on agricultural waste bioplastic than young consumers. It seems that the older generation would like to spend more on the reduce farm waste rather than forest industry waste. On the other hand, the young generation would prefer to experience tree cellulose more probably due to the social media exposure of new packaging material. Overall, both income and age groups of consumers are significantly showing interest in bioplastic materials where there were minor changes of WTP between both packaging materials.

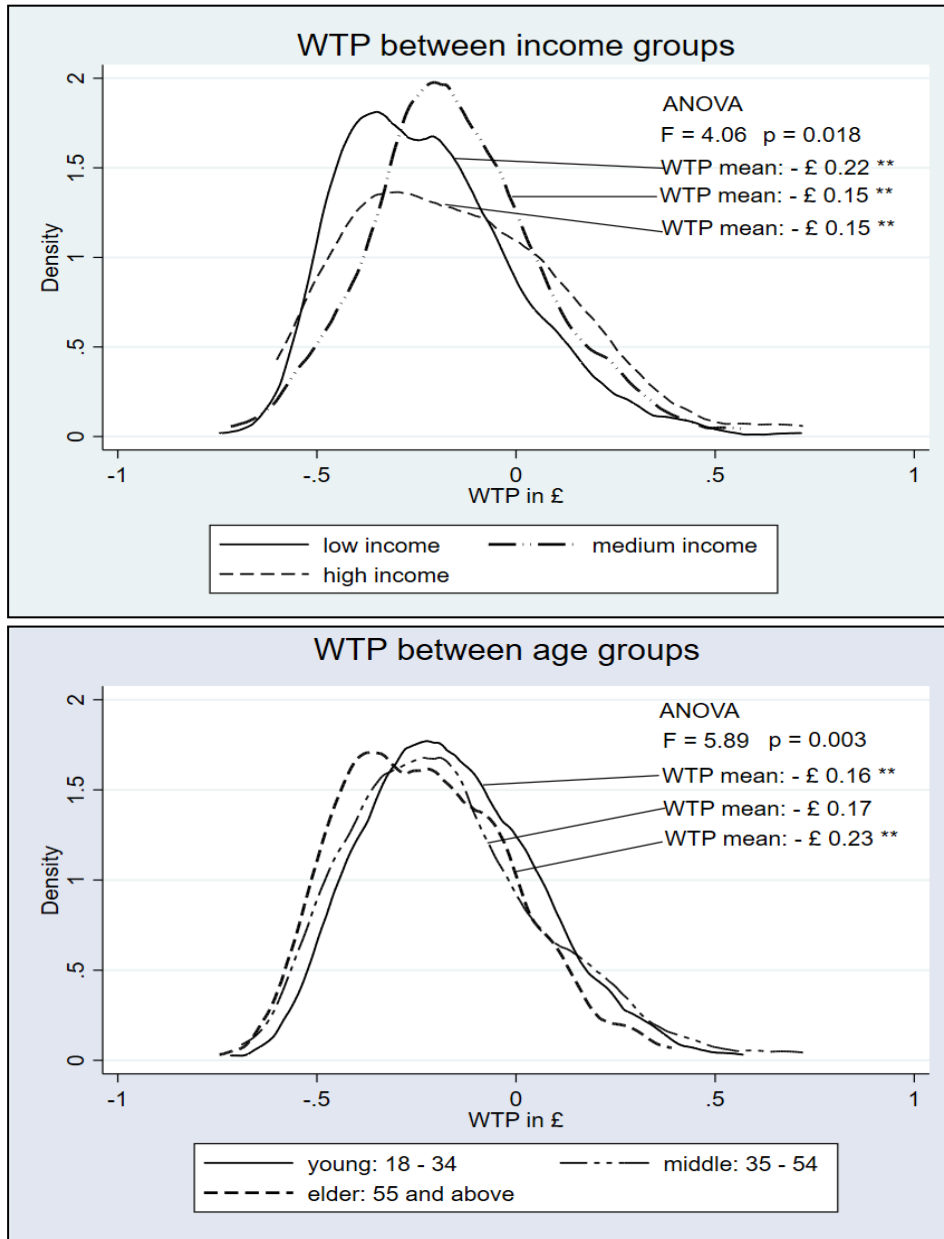

Figure 5.6: WTP differences between age and income groups of tree cellulose bioplastic

In terms of the WTP of milk shopping habits, the results show that personal preferences of milk types and the frequency of milk purchase found to have significant differences with the tree cellulose bioplastic with reference to the agricultural waste bioplastic packaging. While 'disposal option of milk packaging' found to significantly different with the recyclable WTP with reference to the compostable option of bioplastic. Figure 5.7 compares the estimated WTP of tree cellulose bioplastic between respondent's milk type preference and milk procurement groups.

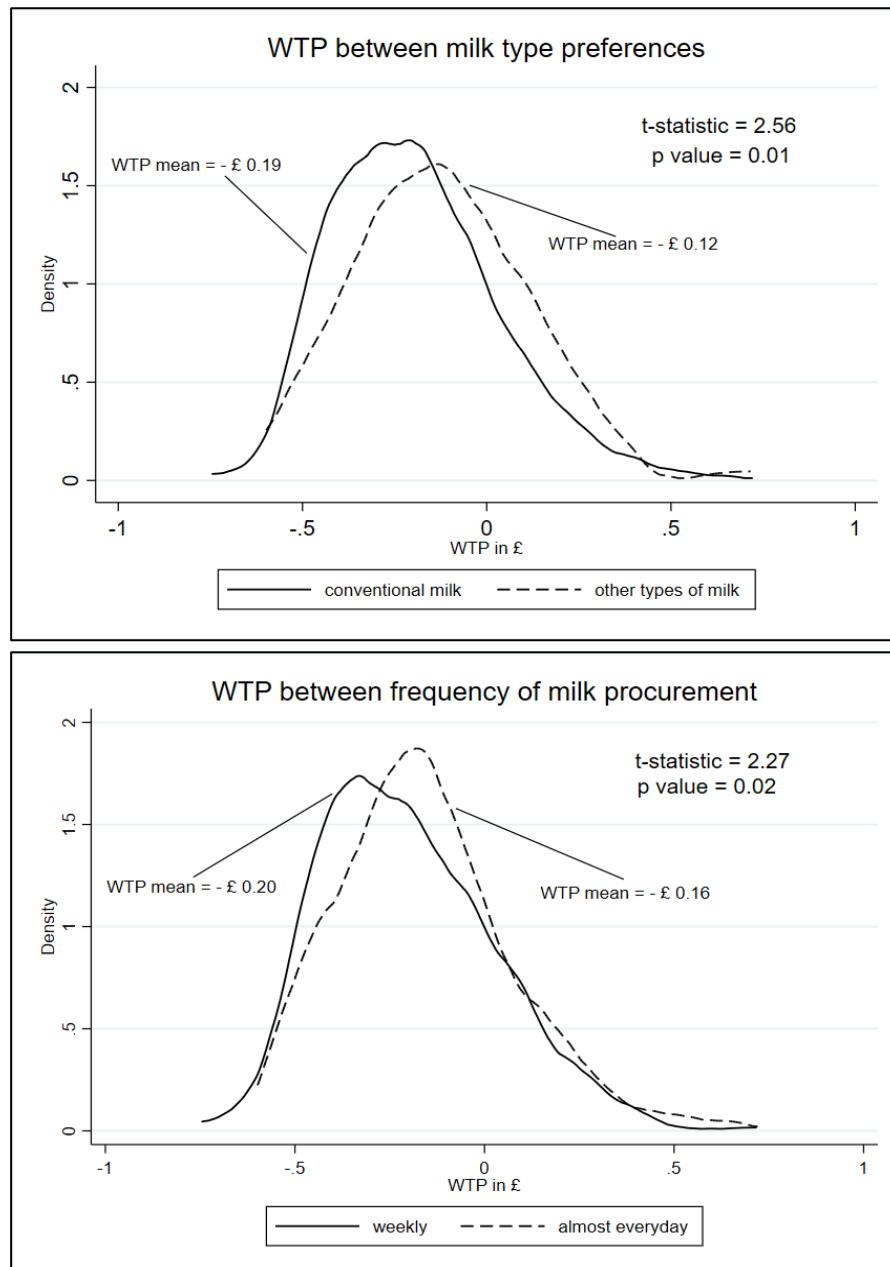

Figure 5.7: WTP differences between milk type and procurement groups of tree cellulose bioplastic

In the WTP of milk type preferences among respondents, there was a significant difference between respondents who bought conventional dairy milk and other types of milk such as organic, animal welfare or lactose-free as determined by t-statistic = 2.56 and p-value = 0.01 (see Appendix 21 for details). The WTP kernel density graph above shows that conventional milk users were more unwilling to choose tree cellulose bioplastic compare to the other types of milk users by - £ 0.07 differences with reference to the agricultural waste bioplastic. This probably happened due to the information given prior answering the CE task. The information supplied might be complex to understand, and only respondents' that environmentally concern such as animal welfare and organic product buyers would understand the information. On the other hand, there was a significant difference between WTP of respondents' who frequently buy milk with respondents' who buy milk on weekly basis at t-statistic = 2.27 and p-value = 0.02. Weekly buyers were unwilling to pay more than frequent milk buyers. They were unwilling to spend - £ 0.20 of tree cellulose bioplastic with the reference of agricultural waste bioplastic. However, the regular milk buyers would be unwilling to pay on - £ 0.16 for tree cellulose bioplastic, which is £ 0.04 less than another group.

Finally, the independent t-test analysis showed that only WTP of 'disposal option of milk packaging' group was significant differences as verified by t-statistic = - 2.13 and p-value = 0.03. Respondents would prefer to recycle their bioplastic milk packaging rather than another way of disposal (e.g. home compost, general waste bin). Figure 5.8 of kernel density pictured the differences between WTP of that two groups of disposal option variable. Respondents that choose recycle container were willing to pay more on the recyclable bioplastic at £ 0.06 if compare to another group which only willing to spend £ 0.06. It seems that respondents in England are familiar with the recycle packaging and more, the UK government encourages the recyclability as explained in qualitative study in chapter 3. Moreover, due to the unpredictable weather in the UK and location of the respondent's house (e.g. flat, student halls, limited land space) would make compostable is impossible option to dispose of their solid waste.

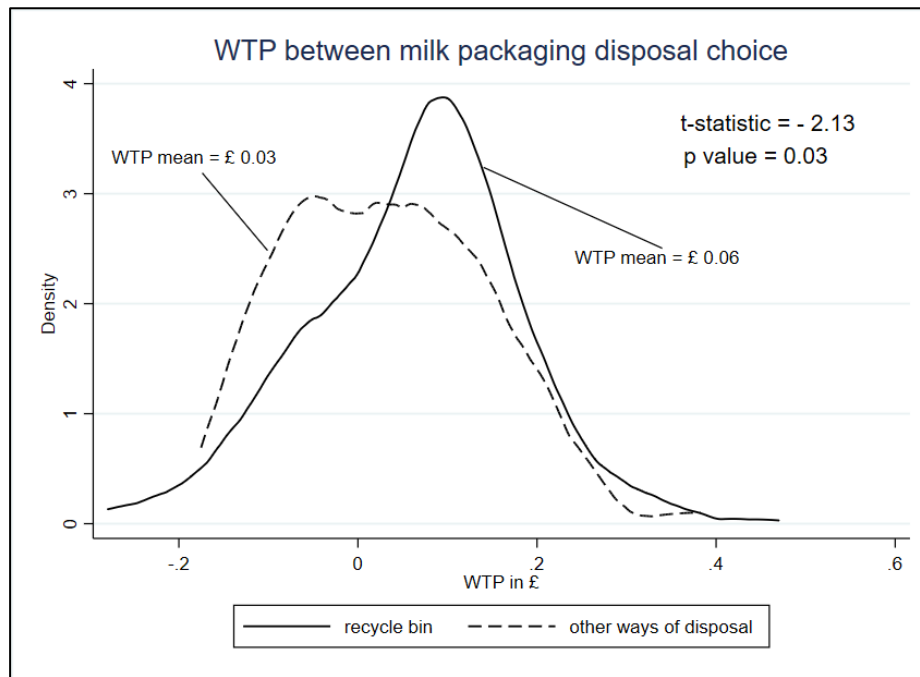

Figure 5.8: WTP recyclable option of bioplastic among different milk packaging disposal habit groups

The latent class logit (LC) model results are depicted in Table 5.12. The results compared the differences between LC models with and without cut-off violation parameters, which are divided into five classes. The selection of the class number is based on the minimum values of information criteria such as log likelihood and BIC, and 5 class model showed to be appropriate with this study data. With the involvement of additional attribute cut-off violation parameters, the findings summarised that there is some modification of the variable magnitudes, as shown in Table 5.12, specifically for attribute bioplastic material and its disposal options. In Classes 1 and 2 of LC without violation parameters model (coefficients in parentheses), it showed that respondents preferred bioplastic obtained from agricultural waste less at -0.18 and -4.38 ; however, in LC with violation parameters model, both classes showed positive signs toward tree cellulose than agricultural waste at 0.23 and 11.33 , respectively. Similarly, the recyclable option of bioplastic was in favour in Class 1 (0.11) and 2 (5.06) but unwillingly chosen by the LC with the violation model at -0.32 and -9.15 . The certification attribute of bioplastic was the only variable that showed no difference in both LC models. Based on the ML and LC results, this study was selected to report the LC model with attribute cut-off violation parameters as the final consumer segmentation of bioplastic milk packaging. Therefore, the parameter used to explain

class membership and characterise the consumers was the LC model with the violation parameters.

Table 5.12: Latent-class logit model with five classes based on the choice decision

Variables	Class 1	Class 2	Class 3	Class 4	Class 5
Tree cellulose (ref. agricultural waste)	0.23 (- 0.18)	11.33 (- 4.38)	0.10 (1.06)	- 1.18 (5.10)	- 3.12 (- 29.64)
Disposal option: Recyclable (ref. compostable)	- 0.32 (0.12)	- 9.15 (5.06)	0.53 (- 0.53)	- 1.20 (- 0.25)	3.25 (6.07)
Disposal option: Biodegradable (ref. compostable)	0.23 (0.60)	- 14.24 (3.59)	0.18 (- 0.11)	- 0.02 (- 1.18)	3.20 (5.57)
Certified logo on package label (ref. no label)	0.03 (0.24)	2.63 (1.48)	1.28 (1.06)	0.78 (1.49)	0.88 (24.51)
Tree cellulose cut-off violation	0.05	- 67.88	- 1.44	3.17	- 1.79
Recyclable option cut-off violation	- 0.63	- 1.20	0.73	- 1.80	0.20
Biodegradable option cut-off violation	0.29	- 5.64	- 0.98	3.25	2.43
Certified label cut-off violation	- 1.33	- 266.24	- 24.36	0.53	- 0.32
Maximum price cut-off violation	0.24	- 43.74	- 86.40	- 2.78	- 3.02
Class membership probabilities	0.27 (0.32)	0.18 (0.29)	0.20 (0.18)	0.11 (0.16)	0.24 (0.06)
Log-likelihood			2628.44		
BIC			5599.07		
CAIC			5653.07		

The figures in parentheses are latent-class logit model without violation of attribute cut-offs

Class 1 is the one of the 'label-concerned group' where if the respondents violated the self-reported certified label cut-off, the utility of choosing that packaging decreased at -1.33. Likewise, Class 2 is gaining most utility from the certified label attribute as Class 1 and the package with the bioplastic logo was of the most preferred attribute of bioplastic packaging; this class was most likely described as the 'information-trusting group'. Out of 10,170 choice situations, Class 3 consumers suffered the most if they violated the maximum price cut-off at - 86.40, which may possibly be implied as the 'price-sensitive group'. The fourth class seems to be more deliberate in its decision strategy to choose agricultural waste as bioplastic material. This was demonstrated by gaining more utility satisfaction when the violated tree cellulose was cut off at beta 3.17 and loss at beta - 1.18 if they choose tree cellulose. So, 'farm-waste buyers' is the only relevant decision criterion to describe Class 4. Lastly, Class 5 consumers are unlikely to choose the compostable option of bioplastic to compare to other classes. This is due to the violation of recyclable and biodegradable cut-off providing more utilities of chosen packaging at 0.20 and 2.43 and possibly known as 'compostable avoiders' group of consumers. Given the result of the class membership with violation parameters, the data comprised most of Class 1: label-concerned group (27%), Class 5: compostable avoiders (24%) and Class 3: price-sensitive group (20%). There is only

a small portion of Class 2: information-trusting group (18%) and Class 4: farm-waste buyers (11%).

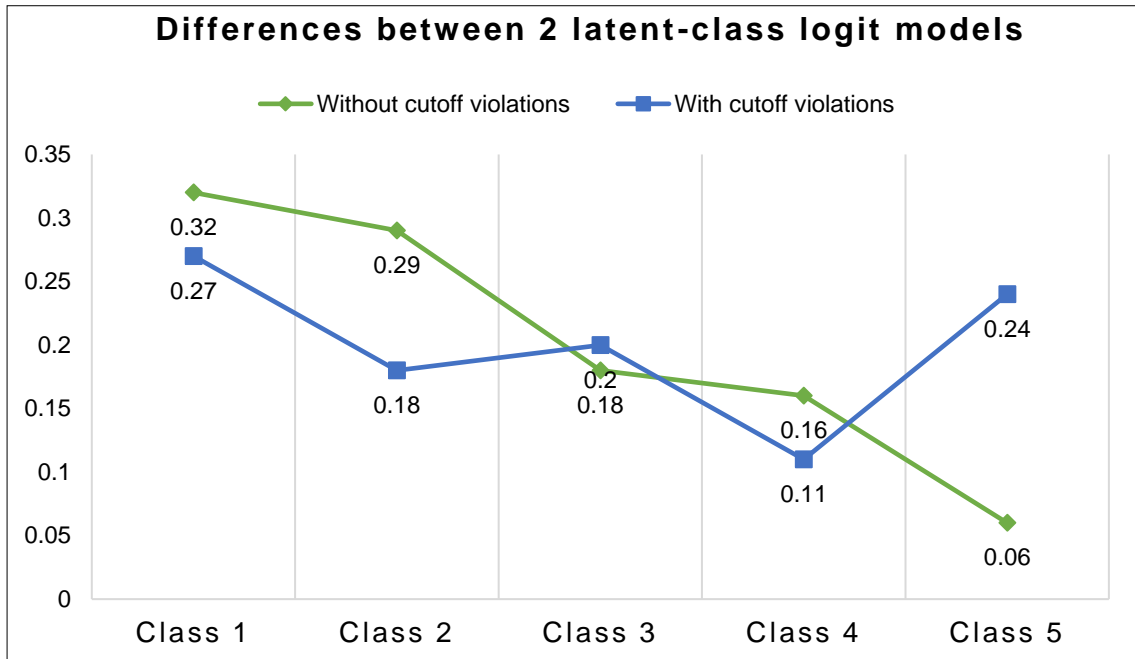

Figure 5.9: Differences between with and without attributes cut-offs of CL models

Taking the involvement of the violation parameters, the differences of class segmentation can be clearly seen in Figure 5.9 above as well. The largest class was Class 1 for both models that comprised 32% without the cut-off violation model and 27% for another model. Meanwhile, the smallest segment of the data was Class 5 for without violation model at 6% and Class 4 for with violation model at 11%. Overall, the full compensatory LC model (without violation) is more likely to overestimate of certain classes (Class 1, 2 and 4) and underestimate Class 3 and Class 5 on the segmentation of bioplastic packaging preferences. In this study, the presence of attribute cut-off violation parameters into the utility estimation model of consumers' choices for bioplastic sustainable dairy milk packaging has proven the positive implication to actual evaluation respondents' WTP. It also provides empirical evidence that some respondents tend to use the attribute cut-offs technique in their decisions to purchase. However, some respondents are claimed to have non-compensatory attributes when choosing a food product but acted differently when facing the varieties of packaging alternatives. The results also show that consumers do not always adhere to their self-reported cut-offs but are willing to take a utility penalty rather than eliminate an alternative when the violation occurs.

5.5 WTP of agricultural waste bioplastic for food product packaging

A CV method had been adopted to further analyse consumers' WTP on agricultural waste bioplastic for food packaging on the market. Previous results of ML models on bioplastic packaging attributes indicated that the majority of respondents preferred to spend on agricultural waste more than tree cellulose as the bioplastic material. However, there were also a minority of respondents unwilling to pay more on that agricultural waste packaging, as shown in Table 5.13 below. A total of 486 respondents had a positive WTP, while 79 respondents were not willing to spend on agricultural waste bioplastic packaging, and the two accounted for 86.1% and 13.9%, respectively. It suggested that if bioplastic packaging was marketed, the vast majority of local consumers would be keen to spend their food expenditure for environmental protection.

Table 5.13: Frequency of WTP for agricultural waste bioplastic food packaging

WTP	Frequency	%
Yes	486	86.1
No	79	13.9
Protest	51	9.0
True zero	28	4.9

Nevertheless, there were two different groups of non-WTP respondents found in this study. 9% out of 14% non-WTP respondents were identified as a protest group; while only 5% of respondents were truly unwilling to pay for agricultural waste bioplastic packaging due to an economic condition such as household budget constraints. More details on the no-WTP are shown in Figure 5.10.

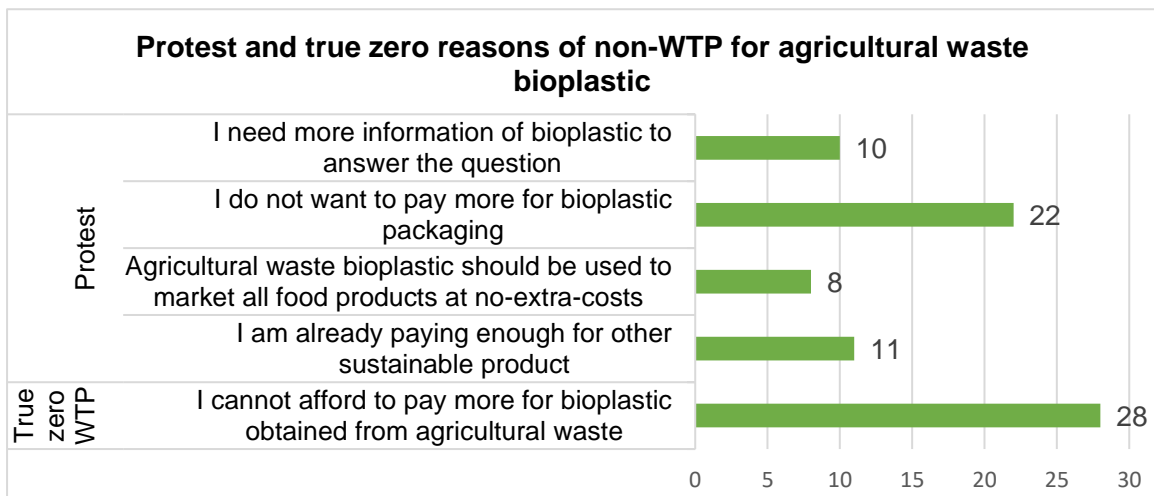

Figure 5.10: Frequency on protest and non-protest of zero WTP for agricultural waste bioplastic food packaging

Out of 79 respondents that were unwilling to pay, 22 respondents protested by voting the refusal statement to spend more on bioplastic packaging. Then, 11 more respondents selected another monetary statement saying that they had paid enough for other sustainable products, and 8 respondents chose the protest statement that the agricultural waste bioplastic should be marketed without any extra cost. A similar study on ecological and environmental protection mentioned that the consumers who refused to pay more because they are already paying taxes and fees to the local government to protect the environment (Xiong et al., 2018). Among the protest reasons, one non-monetary reason was selected by 10 respondents saying that they need further information on bioplastic. This was supported by a study revealing that the addition of eco-labels to provide more knowledge to the consumer in China does increase consumers' knowledge, but yet the WTP for food products does not increase with the knowledge (Liu & Zhou, 2017). Thus, respondents who declined to pay more on the packaging probably felt that they had already paid in another version of contribution such as environmental volunteering or correctly managed household waste, but not in the monetary form. Moreover, respondents probably need more exposure to this new packaging material as it is still in its infancy stage in the UK. Thus, from this non-WTP results, only true zero WTP of 28 respondents were included as 0 WTP in the Tobit regression analysis.

5.5.1 Factor influencing the WTP for agricultural waste bioplastic packaging

Table 5.14 reported the Tobit regression analysis of the WTP for agricultural waste bioplastic packaging. In order to evaluate the factor that influences the UK consumers' WTP for bioplastic packaging, a model was constructed using data obtained from the survey. A total of 18 explanatory variables were included, such as VBN variables, consumers' characteristics and past behaviour as shown in the equation below. These variables are related to the socio-demographic background, knowledge on bioplastic and also, in this case, the aforementioned VBN constructs resulted from the structural model in SEM.

$$Y^* = WTP^* = \begin{cases} B'X + e & \text{if } WTP > 0 \\ 0 & \text{otherwise} \end{cases}$$

Where;

$$WTP_n^* = \beta_0 + \beta_n \text{Gender} + \beta_n \text{Age} + \beta_n \text{Edu} + \beta_n \text{Job} + \beta_n \text{Familysize} + \beta_n \text{Bioplastic} + \beta_n \text{VBN} + e_n$$

Table 5.14: Tobit regression analysis on the demographic and psychological variables on the WTP of agricultural waste bioplastic food

Variables		Coefficients WTP	SD	t	$\partial E(y x, y>0) / \partial x$ Marginal effects on being censored	$\partial E(y^* x) / \partial x$ Marginal effects on being uncensored
Gender	Female	0.36*	0.20	1.82	0.26	0.33
Age	35 to 54	- 0.40*	0.23	- 1.79	- 0.30	- 0.37
	55 or older	- 0.43	0.35	- 1.24	- 0.32	- 0.39
Education	High education	- 0.05	0.20	- 0.25	- 0.04	- 0.05
Income	Middle	0.94***	0.22	4.32	0.68	0.85
	High	1.30***	0.30	4.34	0.97	1.19
Occupation	Skilled / services	- 0.15	0.26	- 0.57	- 0.11	- 0.14
	Retired	- 0.09	0.38	- 0.23	- 0.06	- 0.08
	Unemployed	- 0.28	0.26	- 1.06	- 0.20	- 0.25
Family size	Couple	1.15***	0.24	4.79	0.78	1.00
	Family with children	1.32***	0.26	5.11	0.92	1.17
Heard about bioplastic	Agricultural waste: Yes	0.56**	0.21	2.73	0.42	0.52
VBN constructs	EGO	- 0.05	0.06	- 0.93	- 0.04	- 0.05
	BIO	0.20**	0.08	2.57	0.15	0.18
	NEP	- 0.26	0.23	- 1.13	- 0.19	- 0.23
	AC	0.58**	0.21	2.83	0.43	0.53
	AR	0.16	0.16	0.98	0.12	0.15
	PN	0.09	0.17	0.51	0.06	0.08
	Constants	- 1.87**	0.80	- 2.34		
Model statistics	Log-likelihood				- 1063.22	
	Sigma				4.138***	
	Mean WTP				£ 2.72	
	Minimum WTP				- £ 0.27	
	Maximum WTP				£ 5.49	
	SD				£ 1.09	

* Significant at 0.10, ** Significant at 0.05, ***Significant at 0.0001

In Table 5.14, the first column after the variables includes the Tobit regression coefficients, which are interpreted in a similar manner to other linear regression coefficients and followed by the standard deviation and t-statistic values. Two marginal effects coefficient estimates in the last two columns represented the probability of marginal impact on the expected value of WTP given by the changes in explanatory when the WTP was being censored ($y > 0$) and when the WTP was being uncensored (y^*). The marginal effect on being censored estimated the impact of positive WTP only, meanwhile the uncensored marginal effect includes left-censoring of WTP in the estimation.

The model was statistically significant with optimising the log likelihood of -1063.22 and estimated standard error (σ) of 4.14 . The results of this study indicated that respondents were willing to pay more approximately $\pounds 2.72$ on average with minimum WTP $-\pounds 0.27$ and maximum WTP $\pounds 5.49$ for agricultural waste bioplastic food packaging. Out of 18 explanatory variables, nine including the constant were significant at 5%, 10% and 1% of the confidence interval, respectively. The constant was negatively significant ($p < 0.00001$) at $-\pounds 1.87$ when all the variables were not included. In reference to the socio-demographic explanatory variables, only gender, middle age group, income and family size were significant to the WTP estimations. Figure 5.11 and Figure 5.12 showed the latent WTP* differences of those significant factors of explanatory variables.

In Table 5.14, gender shows significance at 0.10 where female respondents are willing to spend more on bioplastic food packaging obtained from agricultural waste in comparison with male respondents by spending $\pounds 0.36$ of their weekly expenditure on it. Similarly, a probability of change in one unit of female variable will also result in a positive WTP of $\pounds 0.26$ ($y > 0$) and $\pounds 0.33$ (y^*) increase compared to the male. The kernel density graph in Figure 5.11 (a) proves that females on average are willing to spend $\pounds 2.89$ while males do so at $\pounds 2.45$. The previous study on sustainable wine showed similar results where females are willing to spend more compared to men (Vecchio, 2013). Moreover, females reveal stronger preferences for environmental protection (Torgler & Garcia-Valinas, 2007) and higher WTP for food products related to health functions (Vecchio, Van Loo & Annunziata, 2016).

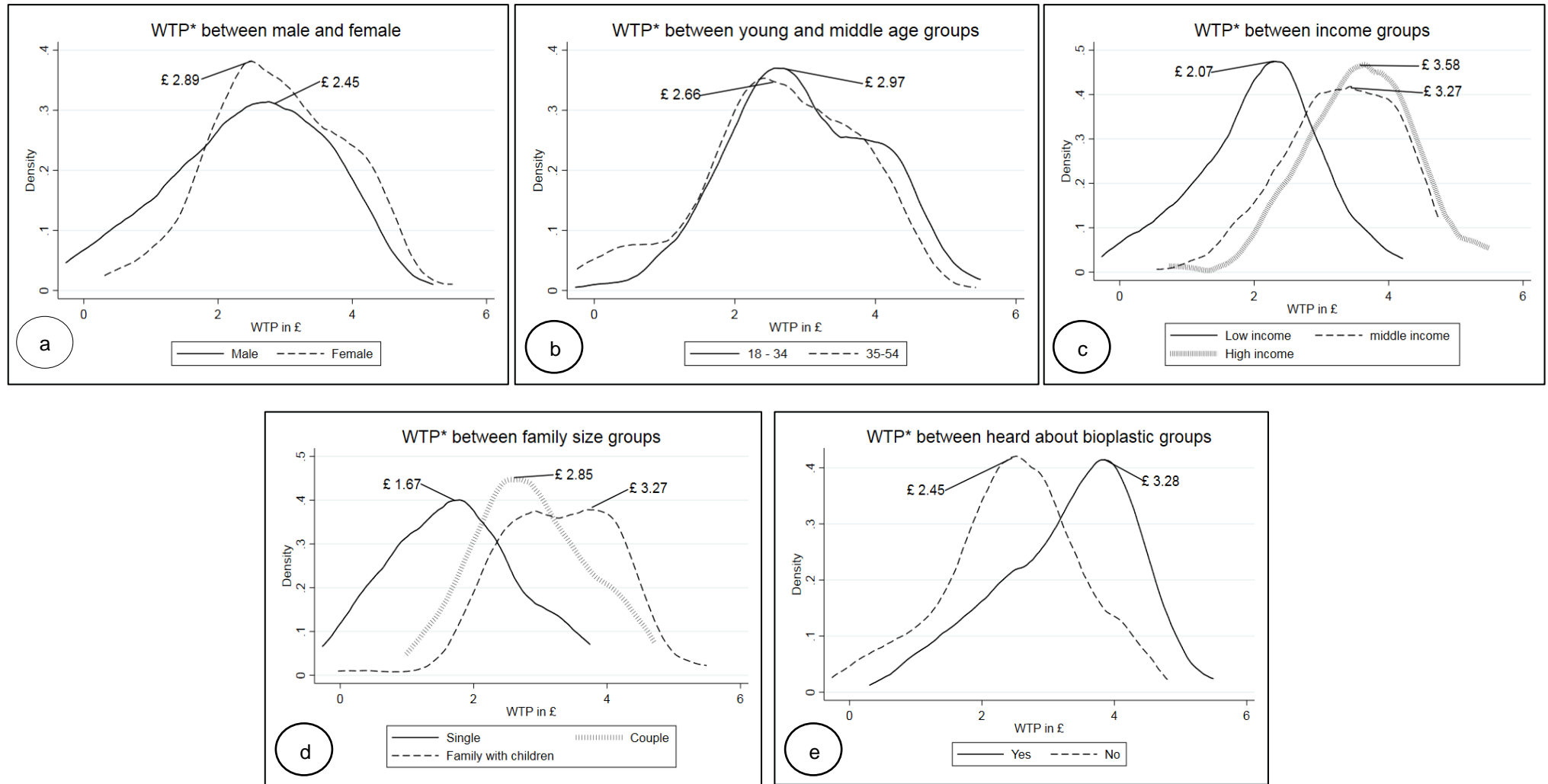

Figure 5.11: Kernel density estimation of the WTP*(latent y^*) of significant sociodemographic factors

Another significant explanatory variable in Tobit in Table 5.14 is the respondent's age. However, only the middle age group of respondents is positively significant in comparison to the young age group. Respondents aged 35 to 54 were willing to spend less by – £ 0.40 compared to youngsters on the new packaging. The marginal effects indicate that when one unit increased in age, the probability of WTP decreased to – £ 0.30 of censored WTP and – £ 0.37 for uncensored WTP. In particular Figure 5.11 (b), young respondents were spending on average £ 2.97 for bioplastic packaging while middle age respondents chose to spend £ 2.66 extra from their weekly food expenditure on bioplastic packaging. This empirical finding is not surprising because young consumers lean towards a trendy product compared to older groups (Lemken et al., 2017). Moreover, the aforementioned focus group results indicated that older participants were prone to the conventional way of packaging using paper-bags to wrap the product and unenthusiastic to accept any innovation.

Furthermore, on the socio-demographic variable, both income groups were significant at $p < 0.0001$ in Table 5.14. The results are understandably significant due to a better financial condition where the high income and middle income group could afford to spend more compared to low income respondents. The middle income group was willing to spend £ 0.94 more of their weekly food expenditure on bioplastic packages, and an increase of income would result in a £ 0.85 increase in the WTP overall (uncensored WTP) respondents and £ 0.68 increase from those respondents with positive WTP ($y > 0$). In the same way, the high income group would spend £ 1.30 of their weekly expenditure on bioplastic food packaging and the amount increased by one unit change of the income to £ 1.19 of actual WTP (y^*) and £ 0.97 of truncated WTP. On average in Figure 5.9 (c), low income respondents were willing to give up £ 2.07, and middle income respondents agreed on £ 3.27 of their weekly food budget; meanwhile, high income respondents were set at £ 3.58 to spend on new innovated packaging. A study on premium sustainable food product also showed similar results on the income explanatory variable where higher income consumer willing to spend more on the premium food product than other income groups (Lemken et al., 2017).

Another significant factor of sociodemographic, family size shows an interesting outcome where a family with children was willing to spend more on new bioplastic packaging than single and respondents with a partner, as shown in Table 5.14. They willing to give up about £ 1.32 of their family's food expenditure buying food wrapped in bioplastic packaging and an increase the family size, the WTP is also inclined by £ 0.92 of positive WTP ($y > 0$) and £1.17 more on actual WTP (y^*). On the other hand, the family size of two adults (couple) estimation shows WTP of £ 1.15 if compared to

single household respondents. This indicated that they are also ready to spend £ 1.15 more, but less than the bigger family size on bioplastic packaging. If one unit changes in family size, couple group's WTP will increase by £ 0.78 among those non-zero WTP respondents and £ 1.00 on marginal effects being uncensored. Figure 5.11 (d) shows that single group's WTP was an average of £ 1.67, couple group's WTP was at £ 2.85 and family with children group's was £ 3.27. These interesting findings proved that when consumers concern the well-being of their family members, they are willing to spend more to save the environment.

The Tobit analysis also indicated that respondents with additional knowledge on sources of bioplastic show a significant WTP at 0.05 in Table 5.14. The result proves that respondents with some knowledge on bioplastic would spend £ 0.56 more on that new packaging than respondents with no knowledge. The more knowledge gained on bioplastic would increase the WTP by £ 0.42 ($y > 0$) and £ 0.52 (y^*). This is probably because consumers place greater value on the sustainability attribute of the bioplastic material by knowing the insight benefits of it. Moreover, knowledge of the sustainable label of food products provides confidence in the consumer to trade-off their money with the premium quality of the product (Vecchio, 2013).

Finally, it is advantageous to explore the VBN latent variables on the WTP of bioplastic packaging because it could be insightful information on the most influential environmental values that affect respondents' WTP of this bioplastic packaging. Six VBN constructs resulting from the SEM had been introduced into the Tobit regression estimation, as shown in Table 5.14. Only the BIO and AC constructs significantly supported the proposed idea of that pro-environmental model. According to Stern et al. (1999), the positive biospheric ecological value (BIO) indicates a strong concern towards the protection of flora and fauna. So, the result seems to be consistent with the VBN hypothesis, where a higher environmental concern among the respondents leads to an increase in WTP by £ 0.20. If a unit changes on that ecological value, the WTP will change by £ 0.15 for positive WTP ($y > 0$) and £ 0.18 when the data being uncensored (y^*).

Specifically, Figure 5.12 below revealed that the WTP was positively increasing when the BIO and AC scores were increasing. Moreover, the finding confirms the association between the awareness of negative consequences for others or things that someone values when not acting pro-environmentally by the significant result of the AC variable. The higher the awareness of not managing their food packaging waste properly, the higher the likelihood the WTP will increase by £ 0.58. A unit of positive change on the

AC would result in a £ 0.53 increase in the WTP level for all respondents, and a £ 0.43 increase in WTP for those truncated respondents.

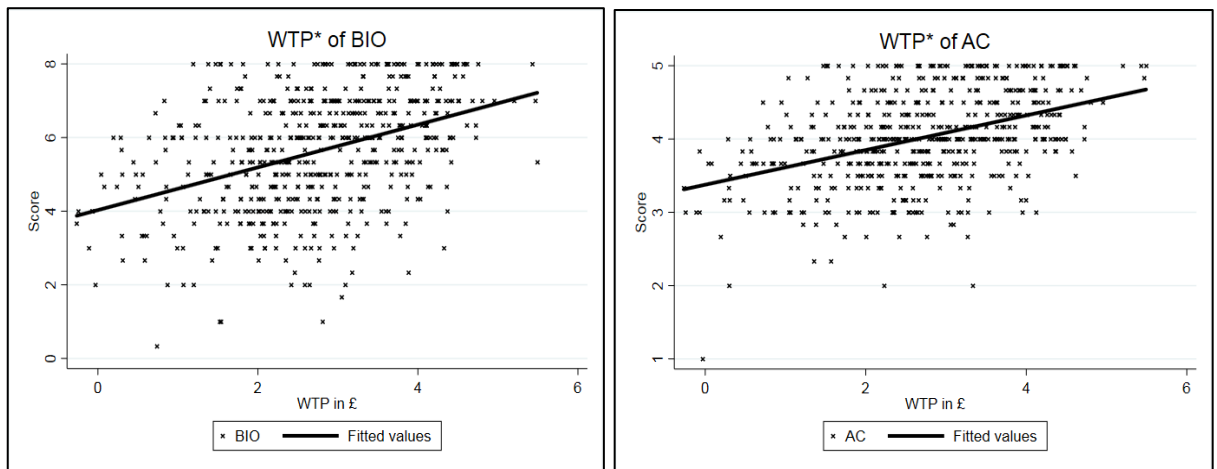

Figure 5.12: Kernel density estimation of the WTP* (latent y^*) of significant VBN factors

5.6 Conclusions

The chapter notes some interesting findings on various aspects of consumer acceptance of bioplastic food packaging. Through the SEM, the measurement model finally achieves the best fit on measurement model 21 with the latent variables that best represent each component of the VBN. Later, structural model 2 appears to best clarify WTP through the VBN hierarchical constructs where 8% variance was explained by the path regression from latent variable PN to WTP of bioplastic packaging. Surprisingly, the SEM analysis found that the ALT latent variable is not significant to the proposed VBN model due to the multicollinearity with the BIO variable. Therefore, it is then excluded for further analysis. Two econometric analyses are applied to further examine the acceptance of bioplastic packaging. ML in the WTP space with attribute cut-off violations was revealed to be a significantly better model to capture the actual utility maximisation of respondents during the choice experiment situations. The addition of cut-off violations parameters into the full compensatory model provide precise utility estimation in term of monetary value. Among the bioplastic milk packaging attributes, agricultural waste material that can be recycled and biodegraded are the preferable attributes; besides reference may also be made to the availability of certification on the package. These findings enhance the understanding of the best combination of the innovative bioplastic packaging that markets should focus on. To

increase comprehension, there are five latent classes of consumer segmentation that emerged in this study. Lastly, the regression indicated female, young, not single, adequate household income and respondents with additional knowledge on bioplastic are the consumers' characteristics that have a significant positive impact on WTP bioplastic packaging obtained from agricultural waste. Moreover, consumers that care for nature conservation and have awareness of the negative impact of waste also agreed to spend more on the new plant packaging. Lastly, it is suggested that respondents' WTP on bioplastic packaging lies between – £ 0.27 and £ 5.49, with an average of £ 2.72 for the all respondents in this study.

CHAPTER 6

CONCLUSION

There are several sustainable development and initiatives organised by many industries, including the food and drink industry to produce less solid waste for a cleaner environment, particularly from food packaging waste in the UK. For example, the carrier bag charge of 5 pence and reusable cups discount on campus and in the coffee shop. Recently, the sustainable packaging market has been growing in the UK due to the landfill limitation and accumulation of solid waste in the country. The food industry searches for any material that helps to decrease the environmental problem, parallel to the EU Directive amendment to design a packaging that minimises the negative influence on the environment throughout the life cycle. Even though bio-based food packaging material has been a topic of interest in the food and technology field, as far as this study is concerned, it has not yet been exploring how consumers perceived and prepared to accept the changes from the present packaging, especially in monetary value. Previous studies as mentioned in the literature proved that consumers are keen towards any product that helps to improve the environmental problem; however, it is still ambiguous how they willing to trade off their daily expenditure on this innovation of bioplastic packaging.

Bioplastic is one of the sustainable packaging materials produced mainly from the by-product of agriculture and forestry sectors. It offers the food industry in the UK a new market to explore and another perspective to the consumers on the food packaging. The study aimed to examine and explore consumers' acceptance of innovation in sustainable packaging in the UK. For that purpose, this study examined how the consumer makes choices during the stated preference methods and how their environmental concern attitudes and perceptions affected WTP on bioplastic packaging. Moreover, this study also explored the views and thoughts of the local consumers towards the environmental problem and the insight of ideal sustainable packaging. The combination of environmental, psychological theory and economics has revealed valuable aspects of consumers' psychology reactions and purchasing behaviour. The results of the study are underpinned by theoretical of RUM and VBN on describing consumers' utility by trading off money with their satisfaction towards bioplastic food packaging.

The environmental psychology VBN model has illustrated how policymakers and the food industry can activate pro-environmental behaviour by purchasing this new

sustainable packaging. The SEM findings suggest that the environmentalism of an individual has influenced behaviour change towards acceptance of the packaging. Overall, the VBN latent variable of AC has shown the highest impact towards the WTP of bioplastic packaging in the SEM analysis. This identified that awareness of further consequences on the environment has positively encouraged respondents to purchase that packaging as pro-environmental behaviour. Furthermore, the BIO value was verified as the most important ecological value to generate a pro-environmental attitude among respondents. This environmental psychology outcome has provided insightful explanations of which factors of consumers do or do not give rise to the behavioural engagement of purchasing bioplastic packaging. Respondents' concerns and responsiveness on the effect of the environmental problem towards animals, plants and even humans carry relative weight in decision-making. The news on endangered species in the ocean, the build-up of solid waste and depletion of natural resources increases consumers' sense of responsibilities to protect the environment.

Informational strategies can be aimed at increasing consumers' awareness of environmental problems, their knowledge of the environmental impacts of their behaviour, and their perception of (dis)advantages of behavioural alternatives. However, De Groot and Steg (2009) stated that policymakers rarely try to promote reductions of environmental problems by stressing altruistic or biospheric interests. Promoting the information on altruistic or biospheric benefits of behaving pro-environmentally is important in increasing the saliency of environmental values and to strengthen their influence on the particular behaviour. The food producers and policymakers should highlight the benefit of choosing bioplastic packaging on the label. It is because someone most likely would act on the biospheric values when receiving information on why they should engage in specific pro-environmental actions (Steg & De Groot, 2012). For example, placing an ecological conservation story or an environmental membership of the company such as the Worldwide Fund on the package seems to add the value of the packaging to boost consumers' acceptance of the package. Such information is crucial to support people to act on their environmental values, which will make pro-environmental action more likely. Consumers who have a high consciousness of saving the environment and its well-being would buy or intend to buy the food product.

This research extends the knowledge of non-compensatory attributes of new sustainable packaging that respondents would certainly not willing to compromise with other attributes of food packaging. No previous study as far as this study is concerned has empirically examined the attribute cut-off violations of food packaging in the model

estimation. It is proven that the addition of attribute cut-offs violation parameters into the RUM has improved the model and lead to the definite prediction of the maximum utility satisfaction of respondents. The results find that some respondents tend to use attribute cut-offs in their decision regarding stated purchases of the food packaging. However, there are also some respondents that do not always adhere to their self-reported cut-off statements but willing to take a utility penalty rather than eliminate an alternative when a violation occurs. Moreover, the results find that those utility penalties associated with cut-offs violations vary considerably across packaging attributes. The results of two different ML models indicate that compared with ignoring cut-offs violation on full compensatory and incorporating the violation parameters into the compensatory model significantly improve model fit.

With cut-off violations in the WTP estimation, the model predicted that respondents were charged a utility penalty when violating their self-reported cut-off on the availability of bioplastic certification information and when choosing tree cellulose bioplastic packaging with reference to agricultural waste packaging. However, accounting on respondents' WTP on tree cellulose, which they are unlikely to spend more on that bioplastic, they would suffer more utility loss if they violated the agricultural waste cut-off statement. The results also indicated that respondents are most likely to suffer utility loss when violating their price cut-off statements. The results indicated that the price cut-off statement is the least violating cut-off if compared with other self-reported cut-off statements. Price seems the primary concern when introducing a new product in the market or rebranding with new packaging. According to Seo et al. (2016), consumers are willing to trade off almost all food product attributes in favour of protecting the environment, except for taste and price which will be the primary concern when choosing a product. Consumers' perceptions of sustainability are habitually related to inferences on other benefits, such as the product's taste and price.

The empirical evidence of ML estimation also suggests that agricultural waste has the larger potential as bioplastic material than tree cellulose, and the certified source of the material is certainly needed to be known by consumers on the label. Respondents are willing to spend £ 0.13 more on the transparency of certified bioplastic and £ 0.16 less if the packaging is made from tree cellulose. These two aspects of the source of bioplastic material and its information play a significant role in drawing the interest of consumers to bioplastic packaging and the contribution they made by buying it. It is corresponding to the social dimension of sustainable packaging where besides acting as packaging, it should be communicated well with consumers and provide

transparency for any question formulated about it. The findings also suggested that the biodegradable and recyclable aspects outweighed the compostable bioplastic packaging. This is probably due to the difficulty on the disposal bins or unpredictable weather condition in the UK which could strongly prone away the consumers from compostable packaging alternatives.

This study has identified different segments of consumer groups when examining their choice behaviour. Taken altogether, the results indicate that 'label-concerned' and 'compostable avoider' consumer groups are a high percentage among other segments. Again, labelling is crucially necessary to giving out information to the consumers; and interestingly, the compostable disposal option is the least favoured by one consumer group, but the group positively accepts recyclable and biodegradable materials. Compostable is probably an unfamiliar concept in the UK, whereas recyclable is more common. It would be plausible to focus more on recyclable and biodegradable bioplastic disposal options as the disposal facility is in place and well-known by the local consumers. It is still providing benefits for all actors in the supply chain such as producer, retailer and consumer. Moreover, it still consumes less fossil-fuel sources and less deposited waste into the landfill.

The findings signal the importance of utilising packaging as a platform for market planning in terms of segmentation, targeting and positioning. Given the growing environmental awareness among the consumers, information on sustainable packaging offers food producers the opportunity to become market orientated as they know which trending attributes are the most preferable to consumers. Food producers have a chance to use the bioplastic packaging as marketing tool for increasing a products commercial values.

The investigation proceeded to examine the potential characteristics of respondents that may be associated with the WTP of bioplastic packaging. The results found heterogeneity in respondents' WTP based on their household income, gender, family composition, age groups and additional knowledge on bioplastic. Not surprisingly, high household income respondents would be willing to spend more on agricultural waste bioplastic packaging than low and medium household income groups. This situation perceives that the marketing strategies in need to market new packaging to the high income consumers and refusal on that packaging from the majority of consumers can be expected in the future. In terms of age groups, older the respondents would trade off less than young respondents by £ 0.31 for agricultural waste bioplastic packaging. Understandably, this evidence supports the differences between the generations in

terms of accepting technology. Moreover, female respondents are keen to spend an extra £ 0.36 of their weekly expenditure to protect the environment and £ 0.56 more in the case of respondents with knowledge of bioplastic. It appears that female and advance knowledge profoundly contributes to the increase in the WTP. Furthermore, respondents with family with children are prepared to give up £ 1.32 extra to improve environmental problems of solid waste. This evidence enhances the understanding that female consumers are likely the responsible party to buy household groceries. Then, they would pay attention to the food product's information and read more about it. Moreover, logically, someone with children is plausibly caring more about how they manage the solid waste at home in comparison to the single consumer as they want to safeguard the clean environment for the children and be a role model to them. Providing more information on bioplastic packaging might be useful to increase consumer knowledge and gradually implement the packaging in the market. Therefore, consumers from all groups would be well-informed about the benefit of the packaging to protect nature. The investigation advanced to examine the affect of respondent's shopping habit for dairy milk on WTP of bioplastic milk packaging. It is found that milk preferences, milk procurement and disposal option had significantly impact on the WTP. To encourage more consumers to buy bioplastic milk packaging, food producers should implement recyclable bioplastic than other types of disposal options and build a more extensive and convenient distribution network around the country.

It is interesting to observe the implication of VBN-based constructs in the WTP of agricultural waste bioplastic food packaging. It was also found that biospheric values and respondents' awareness of the environmental problems has driven the intention to spend on bioplastic packaging. Consistent with the propositions of the previous VBN and SEM results, as the respondents expressed a higher level of awareness and biospheric values, they would be willing to buy that innovation. It is assumed that when their awareness increases on the impact of solid waste towards the environment, they tend to feel more responsible for engaging in pro-environmental behaviour. The CV analysis thus shows the importance of external factors such as personal characteristics, values and beliefs when it comes to decision-making in the product development process. Especially for a novel and only insufficiently explored topic such as bioplastics, this study suggests that it is not technological shortfalls or higher costs that cause hesitancy to act but rather the fear of not exercising full control over the outcomes of the action.

In the light of the results, a discussion on the pro-environmental behaviour towards purchasing the bioplastic packaging leads to a positive reaction during both qualitative

and quantitative methods. Although the industry needs to match the sustainable packaging design with consumers' personality or personal preferences, they seem prepared to trade off a significant amount of daily budget on that packaging. The level of environmental concern does have an impact on their pro-environmental purchasing behaviour. The new plant-based packaging material offers a new market to the food industry and probably would reduce the municipal solid waste, eventually. A large stream of consumer research suggests that consumers have a positive attitude toward more sustainable packaging, that packaging sustainability is relevant and salient to consumers, and that it can contribute to consumers' purchase likelihoods and willingness to pay. On the whole, the research on consumer perceptions of packaging sustainability suggests that sustainability attributes are desirable and have positive effects on consumer response.

Policymakers would also do well to recognise that the bio-based packaging industry in the UK is still unproven and largely unknown to consumers, so uncertainty and perceived risk will affect them when making decisions about bio-based claims. So, they need testing or certification standards for environmentally friendly packaging that they can trust. Considerations such as a product certification and labelling programme could serve as a policy tool to increase the consumer awareness of the environmental value proposition of bio-based products. If done effectively, this should help strengthen a nation's bio-based market. However, labelling practices need consistency and clarity, otherwise, they end up confusing consumers or misleading them. Certification grades could be established for manufacturers to then incorporate into their brand labels. Such grades, however, would only make sense if reliable testing or certification standards were available. Moreover, management support and increased infrastructure for recycling bioplastics and certifying biodegradability are likely to win more public support than initiatives whose benefits are less tangible to the consumer. The same applies to research advances that extend bioplastic biodegradability and recyclability. The policymakers should propose more policies favourable to food manufacturers or retailers that produce or use green packaging, to stimulate more corporations to go green in their manufacturing and operating activities.

Limitations of the study

Given the total outcomes of this study, it is not without limitations that need to be considered. The generalisability of the results is subject to at least three limitations spotted during the study. The limitations highlighted in this section lead to opportunities for further research. Firstly, the sample is limited to England only, and it only samples 565 individuals of the total population. Considering that the population is growing in the UK, it could be an extra advantage if there are comparison results within another part of the UK such as Wales, Scotland and Northern Ireland. The high level of sample profiles is another important element to be measured in the future. Even though this study applied quota sampling to match the total population, but it is limited to the age and gender of the total population. An additional sample profile such as educational level, household income or others may result differently or even precise of the utility maximisation in the future.

Besides the representative sample, the CE used as the context of this research presented four different attributes relating to the innovation in sustainable packaging. The use of technical terms might impact the decision-making choice for some respondents who have limited familiarity with those technical terms. Moreover, CE can incorporate different numbers of attributes within the presentation of choices and is likely that this degree of complexity might also impact the choice strategies employed by respondents. Therefore, this limitation provides the opportunity for further research within the same field, examining the impact of other ways of representing attributes and impact of using packaging terminology in the practice of a stated preference method.

Lastly, the third limitation is the presence of the non-compensatory questions in the questionnaire. It has been a debate on either to elicit those attribute cut-off sections before or after the CE in the literature. Some scholars mentioned it could be a good warm-up task for the respondent to familiar with attribute prior the CE by making them self-aware of self-preference and hopefully based on the past experiences and not on the information provided in the CE task itself; however, some would say it could lead to bias if placed before the choice task. Even though this study applied a post-choice non-compensatory task due to the difficulty of the new technical term, it could be an interesting aspect to be explored in the future. The relationship between these post-choice and pre-choice cut-off task might lead to the predictive ability of the models with respect to real choices and eventually, the ability to predict market behaviour better. Moreover, one weakness of Swait's non-compensatory approach is that a respondent's

self-reported cut-offs may not be exogenous to choices. The application of ML as an estimation model considered the taste variation of the individual; however, predicting cut-off violations based on personal characteristics does provide the way to investigate the concern of endogeneity. Future work may consider improving on the instruments for self-reported cut-offs by including more personal characteristics, such as the knowledge of each attribute or personality, into consideration.

References

- Adamowicz, W., Louviere, J. & Williams, M. (1994). Combining revealed and stated preference methods for valuing environmental amenities. *Journal of Environmental Economics & Management*. 26(3), 271-292.
- Adler, E.S. & Clark, R. (2011). *An Invitation to Social Research. How It's Done*. 4th Edition. Belmont, USA, Wadsworth Cengage Learning.
- Advisory Committee on Packaging (ACP) (2008) *Packaging in perspective*. Available from: <http://www.thefactsabout.co.uk/files/98201010542packaginginperspective.pdf> [Accessed 21st February 2017].
- Aggelakis, A.N. & Synder, S.A. 2015 Wastewater treatment and reuse: past, present and future. *Water*. 7, 4887-4895.
- Agustin, M.B., Ahmmad, B., Alonzo, S.M.M. & Patriana, F.M. (2014) Bioplastic based on starch and cellulose nanocrystals from rice straw. *Journal of Reinforced Plastics & Composites*. 33(24), 2205-2213.
- Aizaki, H., Sawada, M., Sato, K. & Kikkawa, T. (2012) A noncompensatory choice experiment analysis of Japanese consumers' purchase preferences for beef. *Applied Economics Letters*.19, 439-444.
- Aldridge, S. & Miller, L. (2012) *Why Shrinkwrap a Cucumber?: The Complete Guide to Environmental Packaging*. London, England, Laurence King Publishing.
- Allen, D. & Bakshani, N. (1992) Environmental impact of paper and plastic grocery sacks: a mass balance problem with multiple recycle loops. *Chemical Engineering Education*. 26(2), 82-86.
- Andrady, A. (2015) *Plastics and Environmental Sustainability*. Hoboken, New Jersey, John Wiley & Sons.
- Andrady, A.L. & Neal, M.A. (2009) Applications and societal benefits of plastics. *Philosophical Transactions of Royal Society B*. 364, 1977-1984.
- Arata, L., Guastella, G., Pareglio, S., Scarpa, R. & Sckokal, P. (2018) *Periurban agriculture: do the current EU agri-environmental policy programmes fit with it?* Fondazione Eni Enrico Mattei (FEEM) Working Paper 016.2018. Available at: https://www.feem.it/m/publications_pages/ndl2018-016.pdf.
- Auliandri, T.A., Thoyib, A., Rohman, F. & Rofiq, A. (2018) Does green packaging matter as a business strategy? exploring young consumers' consumption in an emerging market. *Problems & Perspectives in Management*. 16(2), 376-384.
- Balaguer, M.P., Villanova, J., Cesar, G., Gavara, R. & Hernandez-Munoz, P. (2015) Compostable properties on antimicrobial bioplastics based on cinnamaldehyde cross-links gliadins. *Chemical Engineering Journal*. 262, 447-455.
- Barnard, M. (2005) *Graphic Design as Communication*. Abingdon, England, Routledge.

- Barnes, A. (2017) Telling stories: the role of graphic design and branding in the creation of 'authenticity' within food packaging. *International Journal of Food Design*. 2(2), 183-202.
- Baruk, A.I. & Iwanicka, A. (2016) The effect of age, gender and level of education on the consumer's expectations towards dairy product packaging. *British Food Journal*. 118(1), 100-118.
- Bateman, I.J., Carson, R.T., Day, B., Hanemann, M., Hanley, N., Hett, T., Jones-Lee, M., Loomes, G., Mourato, S., Ozdemiroglu, E., Pearce, D.W., Sugden, R. & Swanson, J. (2002) *Economic Valuation with Stated Preference Technique. A manual*. Massachusetts, USA, Edward Elgar Publishing Inc.
- Bazeley, P. (2013) *Qualitative Data Analysis: Practical Strategies*. London, England, Sage Publications Ltd.
- Bazeley, P. & Jackson, K. (2014) *Qualitative Data Analysis with NVivo. Second Edition*. London, England, Sage Publications Ltd.
- Bearne, S. (2018) *Could plant-based plastics help tackle waste pollution?* Available from: <https://www.bbc.co.uk/news/business-42973529> [Accessed 27th January 2019].
- Beeharry, Y.D., Bekaroo, G., Bokhoree, C., Phillips, M.R. & Jory, N. (2017) Sustaining anti-littering behaviour within coastal and marine environments: through the macro-micro level lenses. *Marine Pollution Bulletin*. 119, 87-99.
- Bergstrom, J.C., Dillman, B.L. & Stroll, J.R. (1985) Public environmental amenity benefits of private land: the case of prime agricultural land. *Southern Journal of Agricultural Economics*. 17, 139-150.
- Benton Jr., R. (2015) Reduce, reuse, recycle and refuse. *Journal of Marcomarketing*. 35(1), 111-122.
- Berto, D., Rampazzo, F., Gion, C., Noventa, S., Ronchi, F., Traldi, U., Giorgi, A.M. & Giovanardi, O. (2017) Preliminary study to characterise plastic polymers using elemental analyser/isotope ratio mass spectrometry (EA/IRMS). *Chemosphere*. 176, 47-56.
- Bickerstaffe, J. (2000) Communicating with consumers about packaging. In: *Packaging Policy and the Environment*. Gaithersburg, Aspen Publisher Inc, pp. 102-113.
- Biswas, A. & Roy, M. (2015) Leveraging factors for sustained green consumption behaviour based on consumption value perceptions: testing the structural model. *Journal of Cleaner Production*. 95, 332-340.
- Bliemer, M.C. & Collins, A.T. (2016) On determining priors for the generation of efficient stated choice experimental design. *The Journal of Choice Modelling*. 21,10-14.
- Bliemer, M. & Rose, J. (2005) *Efficient designs for alternative specific choice experiments*. Sydney, Australia, Institute of Transport and Logistic Studies, University of Sydney.

- Bradley, M. & Daly, A. (1994) Use of the logit scaling approach to test for rank-order and fatigue effects in stated preference data. *Transportation*. 21(2), 167-184.
- Braungart, M., McDonough, W. & Bollinger, A. (2007) Cradle-to-cradle: creating healthy emissions - a strategy for eco-effective product and system design. *Journal of Cleaner Production*. 15(13), 1337-1348.
- Brunori, G. & Galli, F. (2016) Sustainability of local and global food chains: introduction to the special issue. *Sustainability*. 8(765), 1-7.
- Byrne, B.M. (2010) *Structural Equation Modeling with Amos. Basic Concepts, Applications and Programming*. 2nd ed. New York, USA, Routledge Taylor & Francis Group.
- Cantillo, V. & Ortuzar, J.D. (2006) Implications of thresholds in discrete choice modelling. *Transport Reviews*. 26(6), 667-691.
- Cameron, A.C. & Trivedi, P.K. (2010) *Microeconometrics Using Stata: Revised Edition*. 2nd ed. Texas, USA, Stata Press.
- Castellani, V., Sala, S. & Mirabella, N. (2015) Beyond the throwaway society: a life cycle-based assessment of the environmental benefit of reuse. *Integrated Environmental Assessment & Management*. 11(3), 373-382.
- Centre for Economics and Business Research (CEBR). (2015) *The future potential economic impacts of bio-plastics industry in the UK. A report for Bio-based and Biodegradable Industries Association (BBIA)*. Available from: <http://bbia.org.uk/wp-content/uploads/2015/11/BBIA-CEBR-Report.compressed.pdf> [Accessed 20th January 2018].
- Cheek, K.A. & Wansink, B. (2017) Making it part of the package: edible packaging is more acceptable to young consumers when it is integrated with food. *Journal of Food Products Marketing*. 23(6), 723-732.
- Chen, M.F. (2015) An examination of the Value-Belief-Norm theory model in predicting pro-environmental behaviour in Taiwan. *Asian Journal of Social Psychology*. 18, 145-151.
- Chen, Q., Anders, S. & An, H. (2013) Measuring consumer resistance to a new food technology: a choice experiment in meat packaging. *Food Quality & Preference*. 28, 419-428.
- Chartered Institution of Wastes Management (CIWM). (2016) *Packaging waste recovery - a European comparison*. Available from: <https://www.ciwm-journal.co.uk/downloads/Packaging-Waste-Recovery-A-European-comparison.pdf> [Accessed 8th September 2017].
- Coast, J. & Horrocks, S. (2007) Developing attributes and levels for discrete choice experiments using qualitative methods. *Journal of Health Services Research & Policy*. 12(1), 25-30.

- Collis, J. & Hussey, R. (2003) *Business Research: A Practical Guide for Undergraduate and Postgraduate Students*. 2nd ed. Basingstoke, USA, Palgrave Macmillan.
- Colwill, J., Wright, E. & Rahimifard, S. (2012) A holistic approach to design support for bio-polymer based packaging. *Journal of Polymers & the Environment*. 20(4), 1112-1123.
- Comerford, J.W., 2018. *How plastics made from plants could be the answer to the world's waste problem*. Available from: <http://theconversation.com/how-plastics-made-from-plants-could-be-the-answer-to-the-worlds-waste-problem-89475> [1st June 2018].
- Creusen, M. & Schoormans, J. (2005) The different roles of product appearance in consumer choice. *Journal of Product Innovation Management*. 22, 63-81.
- Dahlbo, H., Poliakova, V., Myllari, V., Sahimaa, O. & Anderson, R. (2018) Recycling potential of post-consumer plastic packaging waste in Finland. *Waste Management*. 71, 52-61.
- Daly, A., Hess, S. & Train, K. (2012) Assuring finite moments for willingness to pay in random coefficient models. *Transportation*. 39, 19-31.
- Dangelico, R.M. & Pontrandolfo, P. (2010) From green product definitions and classifications to the Green Option Matrix. *Journal of Cleaner Production*. 18, 1608-1628.
- Debus, M. (2007) *A Handbook for Excellence in Focus Group Research*. Washington DC, USA, Academy for Educational Development.
- De Bekker-Grob, E., Donkers, B., Jonker, M.F. & Stolk, E.A. (2015) Sample size requirements for discrete-choice experiments in healthcare: a practical guide. *Patient*. 8, 373-384.
- De Groot, J. & Steg, L. (2008) Value orientations to explain beliefs related to environmental significant behaviour. How to measure egoistic, altruistic, and biospheric value orientations. *Environment & Behaviour*. 40(3), 330-354.
- De Groot, J. & Steg, L. (2007) Value orientations and environmental beliefs in five countries: validity of an instrument to measure egoistic, altruistic and biospheric value orientations. *Journal of Cross-Cultural Psychology*. 38, 318-332.
- De Groot, J. & Steg, L. (2009). Mean or green: which values can promote stable pro-environmental behaviour? *Conservation Letters*. 2, 61-66.
- DeShazo, J.R. & Fermo, G. (2002) Designing choice sets for stated preference methods: the effects of complexity on choice consistency. *Journal of Environmental Economics & Management*. 44(1), 123-143.
- Ding, Y., Veeman, M.M. & Adamowicz, W.L. (2012) The influence of attribute cutoffs on consumers' choices of a functional food. *European Review of Agricultural Economics*. 39(5), 745-769.

- Dixon-Hardy, D.W. & Curran, B.A. (2009) Types of packaging waste from secondary sources (supermarkets) - the situation in the UK. *Waste Management*. 29, 1198-1207.
- Dunlap, R. & Jones, R. (2002) Environmental concern: conceptual and measurement issues. In: Dunlap, R.E. & Michelson, W. (eds.) *Handbook of Environmental Sociology*. Westport, USA, Greenwood Press, pp. 482-524.
- Dunlap, R., Van Liere, K., Mertig, A. & Jones, R. (2000) Measuring endorsement of the new ecological paradigm: a revised NEP scale. *Journal of Social Issues*. 56, 425-442.
- Eldesouky, A., Pulido, A. & Mesias, F. (2015) The role of packaging and presentation format in consumers' preferences for food: an application of projective techniques. *Journal of Sensory Studies*. 30(5), 360-369.
- Elrod, T., Johnson, R.D. & White, J. (2004) A new integrated model of noncompensatory and compensatory decision strategies. *Organisational Behaviour & Human Decision Processes*. 95(1), 1-19.
- Environmental Agency. (2014) *Producer responsibility regulations*. Available from: <https://www.gov.uk/government/collections/producer-responsibility-regulations> [Accessed 23rd January 2019].
- Envirowise. (2002) *Packaging Design for the Environment: Reducing Costs and Quantities*. Harwel International Business Centre. Report number: GG360.
- European Bioplastics (2012) *Accountability is key. Environmental communication guide for bioplastics*. Available from: https://www.adhesives.org/docs/pdfs/eubp_environmental_communications_guide_2012_final.pdf?sfvrsn=211e5b6d_0 [Accessed 21st September 2018].
- European Commission. (2014) *Attitudes of Europeans towards waste management and resource efficiency*. European Union. Report number: Flash Eurobarometer 388.
- Eurostat. (2012) *Landfill still accounted for nearly 40% of municipal waste treated in the EU27 in 2010*. Available from: <https://ec.europa.eu/eurostat/documents/2995521/5149994/8-27032012-AP-EN.PDF/c97de335-d005-478d-a6fc-9f14bc78bfd5> [Accessed 24th January 2019].
- Eurostat. (2016) *Development of all packaging waste generated, recovered and recycled, EU, 2007-2016*. Available from https://ec.europa.eu/eurostat/statistics-explained/index.php/Packaging_waste_statistics [Accessed 6th January 2019].
- Ercilla-Montserrat, M., Sanjuan-Delmas, D., Sanye-Mengual, E., Calvet-Mir, L., Banderas, K., Rieradevall, J. & Gabarrell, X. (2019) Analysis of consumer's perception of urban food products from a soilless system in rooftop greenhouse: a case study from the Mediterranean area of Barcelona (Spain). *Agriculture & Human Values*. 1-19.
- FAO. (2013) *Milk and dairy products in human nutrition*. Available from <http://www.fao.org/3/i3396e/i3396e.pdf> [Accessed 20th June 2017].
- Fernandes, A.N., Thomas, L.H., Altaner, C.M., Callow, P., Forsyth, T., Apperley, D.C., Kennedy, C.J. & Jarvis, M.C. (2011) Nanostructure of cellulose microfibrils in spruce

- wood. *Proceedings of the National Academy of Sciences of the United States of America*. 108(47), 1195-1203.
- Fernie, J. & Hart, C. (2001) UK packaging waste legislation. Implications for food retailers. *British Food Journal*. 103(3), 187-197.
- Ferreira da Cruz, N., Ferreira, S., Cabral, M., Simoes, P. & Marques, R.C. (2014) Packaging waste recycling in Europe: is the industry paying for it? *Waste Management*. 34, 298-308.
- Forbes-Brown, S., Micheels, E.T. & Hobbs, J.E. (2016) Consumer willingness to pay for dairy products with the 100% Canadian Milk label: A discrete choice experiment. *Journal of International Food & Agribusiness Marketing*. 28(3), 203-224.
- Gall, M., Borg, W. & Gall, J. (2002) *Educational Research: An Introduction. 7th edition*. New York, USA, Longman.
- Galley, M., Elton, E. & Haines, V. (2005) Packaging: a box of delights or a can of worms? The contributions of ergonomics to the usability, safety and semantics of packaging. In: FaraPack Briefing 2005: New Technologies for Innovative Packaging, 12 - 13 October 2005, Loughborough's Institutional Repository.
- Garcia-Llorente, M., Martin-Lopez, B., Nunes, P.A., Gonzalez, J.A., Alcorlo, P. & Montes, C. (2011) Analysing the social factors that influence willingness to pay for invasive alien species management under two different strategies: eradication and prevention. *Environmental Management*. 48(3), 418-435.
- Garton, L., Haythornthwaite, C. & Wellman, B. (1999) Studying on-line social networks. In: Jones, S. *Doing Internet Research: Critical Issues and Methods for Examining the Net*. California, USA, Thousand Oaks, Sage, pp. 75-105.
- Gelici-Zeko, M.M., Lutters, D., Klooster, R. & Weijzen, P.L.G. (2013) Studying the influence of packaging design on consumer perceptions (of dairy products) using categorising and perceptual mapping. *Packaging Technology & Science*. 26, 215-228.
- Ghenai, C. (2012) Life cycle assessment of packaging materials for milk and dairy products. *International Journal of Thermal and Environmental Engineering*. 4(2), 117-128.
- Ghosh, B.K. (2016) Impact of packaging on consumers' buying behaviour. A case study of Mother Dairy, Kolkata. *KIIT Journal of Management*. 12(2), 27-34.
- Giancristofaro, R.A. & Bordignon, P. (2016) Consumer preferences in food packaging: CUB models and conjoint analysis. *British Food Journal*. 118(3), 527-540.
- Gomez-Heincke, D., Martinez, I., Stading, M. & Gallegos, C. (2017) Improvement of mechanical and water absorption properties of plant protein based bioplastics. *Food Hydrocolloids*. 73, 21-29.
- Grether, D. & Wilde, L. (1984) An analysis of conjunctive choice: theory and experiments. *The Journal of Consumer Research*. 10(4), 373-385.

- Gronman, K., Soukka, R., Jarvi-Kaariainen, T., Katajajuuri, J., Kuisma, M., Koivupuro, H., Ollila, M., Pitkanen, M., Miettinen, O., Silvenius, F., Thun, R., Wessman, H. & Linnanen, L. (2013) Framework for sustainable food packaging design. *Packaging Technology & Science*. 26, 187-200.
- Grunert, K., Hieke, S. & Wills, J. (2014) Sustainability labels on food products: consumer motivation, understanding and use. *Food Policy*. 44, 177-189.
- Guillard, V. & Roux, D. (2014) Macromarketing issues on the sidewalk: how "gleaners" and "disposer" (re)create a sustainable economy. *Journal of Macromarketing*. 34(3), 291-312.
- Gyekye, L. (2013) *Nampak unveils 'world's first' milk bottle to contain 30% recycled HDPE*. Available from <https://www.packagingnews.co.uk/news/nampak-unveils-worlds-first-milk-bottle-to-contain-30-recycled-hdpe-15-05-2013> [Accessed 2 June 2018].
- Haab, T. & McConnell, K. (2002) *Valuing Environmental and Natural Resources: The Econometrics of Non-market Valuation*. Northampton, England, Edward Elgar.
- Hakim, C. (2000) *Research Design: Successful Designs for Social and Economic Research*. 2nd ed. London, England, Routledge.
- Hanemann, M., Loomis, J. & Kanninen, B. (1991) Statistical efficiency of double-bounded dichotomous choice contingent valuation. *American Journal of Agricultural Economics*, 1255-1263.
- Hauser, J.R., Ding, M. & Gaskin, S.P. (2009) Non-compensatory (and compensatory models of consideration-set decisions. *Proceedings of the Sawtooth Software Conference 23-27 March 2009, Florida, USA*. pp. 1-32.
- Hawcroft, L.J. & Milfont, T.L. (2010) The use (and abuse) of the new environmental paradigm scale over the last 30 years: a meta-analysis. *Journal of Environmental Psychology*. 30, 143-158.
- Hensher, D.A., Rose, J.M. & Greene, W.H. (2015) *Applied Choice Analysis*. 2nd ed. Cambridge, England, Cambridge University Press.
- Herbes, C., Beuthner C. & Ramme, I. (2018) Consumer attitudes towards biobased packaging - a cross-cultural comparative study. *Journal of Cleaner Production*. 194, 203-218.
- Hermann, B.G., Blok, K. & Patel, M.K. (2010) Twisting biomaterials around your little finger: environmental impacts of bio-based wrappings. *International Journal of Life Cycle Assessment*. 15, 346-358.
- Hoek, A.C., Pearson, D., James, S.W., Lawrence, M.A. & Friel, S. (2017) Healthy and environmentally sustainable food choices: consumer responses to point-of-purchase actions. *Appetite*, 58, 94-106.
- Hoffenson, S., Dagman, A. & Soderberg, R. (2015) Visual quality and sustainability considerations in tolerance optimisation: a market-based approach. *International Journal of Production & Economics*. 168, 167-180.

- Hole, A.R. & Kolstad, J.R. (2012) Mixed logit estimation of willingness to pay distributions: a comparison of models in preference and WTP space using data from a health-related choice experiment. *Empirical Economics*. 42, 445-469.
- Hollins, O. (2013) *Overview of waste in the UK hospitality and food service sector*. Available from: <http://www.wrap.org.uk/sites/files/wrap/Overview%20of%20Waste%20in%20the%20UK%20Hospitality%20and%20Food%20Service%20Sector%20FINAL.pdf> [Accessed 8th September 2018].
- Hopewell, J., Dvorak, R. & Kosior, E. (2009) Plastics recycling: challenges and opportunities. *Philosophical Transactions of the Royal Society B*. 364, 2115-2126.
- Hox, J. & Bechger, T. (1998) An introduction to structural equation modelling. *Family Science Review*. 11, 354-373.
- Hu, L.T. & Bentler, P.M. (1999) Cutoff criteria for fit indexes in covariance structure analysis: conventional criteria versus new alternatives. *Structural Equation Modeling: A Multidisciplinary Journal*, 6(1), 1-55.
- Huber, J. & Klein, N.M. (1991) Adapting cutoffs to the choice environment: the effects of attribute correlation and reliability. *The Journal of Consumer Research*, 18(3), 240-408.
- Ibtissem, M.H. (2010) Application of value beliefs norms theory to the energy conservation behaviour. *Journal of Sustainable Development*. 3(2), 129-139.
- Israel, G.D. (1992) *Determining sample size*. Available from: http://sociology.soc.uoc.gr/socmedia/papageo/metapyxiakoi/sample_size/samplesize1.pdf [Accessed 20th June 2018].
- Jambeck, J.R., Geyer, R., Wilcox, C., Siegler, T.R., Perryman, M., Andrady, A., Narayan, R. & Law, K.L. (2015) Plastic waste inputs from land into the ocean. *Science*, 347(6223), 768-771.
- Jansson, J., Marell, A. & Nordlund, A. (2011) Exploring consumer adoption of a high involvement eco-innovation using value-belief-norm theory. *Journal of Consumer Behaviour*. 10, 51-60.
- Jayanth, D., Kumar, P.S., Nayak, G.C., Kumar, J.S., Pal, S.K. & Rajasekar, R. 2018. A review on biodegradable polymeric materials striving towards the attainment of green environment. *Journal of Polymers & the Environment*. 26, 838-865.
- Jerzyk, E. (2015) Sustainable packaging as a determinant of the process of making purchase decisions from the perspective of Polish and French young consumers. *Journal of Agribusiness & Rural Development*. 3(37), 437-445.
- Jerzyk, E. (2016) Design and communication of ecological content on sustainable packaging in young consumers' opinions. *Journal of Food Products Marketing*. 1-10.

- Jimenez-Guerrero, J.F., Gazquez-Abad, J.C. & Ceballos-Santamaria, G. (2015) Innovation in eco-packaging in private labels. *Innovation: Management, Policy & Practice*. 17(1), 81-90.
- Jinkarn, T. & Suwannaporn, P. (2015) Trade-off analysis of packaging attributes for foods and drinks. *British Food Journal*. 117(1), 139-156.
- Johnson, R. & Desvousges, W. (1997) Estimating stated preferences with rated-pair data: environmental, health, and employment effects of energy programs. *Journal of Environmental Economics & Management*. 34(1), 79-99.
- Joreskog, K.G. (1993) Testing structural equation models. In: Bollen, K.A. & Long, J.S. *Testing Structural Equation Models*. Newbury Park, California, USA, Sage, pp. 294-316.
- Kassaye, W. & Verma, D. (1992) Balancing traditional packaging functions with the new 'green' packaging concerns. *SAM Advanced Management Journal*. 57(4), 15.
- Kalkowski, J. (2007) State of 'green packaging'. *Packaging Digest*. 44(12), 40.
- Kaye-Blake, W.H., Abell, W.L. & Zellman, E. (2009) Respondents' ignoring of attribute information in a choice modelling survey. *Australian Journal of Agriculture Resource and Economic*. 53(4), 547-564.
- Keizer, K. (2008) The spreading of disorder. *Science*. 322(1681).
- Klein, N. & Bither, S. (1987) An investigation of utility-directed cutoff selection. *Journal of Consumer Research*. 14, 240-256.
- Kijchavengkul, T. & Auras, R. (2008) Perspective compostability of polymers. *Polymer International*. 57, 793-804.
- Klojgaard, M.E., Bech, M. & Sogaard, R. (2012) Designing a stated choice experiment: the value of a qualitative process. *Journal of Choice Modelling*. 5(2), 1-18.
- Kock, N. & Lynn, G.S. (2012) Lateral collinearity and misleading results in variance-based SEM: an illustration and recommendations. *Journal of the Association for Information Systems*. 13(7), 546-580.
- Koenig-Lewis, N., Palmer, A., Dermody, J. & Urbye, A. (2014) Consumers' evaluations of ecological packaging-rational and emotional approaches. *Journal of Environmental Psychology*. 37, 94-105.
- Kopacic, S., Walzl, A., Zankel, A., Leitner, E. & Bauer, W. (2018) Alginate and chitosan as a functional barrier for paper-based packaging materials. *Coatings*. 7(8), 1-15.
- Krueger, R.A. & Casey, M.A. (2015) *Focus Group. A Practical Guide for Applied Research* 5th ed. London, UK, Sage Publications Ltd.
- Kuhl, S., Gassler, B. & Spiller, A. (2017) Labelling strategies to overcome the problem of niche markets for sustainable milk products: the example of pasture-raised milk. *Journal of Dairy Science*. 100(6), 5082-5095.

- Lancaster, K.J. (1966) A new approach to consumer theory. *Journal of Political Economy*. 74(2), 132-157.
- Lancsar, E. & Louviere, J. (2008) Conducting discrete choice experiments to inform health care decision making: a user's guide. *Pharmacoeconomics*. 26(8), 661-677.
- Lau, O. & Wong, S. (2000) Contamination in food from packaging materials. *Journal of Chromatography A*. 882(1/2), 255-270.
- Laureati, M., Jabes, D., Russo, V. & Pagliarini, E. (2013) Sustainability and organic production: how information influences consumer's expectation and preference for yoghurt. *Food Quality & Preference*. 30, 1-8.
- Lehtinen, U. (2012) Sustainability and local food procurement: a case study of Finnish public catering. *British Food Journal*. 114(8), 1053-1071.
- Lemken, D., Knigge, M., Meyerding, S. & Spiller, A. (2017) The value of environmental and health claims on new legume products: a non-hypothetical online auction. *Sustainability*. 9(1340), 1-18.
- Lewis, H. (2008) Eco-design of food packaging materials. In: Chiellini, E. *Environmentally Compatible Food Packaging*. Cambridge, UK, Woodhead Publishing, pp. 238 - 259.
- Liamputtong, P. (2011) *Focus Group Methodology: Principles and Practice*. 1st Edition ed. USA, Sage Publications Inc.
- Liang, X., Sun, C., Chen, B., Du, K., Yu, T., Luang-In, V., Lu, X. & Shao, Y. (2018) Insect symbionts as valuable grist for the biotechnological mill: an alkaliphilic silkworm gut bacterium for efficient lactic acid production. *Applied Microbiology & Biotechnology*. 102, 4951-4962.
- Lindh, H., Olsson, A. & Williams, H. (2016) Consumer perceptions of food packaging: contributing to or counteracting environmentally sustainable development? *Packaging Technology & Science*. 29(1), 3-23.
- Lindh, H., Williams, H., Olsson, A. & Wikstrom, F. (2016) Elucidating the indirect contributions of packaging to sustainable development: a terminology of packaging functions and features. *Packaging Technology & Science*, 29(5), 225-246.
- Liu, Q. & Zhou, J. (2017) Consumer choices and motives for eco-labelled products in China: an empirical analysis based on the choice experiment. *Sustainability*. 9(331), 1-12.
- Lofgren, M. & Witell, L. (2005) Kano's theory of attractive quality and packaging. *Quality Management Journal*. 12(3), 7-20.
- Lofgren, M., Witell, L. & Gustafsson, A. (2011) Theory of attractive quality and life cycles of quality attributes. *TQM Journal*. 23(2), 235-246.

- Lopez-Rubio, A., Almenar, E., Hernandez-Munoz, P., Lagaron, J.M., Catala, R. & Gavara, R. (2004) Overview of active polymer-based packaging technologies for food application. *Food Reviews International*. 20(4), 357-387.
- Louviere, J.J., Hensher, D.A. & Swait, J.D. (2000) *Stated Choice Methods. Analysis and Applications*. Cambridge, England, Cambridge University Press.
- Luckachan, G.E. & Pillai, C. (2011) Biodegradable polymers - a review on recent trends and emerging perspectives. *Journal of Polymer and Environment*.19, 637-676.
- Lynch, D.H., Klaassen, P. & Broerse, J.E. (2017) Unraveling Dutch citizens' perceptions on the bio-based economy: the case of bioplastics, bio-jetfuels and small-scale bio-refineries. *Industrial Crops & Products*. 106, 130-137.
- Lynch, J. G. & Ariely, D. (2000) Wine online: search costs affect competition on price, quality and distribution. *Marketing and Science*. 19(1), 83-103.
- Maddala, G.S. (1983) *Limited Dependent and Qualitative Variables in Econometrics*. Cambridge, England, Cambridge University Press.
- Madushanka, G. & Ragel, V.R. (2016) Consumer's attitude towards green packaging: a study on Trincomalee District. *SEUSL Journal of Marketing*. 1(2), 18-27.
- Magnier, L. & Crie, D. (2015) Communicating packaging eco-friendliness: an exploration of consumers' perceptions of eco-designed packaging. *International Journal of Retail & Distribution Management*. 43(4/5), 350-366.
- Magnier, L. & Schoormans, J. (2015) Consumer reactions to sustainable packaging: the interplay of visual appearance, verbal claim and environmental concern. *Journal of Environmental Psychology*. 44, 53-62.
- Magnier, L. & Schoormans, J. (2017) How do packaging material, colour and environmental claim influence package, brand and product evaluations? *Packaging Technology & Science*. 30, 735-751.
- Magnier, L., Schoormans, J. & Mugge, R. (2016) Judging a product by its cover: packaging sustainability and perceptions of quality in food products. *Food Quality & Preference*. 53, 132-142.
- Marsh, K. & Bugusu, B. (2007) Food packaging - roles, materials and environmental issues. *Journal of Food Science*. 72(3), 39-55.
- Martinho, G., Pires, A., Portela, G. & Fonseca, M. (2015) Factors affecting consumers' choices concerning sustainable packaging during product purchase and recycling. *Resources, Conservation & Recycling*. 103, 58-68.
- Martin-Lopez, B., Montes, C. & Benayas, J. (2007) Influence of user characteristics on valuation of ecosystem services in Donana natural protected area (south-west Spain). *Environmental Conservation*. 34, 215-224.
- Matin, A.H., Goddard, E., Vandermoere, F., Blanchemanche, S., Bieberstein, A., Marette, S. & Roosen, J. (2012) Do environmental attitudes and food technology

neophobia affect perceptions of the benefits of nanotechnology?. *International Journal of Consumer Studies*. 36, 149-157.

Matsueda, N. & Nagase, Y. (2012) An economic analysis of the packaging waste recovery note system in the UK. *Resource & Energy Economics*. 34, 669-679.

Mazzanti, M. & Zoboli, R. (2008) Waste generation, waste disposal and policy effectiveness. Evidence on decoupling from the European Union. *Resources, Conservation & Recycling*. 52, 1221-1234.

McFadden, D. (1974) Conditional logit analysis of qualitative choice behaviour. In: Zarembka, P. *Frontiers in Econometrics*. New York, USA, Academic Press, pp. 105-142.

McFadden, D. (1986) The choice theory approach to market research. *Marketing Science*. 5(4), 275-297.

McFadden, D. (2001) Economic choices. *The American Economic Review*. 91(3), 351-378.

McWilliams, A., Siegel, D.S. & Wright, P.M. (2006) Corporate Social Responsibility: Strategic Implications. *Journal of Management Studies*. 43(1), 1-18.

Meikle, J. (2009) *Fast food firms taken to task after survey of street litter*. Available from: <https://www.theguardian.com/business/2009/jan/13/fast-food-litter-mcdonalds-greggs> [Accessed 12th October 2018].

Meise, J., Rudolph, T., Kenning, P. & Phillips, D. (2014) Feed them facts: value perceptions and consumer use of sustainability-related product information. *Journal of Retailing & Consumer Services*. 21, 510-519.

Meurer, I.R., Lange, C.C., Hungaro, H.M., Bell, M.J.V., dos Anjos, V.C., Sa' Silva, C.A. & Pinto, M.A.O. (2017) Quantification of whole ultra-high temperature UHT milk waste as a function of packages type and design. *Journal of Cleaner Production*. 153, 483-490.

Mitchell, R.C. & Carson, R.T. (1989) *Using Surveys to Value Public Goods. The Contingent Valuation Method*. Washington, USA, Resources for the Future.

Mitchell, B., Topic, M. & Munroe, O. (2018) *Product and packaging innovation. Attitudes, behaviours, and strategies for sustainable packaging*. Available from: http://eprints.leedsbeckett.ac.uk/5188/1/ProductandPackagingInnovation_AttitudesBehavioursandStrategiesPV-TOPIC.pdf [Accessed 2nd January 2019].

Molina-Besch, K., Wikstrom, F. & Williams, H. (2018) The environmental impact of packaging in food supply chains - does life cycle assessment of food provide the full picture? *The International Journal of Life Cycle Assessment*. 24(1), 1-14.

Moser, R. & Raffaelli, R. (2014) Does attribute cut-off elicitation affect choice consistency? Contrasting hypothetical and real-money choice experiments. *The Journal of Choice Modelling*. 11, 16-29.

- Mores, G.d.V., Finocchio, C.P.S., Barichello, R. & Pedrozo, E.A. (2018) Sustainability and innovation in the Brazilian supply chain of green plastic. *Journal of Cleaner Production*. 177, 12-18.
- Nellemann, C. & Corcoran, E. (2006) *Our precious coasts - marine pollution, climate change and resilience of coastal ecosystems*. Norway, United Nation Environment Programme, GRID-Arendal. Available from: https://gridarendal-website-live.s3.amazonaws.com/production/documents/s_document/245/original/our-precious-coasts_lr.pdf?1487690389 [Accessed 31st January 2019].
- Nerin, C. (2008) Recycled paper and board for food applications: improving safety and quality. In: Chiellini, E. *Environmentally Compatible Food Packaging*. Cambridge, England, Woodhead Publishing Limited, pp. 351-368.
- Neill, C.L. & Williams, R.B. (2016) Consumer preference for alternative milk packaging: the case of an inferred environmental attribute. *Journal of Agricultural and Applied Economics*. 48(3), 241-256.
- Nielsen. (2014) *Global consumers are willing to put their money where their heart is when it comes to goods and services from companies committed to social responsibility*. Available from: <https://www.nielsen.com/us/en/press-room/2014/global-consumers-are-willing-to-put-their-money-where-their-heart-is.html> [Accessed 5th June 2018].
- Nordin, N. & Selke, S. (2010) Social aspect of sustainable packaging. *Packaging Technology & Science*. 23, 317-326.
- Nordlund, A. & Garvill, J. (2002) Value structures behind proenvironmental behaviour. *Environment & Behaviour*. 34, 740-756.
- Nuttavuthisit, K. & Thorgersen, J. (2017) The importance of consumer trust for the emergence of a market for green products: the case of organic food. *Journal of Business Ethics*. 140(2), 323-337.
- Okuda, I. & Thomson, V. (2007) Regionalization of municipal solid waste management in Japan: balancing the proximity principle with economic efficiency. *Environmental Management*. 40, 12-19.
- Onel, N. & Mukherjee, A. (2015) Understanding environmentally sensitive consumer behaviour: an integrative research perspective. *World Journal of Entrepreneurship, Management and Sustainable Development*. 11, 2-16.
- Onwezen, M.C., Reinders, M.J. & Sijtsema, S.J. (2017) Understanding intentions to purchase bio-based: the role of subjective ambivalence. *Journal of Environmental Psychology*. 52, 26-36.
- Othman, S. (2014) Bio-nanocomposites materials for food packaging applications: types of biopolymer and nano-sized filler. *Agriculture & Agricultural Science Procedia*. 2, 296-303.

- Orzan, G., Cruceru, A.F., Balaceanu, C.T. & Chivu, R. (2018) Consumers' behaviour concerning sustainable packaging: an exploratory study on Romanian consumers. *Sustainability*. 10 (1787), 1-11.
- Patton, M.Q. (2002) *Qualitative Research & Evaluation Methods*. 3rd Edition ed. USA, Sage Publication Inc.
- Park, J. & Ha, S. (2012) Understanding pro-environmental behaviour. A comparison of sustainable consumers and apathetic consumers. *International Journal of Retail & Distribution Management*. 40(5), 388-403.
- Payne, J., Bettman, J. & Johnson, E. (1992) Behavioural decision research: a constructive processing perspective. *Annual Review of Psychology*. 43, 87-131.
- Peelman, N., Ragaert, P., Vandemoortele, A., Verguldt, E., De Meulenaer, B. & Devlieghere, F. (2014) Use of biobased materials for modified atmosphere packaging of short and medium shelf-life food product. *Innovative Food Science & Emerging Technologies*. 26, 319-329.
- Piergiovanni, L. & Limbo, S. (2015) Metal packaging materials. In: Piergiovanni, L. & Limbo, S. *Food Packaging Materials*. New York, USA, Springer, pp. 13-22.
- Plimmer, J. (2013) Augmenting and securing the consumer brand experience through smart and intelligent packaging for food, beverages and other fast-moving consumer goods. In: Falmer, N. *Trends in Packaging of Food, Beverages and Other Fast-moving Consumer Goods (FMCG): Markets, materials and technologies*. Cambridge, England, Woodhead Publishing Limited, p. 35-56.
- Prakash, G. & Pathak, P. (2017) Intention to buy eco-friendly packaged products among young consumers of India: a study on developing nation. *Journal of Cleaner Production*. 141, 385-393.
- Povoledo, E. (2018) *Biodegradable bags cause outrage in Italy. (It's not really about bags)*. Available from: <https://www.nytimes.com/2018/01/08/world/europe/italy-plastic-bags.html> [Accessed 6 June 2018].
- Qureshi, W. (2015) *Nampak calls for recycled plastic support following Closed Loop woes*. Available from: <https://www.packagingnews.co.uk/news/materials/rigid-plastics/nampak-calls-recycled-21-04-2015> [Accessed 16th June 2018].
- Radulescu, D.M. & Radulescu, V. (2012) Ecological responsibility - part of sustainable development. *International Journal of Academic Research in Economics & Management Sciences*. 1(6), 89 - 96.
- Rebouillat, S. & Pla, F. (2013) State of the art manufacturing and engineering of nanocellulose: a review of available data and industrial applications. *Journal of Biomaterials & Nanobiotechnology*. 4(2), 165-188.
- Riberio, A.P.L., Carneiro, J.D.S., Ramos, T.D.M., Patterson, L. & Pinto, S.M. (2018) Determining how packaging and labelling of Requeijao cheese affects the purchase

- behaviour of consumers of different age groups. *British Food Journal*. 120(6), 1183-1194.
- Richter, B. (2017) Knowledge and perception of food waste among German consumers. *Journal of Cleaner Production*. 166, 641-648.
- Robertson, G. (1990) Good and bad packaging: who decides?. *International Journal of Physical Distribution & Logistics Management*. 20(8), 37-41.
- Rokka, J. & Uusitalo, L. (2008) Preference for green packaging in consumer product choices - do consumers care?. *International Journal of Consumer Studies*. 32(5), 516-525.
- Roper, S. & Parker, C. (2013) Doing well by doing good: a quantitative investigation of the litter effect. *Journal of Business Research*. 66, 2262-2268.
- Russo, I., Confente, I., Scarpi, D. & Hazen, B.T. (2019) From trash to treasure: the impact of consumer perception of bio-waste products in closed-loop supply chains. *Journal of Cleaner Production*. 218, 966-974.
- Sagnelli, D., Hebelstrup, K.H., Leroy, E., Rolland-Sabate, A., Guilois, S., Kirkensgaard, J.J.K., Mortensen, K., Lourdin, D., & Blennow, A. (2016) Plant-crafted starches for bioplastic production. *Carbohydrate Polymers*. 152, 398-408.
- Sagnelli, D., Hooshmand, K., Kemmer, G.C., Kirkensgaard, J.J.K, Mortensen, K., Giosafatto, C.V.L., Holse, M., Hebelstrup, K.H., Bao, J., Stelte, W., Bjerre, A. & Blennow, A. (2017) Cross-linked amylose bioplastic: a transgenic-based compostable plastic alternative. *International Journal of Molecular Sciences*.18(2075),1-12.
- Saldana, J. (2016) *The Coding Manual for Qualitative Researchers*. 3rd Edition. London, UK, Sage Publications Ltd.
- Sauer, U. & Fischer, A. (2010) Willingness to pay, attitudes and fundamental values - on the cognitive context of public preferences for diversity in agricultural landscapes. *Ecological Economics*. 70, 1-9.
- Saunders, M., Lewis, P. & Thornhill, A. (2007) *Research Methods for Business Students*. 4th ed. Essex, England, Pearson.
- Schlegelmilch, B.B., Bohlen, G.M. & Diamantopoulos, A. (1996) The link between green purchasing decisions and measures of environmental consciousness. *European Journal of Marketing*. 30(5), 35-55.
- Schmidt, L., Horta, A., Correia, A. & Fonseca, S. (2014) Generational gaps and paradoxes regarding electricity consumption and saving. *Nature & Culture*. 9(2), 183-203.
- Schultz, P.W., Bator, R.J., Large, L.B., Bruni, C.M. & Tabanico, J.J. (2013) Littering in context: personal and environmental predictors of littering behaviour. *Environment & Behaviour*. 45(1), 35-59.

- Secondi, L., Principato, L. & Laureti, T. (2015) Household food waste behaviour in EU-27 countries: a multilevel analysis. *Food Policy*. 56, 25-40.
- Seo, S., Ahn, H.K., Jeong, J. & Moon, J. (2016) Consumers' attitude towards sustainable food products: ingredients vs packaging. *Sustainability*. 8(1073), 1-19.
- Sethuraman, R., Cole, C. & Jain, D. (1994) Analyzing the effect of information format and task on cutoff search strategies. *Journal of Consumer Psychology*. 3(2), 103-136.
- Sheffield, H. (2016) *How to stop Christmas waste and the thousand of tonnes thrown away each year*. Available from: <https://www.independent.co.uk/environment/how-to-stop-christmas-waste-and-the-thousand-of-tonnes-thrown-away-each-year-a7489766.html> [Accessed 20th October 2018].
- Shin, J. & Selke, S.E. (2014) Food packaging. In: Clark, S., Jung, S. & Lamsal, B. *Food Processing: Principles and Applications 2nd Edition*. Oxford, UK, John Wiley & Sons, Ltd., pp. 249-271.
- Singh, G. & Pandey, N. (2018) The determinants of green packaging that influence buyers' willingness to pay a price premium. *Australasian Marketing Journal*. 26, 221-230.
- Silva, D.A.L., Reno, G.W.S., Sevegnani, G., Sevegnani, T.B. & Truzzi, O.M.S. (2013) Comparison of disposable and returnable packaging: a case study of reverse logistics in Brazil. *Journal of Cleaner Production*. 47, 377-387.
- Silvenius, F., Gronman, K., Katajajuuri, J., Soukka, R., Koivupuro, H. & Virtanen, Y. (2014) The role of household food waste in comparing environmental impacts of packaging alternatives. *Packaging Technology & Science*. 27, 277-292.
- Soroudi, A. & Jakubowicz, I. (2013) Recycling of bioplastics, their blends and biocomposites: a review. *European Polymer Journal*. 49, 2839-2858.
- Spaccini, R., Todisco, D., Drosos, M., Nebbioso, A. & Piccolo, A. (2016) Decomposition of bio-degradable plastic polymer in a real on-farm composting process. *Chemical & Biological Technologies in Agriculture*. 3(4), 1-12.
- Spash, C. (2000) Ecosystems contingent valuation and ethics: the case of wetland re-creation. *Ecological Economics*. 34, 195-215.
- Spierling, S., Knupffer, E., Behnsen, H., Mudersbach, M., Krieg, H., Springer, S., Albrecht, S., Herrmann, C. & Endres, H. (2018) Bio-based plastics - a review of environmental, social and economic impact assessments. *Journal of Cleaner Production*. 185, 476-491.
- Steenis, N.D., van Herpen, E., van der Lans, I.A., Ligthart, T.N. & van Trijp, H.C.M. (2017) Consumer response to packaging design: the role of packaging materials and graphics in sustainability perceptions and product evaluations. *Journal of Cleaner Production*. 162, 286-298.

- Steg, L. & De Groot, J. (2012) Environmental Values. In: Clayton, S. *The Oxford Handbook of Environmental and Conservation Psychology*. New York, USA, Oxford University Press, pp. 81-92.
- Steg, L., De Groot, J., Dreijerink, L., Abrahamse, W. & Siero, F. (2011) General antecedents of personal norms, policy acceptability, and intentions: the role of values, worldviews, and environmental concern. *Society & Natural Resources*. 24, 349-367.
- Steg, L., Perlaviciute, G., Van der Werff, E. & Lurvink, J. (2014) The significance of hedonic values for environmentally relevant attitudes, preferences, and actions. *Environment & Behaviour*. 46(2), 163-192.
- Steg, L. & Vlek, C. (2009) Encouraging pro-environmental behaviour: an integrative review and research agenda. *Journal of Environmental Psychology*. 29, 309-317.
- Stern, P.C. (2000) Toward a coherent theory of environmentally significant behaviour. *Journal of Social Issues*. 56(3), 407-424.
- Stern, P., Dietz, T., Abel, T., Guagnano, G.A. & Kalof, L. (1999) A value-belief-norms theory of support for social movements: the case of environmentalism. *Human Ecology Review*. 6, 81-95.
- Stern, P., Dietz, T., Kalof, L. & Guagnano, G. (1995) Values, beliefs, and proenvironmental action: attitude formation toward emergent attitude objects. *Journal of Applied Social Psychology*. 25, 1611-1636.
- Stewart, D.W. & Shamdasani, P.N. (2015) *Focus Groups. Theory and Practice* 3rd Edition. London, UK, Sage Publications Ltd.
- Sudbury-Riley, L. (2014) Unwrapping senior consumers' packaging experiences. *Marketing Intelligence & Planning*. 32(6), 666-686.
- Suer, P., Wik, O. & Erlandsson, M. (2014) Reuse and recycle - considering the soil below constructions. *Science of the Total Environment*. 485/486, 792-797.
- Sue, V.M. & Ritter, L.A. (2007) *Conducting Online Survey*. Los Angeles, USA, Sage Publications.
- Svanes, E., Vold, M., Moller, H., Pettersen, M.K., Larsen, H. & Hanssen, O.J. (2010) Sustainable packaging design: a holistic methodology for packaging design. *Packaging Technology & Science*. 23, 161-175.
- Swait, J. (2001) A non-compensatory choice model incorporating attribute cutoffs. *Transportation Research Part B*. 35, 903-928.
- Tabachnick, B.G. & Fidell, L.S. (2007) *Using Multivariate Statistics* 5th Edition. New York, USA, Allyn and Bacon.
- Tencati, A., Pogutz, S., Moda, B., Brambilla, M. & Cacia, C. (2016) Prevention policies addressing packaging and packaging waste: some emerging trends. *Waste Management*. 56, 35-45.

- Testa, F., Iraldo, F., Vaccari, A. & Ferrari, E. (2015) Why eco-labels can be effective marketing tools: evidence from a study on Italian consumers. *Business Strategy & the Environment*. 24, 252-265.
- Thakur, V.K. & Thakur, M.K. (2014) Processing and characterisation of natural cellulose fibres/thermoset polymer composites. *Carbohydrate Polymers*. 109, 102-117.
- Thiene, M. & Scarpa, R. (2009) Deriving and testing efficient estimates of WTP distributions in destination choice models. *Environmental & Resource Economics*. 44, 379-395.
- Thøgersen, J. & Olander, F. (2003) Spillover of environment-friendly consumer behaviour. *Journal of Environmental Psychology*. 23, 225-236.
- Thompson, J. & Thompson, K. (2009) Can marketing practice keep up with Europe's ageing population?. *European Journal of Marketing*. 43(11), 1281-1288.
- Thompson, R.C., Swan, S.H., Moore, C.J. & vom Saal, F.S. (2009) Our plastic age. *Philosophical Transactions of The Royal Society B*. 364, 1973-1976.
- Tobin, J. (1958) Estimation of relationships for limited dependent variables. *Econometrica*. 26, 26-36.
- Tobler, C., Visschers, V.H.M. & Siegrist, M. (2011) Eating green. Consumers' willingness to adopt ecological food consumption behaviours. *Appetite*. 57(3), 674-682.
- Torgler, B. & Garcia-Valinas, M. (2007) The determinants of individuals' attitudes towards preventing environmental damage. *Ecological Economics*. 63(3), 536-552.
- Train, K. (2009) *Discrete Choice Methods with Simulation*. Cambridge, UK, University Press.
- Train, K. & Weeks, M. (2005) Discrete choice models in preference space and willingness-to-pay space. In: Scarpa, R. & Alberini, A. *Application of simulation methods in environmental and resource economics*. Dordrecht, England, Springer, pp. 1-16.
- Tversky, A. (1972) Elimination by aspects: a theory of choice. *Psychological Review*. 79(4), 281-299.
- Vadori, R., Mohanty, A.K. & Misra, M. (2013) The effect of mould temperature on the performance of injection moulded poly(lactic acid)-based bioplastic. *Macromolecular, Materials & Engineering*. 298, 981-990.
- Valajoozi, M.R. & Zangi, N.O. (2016) A review on visual criteria of pure milk packaging for parents and their children (case study: Tehran, Iran). *British Food Journal*. 118(1), 83-99.
- Valdes, A., Mellinas, A.C., Ramos, M., Garrigos, M.C. & Jimenez, A. (2014) Natural additives and agricultural wastes in biopolymer formulations for food packaging. *Frontiers in Chemistry*. 2(6), 1-10.

- van Birgelen, M., Semeijn, J. & Keicher, M. (2009) Packaging and proenvironmental consumption behaviour. Investigating purchase and disposal decision for beverages. *Environment & Behaviour*. 41(1), 125-146.
- van Dam, Y. & van Trijp, H. (1994) Consumer perceptions of, and preferences for, beverage containers. *Food Quality and Preference*. 5(4), 253-261.
- van der Werff, E. & Steg, L. (2016) The psychology of participation and interest in smart energy systems: comparing the value-belief-norm theory and the value-identity-personal norm model. *Energy Research & Social Science*. 22, 107-114.
- van Riper, C.J. & Kyle, G.T. (2014) Understanding the internal processes of behavioural engagement in a national park: a latent variable path analysis of the value-belief-norm theory. *Journal of Environmental Psychology*, 288-297.
- Vasileva, E. & Ivanova, D. (2014) Towards a sustainable consumer model: the case study of Bulgarian recyclers. *International Journal of Consumer Studies*. 38(5), 475-484.
- Vecchio, R. (2013) Determinants of willingness-to-pay for sustainable wine: evidence from experimental auctions. *Wine Economics & Policy*. 2, 85-92.
- Vecchio, R., Van Loo, E.J. & Annunziata, A. (2016) Consumers' willingness to pay for conventional, organic and functional yoghurt: evidence from experimental auctions. *International Journal of Consumer Studies*. 40, 368-378.
- Vermeir, I. & Verbeke, W. (2008) Sustainable food consumption among young adults in Belgium: Theory of Planned Behaviour and the role of confidence and values. *Ecological Economics*. 64, 542-553.
- Wang, Q., Cai, J., Zhang, L., Xu, M., Cheng, H., Han, C.C., Kuga, S., Xiao, J. & Xiao, R. (2013) A bioplastic with high strength constructed from a cellulose hydrogel by changing the aggregated structure. *Journal of Material Chemistry A*. 1, 6678-6686.
- Wang, Z., Mao, Y. & Gale, F. (2008) Chinese consumer demand for food safety attributes in milk products. *Food Policy*. 33, 27-36.
- Weir, I., Taylor, J. & Welsh, H. (2012) *Plastics recycling business opportunities in Scotland. Identification and analysis of plastic recycling business opportunities in Scotland*, Scotland, UK, Optimal Ltd.
- Wellman, B. (1997) An electronic group is virtually a social network. In: Kiesler, S. *Culture of the Internet*. Mahwah, New Jersey, Lawrence Erlbaum, pp. 179-205.
- Westerman, S.J., Sutherland, E.J., Gardner, P.H., Baig, N., Critchley, C., Hickey, C., Michigan, S., Solway, A. & Zervos, Z. (2013) The design of consumer packaging: effects of manipulations of shape, orientation, and alignment of graphical forms on consumers' assessments. *Food Quality & Preference*. 27(1), 8-17.
- Wikstrom, F., Williams, H., Verghese, K. & Clune, S. (2014) The influence of packaging attributes on consumer behaviour in food packaging life cycle assessment studies - a neglected topic. *Journal of Cleaner Production*. 73, 100-108.

- Williams, H. & Wikstrom, F. (2011) Environmental impact of packaging and food losses in a life cycle perspective: a comparative analysis of five food items. *Journal of Cleaner Production*. 19(1), 43-48.
- Williams, H., Wikstrom, F., Otterbring, T., Lofgren, M. & Gustafsson, A. (2012) Reasons for household food waste with special attention to packaging. *Journal of Cleaner Production*. 24, 141-148.
- WRAP. (2013a) *Consumer attitudes to food waste and food packaging*. Available from: <http://www.wrap.org.uk/sites/files/wrap/Slides%20-%20Consumer%20attitudes%20to%20food%20waste%20and%20food%20packaging.pdf> [Accessed 30th August 2017].
- WRAP. (2013b) *The Courtauld Commitment*. Available from: <http://www.wrapni.org.uk/sites/files/wrap/Courtauld%20Commitment%202%20Final%20Results.pdf> [Accessed 24th January 2019].
- Wright, K.B. (2005) Researching internet-based populations: advantages and disadvantages of online survey research, online questionnaire authoring software packages, and web survey services. *Journal of Computer-Mediated Communication*, 10(3).
- Wu, A. (2014) *Good product, bad package: top sustainable packaging mistakes*. Available from: <https://www.theguardian.com/sustainable-business/2014/jul/18/good-product-bad-package-plastic-recycle-mistakes> [Accessed 3 October 2016].
- Xiong, K., Kong, F., Zhang, N., Lei, N. & Sun, C. (2018) Analysis of the factors influencing willingness to pay and payout level for ecological environment improvement of the Ganjiang River Basin. *Sustainability*. 10(2149), 1-17.
- Yin, S., Chen, M., Chen, Y., Xu, Y., Zou, Z. & Wang, Y. (2016) Consumer trust in organic milk of different brands: the role of Chinese organic label. *British Food Journal*. 118(7), 1769-1782.
- Young, S. (2008) Packaging and the environment: the shoppers' perspective. *Brand Packaging*. 12(1), 24-30.
- Zhao, R., Geng, Y., Lui, Y., Tao, X. & Xue, B. (2018) Consumers' perception, purchase intention, and willingness to pay for carbon-labelled products: A case study of Chengdu in China. *Journal of Cleaner Production*. 171, 1664-1671.
- Ziaei-Bideh, A. & Namakshenas-Jahromi, M. (2014) Explaining effective factors on consumers willingness to pay more for buying green products based on the Value-Belief-Norm theory. *The Open Access Journal of Resistive Economics*. 2(2), 19-29.
- Zwerina, K. (1997) *Discrete Choice Experiments in Marketing. Use of Priors in Efficient Choice Designs and Their Application to Individual Preference Management*. Heidelberg, Germany, Springer.

Appendices

Appendix 1 Ethical clearance for in-depth interview with experts

School of Agriculture, Policy and Development



Form 2. MSc PhD Staff Ethical Clearance Submission Form

PLEASE allow a minimum of 3 weeks for this process.

You must not begin your research until you have obtained consent as evidenced by this form returned from the APD student Office signed and dated. Ethical Clearance cannot be granted retrospectively.

This form can only be used if the application :

- Does not involve participants who are patients or clients of the health or social services
- Does not involve participants whose capacity to give free and informed consent may be impaired within the meaning of the Mental Capacity Act 2005
- Does not involve patients who are 'vulnerable'
- Does not involve any element of risk to the researchers or participants
- Does not involve any participants who have a special relationship to the researchers/investigators

If any of the above apply, please refer to the APD Ethics Chair to decide whether an application can be made through the APD review process or whether the application needs to be referred to the full University Committee.

It is the applicant's responsibility to check for any particular requirements of a funder regarding ethical review. Some funders may require that the application is reviewed by full University Committee and not the devolved School committee.

Full details of the University Research Ethics procedures are available at <http://www.reading.ac.uk/internal/res/ResearchEthics/reas-REethicshomepage.aspx> and you are encouraged to access these pages for a fuller understanding. Some helpful advice is available on this link <http://www.reading.ac.uk/internal/res/ResearchEthics/reas-REwhatdoIneedtodo.aspx> and the FAQs are particularly relevant.

ALL QUESTIONS MUST BE COMPLETED.

APD Ethical Clearance Application Reference Number : M00297

1. APPLICANT DETAILS:

Main applicant name:	Nur Hafizah Muhammad
Name of academic supervisor/project investigator:	Giuseppe Nocella & Nick Beard
Email Address (decision will be emailed here):	n.h.muhammad@pgr.reading.ac.uk
MSc Student	<input type="checkbox"/>
PhD Student	<input checked="" type="checkbox"/>
Staff Member	<input type="checkbox"/>
Other (please specify)	Click here to enter text.

2. PROJECT DETAILS:

Title of project: Pro-environmental behaviours impact on consumer choices of sustainable food packaging
Please provide a lay summary of the project, including what is being investigated and why: This study aims to measure the relationship between environmental awareness with pro-environmental purchasing behaviour of

Appendix 2 *In-depth interview research protocol*

IN-DEPTH INTERVIEW PROTOCOL

Introduction by interviewer (5 minutes):

Self-introduce and introduce research as shown in questions sheet
Distribute or read written informed consent

Opening question (3 minutes):

Ask participant to briefly talk about job details and responsibility in the organization.

Introductory question (12 minutes):

What are your overall thoughts about the sustainable packaging so far?

Key topic areas: As written in questions sheet (25 minutes):

Pros and cons of sustainable packaging
Feelings when be informed the packaging possibly cause damage
Evaluation of the must-have attributes of the business packaging

Ending questions (10 minutes):

With this sustainable packaging..... what things out of all the things we have talked about today

- Need to remain the same and prioritise?

Closing (5 minutes):

Summarise
Is there anything else you would like to add about the way in which the mentioned packaging involved in reduction of waste in community?

Thanks participant

IN-DEPTH INTERVIEW QUESTIONS

1. In general, what are **the trend and issues** of current food packaging in the market?

Memo point:

- *Trends and issues in food packaging 2016:*
 - *Material substitution*
 - *Convenience (i.e. Light weight, excessive packaging)*
 - *Label transparency and trust*
 - *Sustainability logo like Carbon footprint, recycling, etc*
 - *Sustainability efficiency*
 - *Healthy living (i.e. natural ingredient formulation material)*
 - *Others*

2. What is the current **packaging policy that your company** used for food-contact packages (primary packaging)?

Memo point:

- *Type of packaging materials for different group of food product*
- *Choose the right packaging material for right product*
- *Label specifically the materials used*
- *Maintain two-way communication with consumer information label*
- *Partner with local packaging material supplier*
- *Others- describe other ways the company monitors and manages packaging policy*

3. Does the company have an **environmental policy for food-contact packaging** through the sustainable development policies (CSR)? How far your company apply this policy?

Memo point:

- *About use of **plastic in packaging** because paper box or metal generally known to be recyclable*
- *Develop a recycling program or packaging*
- *Formed an environmental or waste audit regarding post-used packaging*
- *Practice energy reduction when possible*
- *Supplier for packaging; local or import*
- *Assessment and review opportunities for improvement and changes to packaging in accordance with goal of sustainability*
- *Other- what other plans do you have in place for promoting the sustainable packaging efficiency*

4. Do you have any plan for **new potential materials** to replace the **current packaging of the company**?

Memo point:

- *On specific type of food product:*
 - *Fresh produce (**perishable**): Meat? Poultry? Vegetables? Fruits? Bakery?*
 - *Dried (**Non-perishable**): Nuts? Dried fruits?*
 - ***Why?***
i.e. because this type of product packaging often found to pack with conventional plastic packages and Styrofoam plates (i.e. raw meat)
- *Purchase "green" materials (recyclable, reusable, non-toxic, degradable or made from 100% post-consumer recycled material)*
- *Label the materials used*
- *Partner with local sustainable supplier*

- *Utilise supplier who share sustainability commitment*
- *Partner with recycler who share sustainability commitment*
- *Others- describe other ways the company monitors and manages packaging policy*
- *Follow the trend:*
 - *New material such as biopolymer (plastic from renewable sources like plant commodities, microbial by-product or biomass)*
 - *Encourage recyclable, reusable and degradable materials*
 - *Flexible characteristics: lightweight, minimize cost, transport or delivery friendly*
 - *Others- describe more on the advantages of the materials will used by that specific food product*

5. If the company has plan for sustainable development of packaging, would you please elaborate on how **that sustainable package** will be designed with an extension of traditional design considerations in mind?

Memo point:

- *Outline the **main design strategy or concept** that might be employed to achieve the sustainable vision:*
 - *Design for cradle-to-cradle system*
 - *Resource recovery packaging*
 - *Improve foodstuff characteristics as well packaging like active packaging or intelligent packaging*
 - *Others- describe what the company does to minimise the environmental impact and cost associated with packaging*

6. There are **nine (9) design objectives** of packaging to define quality for both foodstuff and environment have found in literature. How is your **company trying** to do to meet these packaging quality objectives (for that above-mentioned sustainable packaging)?

- **Technical performance:** does package protect the food?
 - *Balance need with over-engineering*
 - *Consider whole packaging system: transportation, processing or machinery limitation*
- **Cost:** is the design cost effective?
 - *Align cost for target market? How much it will cost as **end-product**?*
 - *Use materials and energy efficiently over its lifecycle*
 - *Does consumer have **to pay more** for that packaging?*
- **Appearance:** does the design communicate effectively as before?
 - *Special logo emphasizes the sustainable goals*
 - *Communicate well as normal packaging*
 - *Communicate clearly as it will save the environment*
 - *Sustainability design properties like re-sealability, individual pack, eco-shape*
- **Regulatory compliance:** does the design obey or exceed the regulations?
 - *Meet the applicable regulations for food contact packaging*
 - *Comply with any labelling requirement: nutritional facts etc.*
- **Optimize resources:** does the design optimize use of materials and energy?
 - *Practice on source reduction*
 - *Use recycled content if possible*
 - *Applicable to function as packaging: suit for transportation*

- **Responsible sourcing:** has the material been produced and delivered responsibly?
 - *Design with renewable materials*
 - *Design with environmental best practice*
- **Material health:** are the materials safe and healthy for consumer and the environment?
 - *Know the potential health and environmental impact*
 - *Know the chemistry of the material in the package if contact with foodstuff*
- **Resources recovery:** where will the packaging go after use?
 - *Design for reuse, recycling, decomposing or so on*
- **Sustainability benefits/ aspects:** does the design highlights the environmental messages?
 - *Without disturbance on the product content*
 - *Give an extending shelf-life?*
 - *How it will dispose after usage? General waste or separate bins*
 - *How the package will decompose? It will degrade naturally, special treatment or active compose soil*
 - *Free or less impact on the environment (i.e. low greenhouse gases emission, low global warming potential (GWP))*

7. **Any other attributes** or characteristics that differ your company sustainable food packaging with others?

8. In your view, how do you see **consumer acceptance** of that designed sustainable packaging plan?

Memo point:

- *Consumer reactions in terms of **cost** and the **sustainable message** the packaging portrayed?*
- *Does consumer really care the type of packaging that they use?*
- *Does consumer recognise if your company change your packaging to the sustainable packaging as planned above?*

Appendix 3 Interview respondent consent form

PARTICIPANT INFORMATION SHEET

Reference number:

Project name: Pro-environmental behaviours impact on consumer choices of sustainable food packaging. I am a PhD student at the University of Reading. As part of my thesis, I am conducting this research to the attainment of qualification at this university.

This research project aims to find out purchasing behaviour of sustainable food packaging with respect of environmental awareness among consumer. We are interested in exploring willingness to pay for that sustainable packaging as its will be one of the prevention steps to avoid more waste problems.

To undertake this research, we are currently contacting businesses and experts. We would like to invite you to participate in an in-depth interview which will take approximately 1 hour of your time. You have been selected as participant for this research and we are interested in your view regarding sustainable packaging attributes and the preferences of general public on criterion of packaging for a food product. You are encouraged to freely express your opinions and please be assured that your views are valued and that there are no right or wrong answers to the questions asked.

We will not collect any names or personal details as part of the interview. Your identity will not be revealed to anyone other than the researchers conducting this survey. *[Alternatively use keyed anonymity where contact details are held separately which can link the participants input to their contribution provided the researcher has access to both sets of data, for example: I will store your name and email address so that I can contact you in 6 months' time to ask follow up questions. Your name and email address will be linked to your original responses by means of a keyed spreadsheet held separately. This spreadsheet and contact details will be password protected and the password known only to me and my supervisors and will not be shared with any third parties. The spreadsheet will be kept on my password protected desktop and will be destroyed at the end of my degree in September 2018. Your name and email address will not be published as part of my research. As all data is presented in aggregate format it will not be possible to identify any individuals from their responses].*

Participation is entirely voluntary, and you are free to withdraw from the interview at any time you feel uncomfortable or unwilling to participate, and you do not have to specify a reason. The discussion will be audio or video recorded if you agree, and the anonymised transcripts of the audio/video recordings will be used by the researchers working on the project. Once transcribed the original recording will be deleted. Your anonymity will not be compromised as only the reference number above will be used to identify the transcript. If at any stage you wish to receive further information about this research project, please to not hesitate to contact Nur Hafizah Muhammad (me) before July 2018. The findings will be written up into my thesis/included in a report to sponsor/ published in academic journals. This will not affect your anonymity.

All data I collect will be stored securely electronically on a password-protected computer or in hard copy version in a locked cupboard following the University of Reading guidelines. The data will be destroyed at the end of the research project no later than 31/12/18.

By participating in this interview, you are acknowledging that you understand the terms and conditions of participation in this study and that you consent to these terms.

This research project has been reviewed according to the procedures specified by the University Research Ethics Committee and has been given a favourable ethical opinion for conduct.

Thank you very much for taking time to take part in this research.

Appendix 4 Example of interview transcription

Interview 1

Interviewer: Nur

Interviewee: Programme Area Manager from WRAP

Interview Setting: Interview conducted via phone in Agriculture Building (UoR). The interview was conducted at 10:00 AM on Tuesday, 13th September 2016

(Start the interview)

Interviewer: The trend and issues in current food packaging in market today's?

Interviewee: With my role in WRAP and what we are doing in WRAP. There is a lot of information you can find in our website and you could spend some time to take look on it like the reports or anything. So, I'm being work on packaging in WRAP since 2005. I had been worked with brands and retailers on regards of the lightweight and reduce the packaging they put on the shelves within the UK. And we also help them to increase the amount of recycle content that they used within their packaging. Also, from the recycling side, we help to develop recycling criticise and new market for recycle materials that come out from previously packaging. But, it may be not able to be back to packaging again. We are not specifically working on pack that light weighing anymore, so we got a lot of information on our websites. If you look on Courtald commitment on our website there are all the work that we being doing with brands and retailers. So, there are lots of reports, case studies on light weighting. Currently, on what we are doing now is where packaging helps to expend food shelf life or help to prevent food waste. So, we kind of move on from getting the packaging fits for purpose, it is like if the packaging is badly design or so light, it will affect the shelf life of the content and become wastage. The massive pack is much worse where used of boxes to deliver what it supposed to deliver and then, it might be to improve shelf life. So, it might means to come forward on the packs that currently are not collected to recycle and we currently keep eyes on that. There is some packaging format that is not economic and does not make sense to collect them separately. For example like flexible pouches. There is some shift to that format (pouches) in food products. But, there are still vast majority of food cans, tetrapak, plastic bottles, plastics, trays and jars used for food. The other things we work on, we provide technical guidance to the scheme called The On-pack Recycling Label. That is the membership based scheme where the supermarkets or brands can sign up to be a member and then, on their packaging, they allow using our label to say whether the packaging is either widely recycle or not recycle. And also there is third label that you have to check locally because the information of recycle that fix on the label is based on what is collected at the curb side by our local authorities. So, enough local authorities to offer the collection, it is widely recycle; only few local authorities collected, it is not recyclable; and some local authorities offer something but not others, it is check locally. So, that is the labelling can come in for this scheme. The scheme is about 4 to 5 years, so we aims about 70, 000 to 80, 000 pieces of packaging and we got over 5000 members of the scheme. We don't own the scheme, we licenced the label and provide the technical guidance on how you able to use the label or not. From there, we work with local authorities by looking at their collection schemes and we launching today to more consistent ways of collecting within England. So, based on numbers of materials and tonnes of materials them collecting, so that may influence the material choices by retailers and brands on what packaging they used. The main purpose is to protect the product and get the cheaper packaging and also the packaging that can be seen by their consumers as the pack that can be recyclable. This is because based on the research we done, people make a choice around the product packaging due to the attractiveness, and some are not because it can be recycling or whatever. They don't consciously think that I buy that item because I know that item can be...

Appendix 5 Ethical clearance for focus group discussion

- I am satisfied that this application meets the minimum standards for APD Ethical Clearance to be granted

Supervisor/Project Investigator, please forward this form as a WORD document and any separate supporting documents to sapdethics@reading.ac.uk. The form will be logged by the student office and allocated to an APD ethics committee reviewer. The APD ethics reviewer will review the application and complete section 6.

6. APD ethics committee review. Section to be completed by APD Ethics Committee member.

Decision

- | | |
|--|---|
| Clearance refused | <input type="checkbox"/> Resubmission required |
| Clearance granted as presented | <input checked="" type="checkbox"/> |
| Clearance granted subject to revisions suggested | <input type="checkbox"/> No need to resubmit once amended |
| Referred to APD Research Ethics Chair | <input type="checkbox"/> May require further information |

Ethics Committee Member please enter comments, reasons for rejection, summary of revisions required before proceeding (if applicable):

[Click here to enter text.](#)

Committee Member Name: Ariane Kehlbacher

Date Reviewed : 03/05/2017

Form 1: APD MScPhDStaff Ethical Clearance Application Version 1.0 Last updated 30/11/15

Help Us!



Focus Group on "Sustainable Packaging"

Who can join?

1. UK citizen
2. 19 years above
3. Responsible for grocery shopping
4. available for about 1 and half hours

*Free
Refreshments*

**YOUR VOICE MATTERS
PLEASE GET IN TOUCH FOR DETAILS**

£30

**PLEASE CONTACT US AT
AGRICULTURE BUILDING UOR:**

Nur Hafizah Muhammad

Tel. no:07492732128(sms or call)

0118 378 5239(9am-6pm)

n.h.muhammad@pgr.reading.ac.uk

FOCUS GROUP DISCUSSION PROTOCOL

- a. Welcome speech
- b. Overview of the topic
- c. Basic guidelines
- d. *Part 1:* Ice-break and sustainability questions
- e. *Part 2:* Consumer's view and awareness of consequences of current packaging
- f. *Part 3:* Introduction of sustainable packaging and consumer's sense of responsibility
- g. *Part 4: Introductory questions to product packaging*
- h. *Part 5:* Association to innovation in sustainable packaging for fresh milk
 - (1) Packaging outline
 - (2) Packaging functionality
 - I. Quality design
 - II. Convenience design
 - (3) Packaging labelling
- i. *Part 6:* Sustainable packaging and policy
- j. *Part 7:* WTP for sustainable food packaging innovation
- k. *Part 8:* Ending questions

a. Welcome (3 to 5 minutes)

Good morning and welcome. Thanks for taking the time to join our discussion on food packaging. My name is Nur Hafizah and I am now in my second year of PhD in Agriculture and Food Economics. Assisting me is _____. I will hand out the consent form and please fill in the demographic questions attached as well. If you have any queries or questions regarding the form, please feel free to ask.

(Make sure participant signs the consent form and offer a copy of it to each person)

b. Overview of the topic

Generally, today's topic aims to explore the innovation of sustainable food packaging from consumer's point of views. The purpose of this discussion is to find out and evaluate that packaging innovation as its will be one of the prevention steps to save the environment. I will explain the concept of sustainable packaging, shortly.

We would like you to think about an ideal sustainable food packaging to suit your needs. You may give an explanation about the packaging characteristics that either do or do not work well to you for specific reasons and please cite some examples if you would like.

c. Basic guidelines

There are no right or wrong answers. We expect that you will have differing points of view. Please feel free to share your point of view even if it differs from what others have said.

We are recording the session because we don't want to miss any of your comments. No names will be included in any reports. Your comments are confidential. Don't feel like you have to respond to me all the time. If you want to follow up on something that someone has said, you want to agree or disagree or give an example, feel free to do that. Feel free to have a conversation with one another about the questions. I am here to ask questions, listen and make sure everyone has a chance to share their opinion. We're interested in hearing from each of you. So, if you're talking a lot, I may ask you to give others a chance. And if you're not saying much I may call on you. We just want to make sure all of you have a chance to share your ideas.

The session will go on no longer than 60 minutes with no breaks. Moreover, if you have a cell phone please put in the quiet mode, and if you need to answer step out to do so. Feel free to get up for restroom if you would like.

d. Part 1: Ice-break and sustainability questions (5 minutes)

Let's begin. Let's find out more about each other by going around the table one at a time. **Please introduce your name and what should we call you.**

Memo to facilitators: Information about age, gender, occupation and income should be collected from the consent form.

As shown in your invitation to this focus group, we will be discussing on sustainability in food packaging. Basically, sustainability is an abstract concept and people may attach different meanings to it depends on your perception (Grunert et al, 2014). So, it is better to start the discussion with your general opinions on sustainability.

What is sustainability to you?

Memo to facilitators:

How is sustainability important to yourself, family/friends and environment?

Would you give some examples of sustainability issues that you are concern most?

What do you think of human action today affecting the future generation and the environment (including plants and animal)?

Do you think people are abusing the environment?

Is human has right to modify or use the environment more than other species?

e. Part 2: Consumer's view and awareness of consequences on current packaging (10 minutes)

When you do shopping for any grocery product, do you consider the packaging:

- **SHAPE** when choosing a product to purchase? If so, please explain how and why.
- **FUNCTION** when choosing a product to purchase? If so, please explain how and why.
- **MATERIAL** when choosing a product to purchase? If so, please explain how and why.

Memo to facilitators:

The main underlying reasons for their behaviour when they choose any product.

It could be because of the product or how to dispose of the packaging?

It could be because of how to transport it to home or storage matters?

Notes to facilitators:

- 1. Shape defines as the physical appearance of the package such as round, square etc.*
- 2. Function defines as the ability of the package to protect, communicate and provide convenience to the consumer.*
- 3. The material defines as the substance used to make the package such as paper, glass etc.*

Now we proceed to the food and drink packages on the market. **How do you feel about the current food packaging?**

Memo to facilitators:

Is it generating environmental problem?

Is it producing more packaging waste?

Is it overly-designed with unnecessary functions without a clear purpose?

Is it using material that will harm the environment or people?

Generally, from all types of grocery packaging on the market:

- Which packaging do you think has the **GREATEST NEGATIVE** environmental impact? Please describe your answer.
- Which packaging do you think has the **LEAST NEGATIVE** environmental impact? Please describe your answer.

Memo to facilitators:

An example of expected answer, "Paper style of the package because it is able to recycle and naturally decompose. Moreover, it is easy to sort out into waste bin".

Group members may also give an example of the product package that they think would harm or less harm the environment.

f. Part 3: Introduction of sustainable packaging and consumer's sense of responsibility (10 minutes)

Introduction:

Packaging becomes a major contribution to solid waste around the world. Food packaging waste piles up the landfills, at the streets and clog up out the waterways; eventually creating a serious environmental issue. In the UK, 34% of 1.3 million tonnes packaging used are not able to dispose and end up in landfills (WRAP, 2009). A survey shows that consumers were concerned with the current packaging problems and it might affect the well-being of their family and environment too.

<Show Card 1 in card document>

Memo to facilitators: Here is the result of the survey conducted by WRAP in 2013. In general, it summarised some of the concerns expressed by consumers regarding the current food packaging problem. Please take your time to read it and I will proceed with the questions after that.

As a consumer, how do you feel on the responsibility of environmental problem creating by packaging?

Memo to facilitators:

Is it your sole responsibility?

Is it government or food company's responsibilities, but not yours?

What is your action to decrease the amount of the problem?

If you do not litter properly, what do you think will happen to your garbage on the environment and people health surrounding you?

How important is the package in your choice of a food product from an environmental perspective?

Memo to facilitators:

If it is very important, please provide reasons.

If it is least important, please provide reasons for the answer.

Example: Very important because it added to the quality of life or to live with the clearer environment.

Do you change your product choice because of the packaging?

Recently, stakeholders have introduced sustainability concept on food packaging. The objective of sustainable packaging is producing a package that safe for the environment, gives convenient for the consumer and economically viable for consumers and stakeholders as well. Generally, it is the package that satisfies the needs of today's consumer without risk the needs of next generation.

Please tell us what do you understand of this sustainable concept packaging?

Memo to facilitators:

Do you have any idea what is the packaging is all about?

Have you heard about sustainable packaging before?

If they do, how far the effectiveness of the packaging concept?

What do you think the benefits it will give to you and environment?

Personally, in your opinion, how do you feel buying a product wrapped with sustainable packaging?

Memo to facilitators:

Will it decrease the environmental problem?

Will it make you feel better as a consumer?

Do you still buy it even you are not understood the purpose of the packaging?

What do you think will happen to the environment if you do not buy sustainable packaging product?

What do you think will happen to your family and friends if you do not buy sustainable packaging product?

g. Part 4: Introductory questions to product packaging (10 minutes)

Introduction:

Food companies are continuing to develop (or upgrade) new sustainable food packaging for day-to-day food and drink product. With support from the NGO and government, the companies re-design their food and drink packages leading on save for environment and consumer; besides 'fits for its original purpose'.

Here are some examples of packaging for milk available in the market. Please take 5 minutes to review it. Please rank those packages from 1 to 9. In your views, which one of these packagings is the most sustainable to you? Why?

<Show Card 2 in card document >

Memo to facilitators:

Please justify your reasons

How far the effectiveness of the chosen packaging?

Is there any food packaging that you have found to be sustainable to you in the market which is not on the card?

As seen in the grocery store, there is a huge selection of food and drink products that you can choose. However, for this project purpose, we are focusing on the most basic and highly purchased household product in 2016, **MILK**.

How often do you buy milk in a week? It is either for you or for your household.

Memo to facilitators:

Does milk is a day-to-day product to you?

How often you consume milk?

By assuming the product is identical across the entire packaging for one liter of MILK, what is the first thing you observe on the milk packaging when you want to buy it?

Memo to facilitators:

Go around the table

Please get the feature and the reason underlying the choice

From your perspective, is packaging for milk environmental friendly?

Memo to facilitators:

Go around the table

If yes, why?

If no, why?

h. Part 5: Association to innovation in sustainable packaging (20 minutes)

From the previous literature and discussion with experts in the food industry, there are **three** technical parts of innovation in the sustainable packaging that food companies focus on currently. There are **packaging outline**, **functionality** and **label information**. All the innovations aim to meet the consumer requirements as well as remain safe for the environment.

1) Innovation one: Packaging outline

We will discuss the innovations one-by-one and it will begin with **packaging outline** of milk product. Please imagine this is packaging for **one liter of milk** and it is remaining identical for all packaging.

The type of **MATERIAL** is one aspect in the packaging outline. Packaging material that harmless to consumer and environment is the best option to use for a package. The best environmental option for a package is the material that energy can be recovered

from the usage. Therefore, there is a lot of type of material selection that be used by the manufacturer.

<Show Card 3 in card document>

Recyclable, Degradable, Biodegradable, Compostable, Reusable

Please have 3 minutes to review the card. Rank the options from 1 to 5. Which of these environmental options are most and less preferable as sustainable packaging material applicable for milk product?

Memo to facilitators:

Would you please tell me the reason for your choices?

You are also can list down the type of packaging material that familiar to you if it is not on the list or I mistakenly might have left out.

Besides material, packaging **SHAPE** also indirectly influence the choice due to its weight, storage spaces, travelling purpose or others. Thus, sustainable innovation has developed the shape of packaging to ease the consumer usage. **Here are the examples of the packaging shape innovations over the years.**

<Show Card 4 in card document>

Box/carton, can, jar/bottle, pouch

From the card, please pick the favourite and least favourite option for milk packaging by rank it from 1 to 4:

Memo to facilitators:

Would you please tell me the reason for your choices?

You are also can list down the packaging style that familiar to you if it is not on the list or I mistakenly might have left out.

2) Innovation two: Packaging functionality

We will now proceed to the second innovation of sustainable packaging. It focuses more on the **functionality** as a packaging. This innovative design of sustainable package aims to deliver convenience to the consumer, primarily. It is also presented an environmental-friendly way to reduce the amount of packaging used for the product.

Here, I will explain to you one-by-one and ask your views on those innovative designs. **Quality** and **convenience** are two functionality designs highlighted in research paper and experts.

Again, please imagine it is for packaging of **one litter milk** and it is remaining identical for all packaging.

I. Quality design

Packaging helps to maintain the quality of the product inside the package. Another aim of sustainable packaging concept is providing indifferent quality or improve the **QUALITY** of food.

<Show Card 5 in card document>

What are your expectations on the food quality with the innovation of sustainable packaging in terms of shelf-life and also other expectations of milk quality? Please write your answers in the blank space provide on Card 5.

Memo to facilitators:

What do you want your product quality would be if this packaging is used in terms of?

Shelf-life: How many days more from standard shelf-life? Why?

Freshness or attractiveness: How your fresh milk quality should look like in the packaging?

II. Convenience design

Another aspect of the design, sustainable innovation also intends to deliver CONVENIENCE to the consumer. The innovation helps the consumer in handling and protecting the product as well.

Here are some packaging functions to promote sustainability. Please take 3 minutes to read it. Again, what do you think of these functions on one litter of MILK product? Rank the functions from 1: favourite until 6: least favourite.

<Show Card 6 in card document>

Re-closable / re-sealable, Easy to dispose of, Grip ability, Second use, integrated use, Openability

Memo to facilitators:

Please give your opinion and how important these functions to you?

Would you please describe more in-depth of each of this function whether it is important to you or otherwise?

3) Innovation three: Packaging labelling

The last innovation that will discuss is the ability to communicate well to consumer. Besides the legally compulsory information about the product, the message a packaging communicates to the consumer can be from instructions from how to handle packaging until any information of their effort on innovation in the. Such communication that can facilitate efficient usage and provide confident in consumers on their action to support world sustainability. Therefore, LABELLING is an essential tool for the food industry as it educates consumers and familiarises them with the sustainability product the industry produced.

Sustainable cues focussing the credence attribute of packaging are some hint to tell consumer nonverbally on how food manufacturers support the sustainable campaign. Once more, please imagine it is for packaging of **one litter milk product** and it is remaining identical for all packaging.

Here is the example of a product label:

<Show Card 7 in card document>

From the card, you able to see several symbols or phrases related to sustainable of the packaging. There are:

1. Food company's own personalised sustainable 'information'
2. Official accreditation of the packaging material such as FSC or PlantBottle

3. Certified scheme on information of packaging material to help consumer handle the packaging waste like OPRL scheme
4. Certified program to provide information how consumers contribute to the safer environment
5. Association with organisations which aim to protect environment like WWF, Soil Associations
6. Environment-related colour

Which of these symbols or phrases on your packaging are familiar to you?

Memo to facilitators: Please go around the table. If possible, ask where they find it? On which food product?

In which of these labels are important or necessary to you to appear on your product label? So, you will be able to show responsibility towards sustainability.

Memo to facilitators:

Please rank it and tell us the reasons of your choice

You are also can list down any information that you want to see on the packaging if it is not on the list or I probably overlook.

Which information is necessary to you as a consumer? Besides the legally required information like expiry date, customer service, ingredients list, weight or etc.

Last question on this card, which sustainable label should be legally compulsory on the packaging?

Memo to facilitators: Please go around the table. If possible, ask reasons?

i. Part 6: Sustainable packaging and policy

We are going to move our focus slightly on the policy related to packaging and sustainability. EU derivative on packaging reinforced food producers to design reusable and recoverable packaging they put on the market. Moreover, UK legislation also encouraged food producers to upgrade the packaging that safe for the environment. **As a consumer, should any legislation and regulation on food packaging be available publicly or confidentially to the food producer only?**

Memo to facilitators:

Please explain your answer either publicly or confidentially.

If publicly, how you want it to be announced to all groups of consumers?

If confidentially, to what extend the food producer has right to conceal the packaging information?

It is legally required to indicate packaging information visible and legible for facilitating next users of the package such as waste management company. It is written usually in the technical term (ex: Plastic 7-triangle codes). **So, should the word/term/symbol regarding the packaging printed to be understandable for consumer as well?**

Memo to facilitators:

Do you think consumer need to know all information printed on the package?

If yes, why?

If no, what is an essential information on packaging to you?

Do you think it should be legally implemented to grocery packages?

In sustainable packaging, UK 'Environmental Claim' regulation (Updated December 2016) stated that the claim should be; not misleading, clear and accurate; objective and transparent. **In your views, do you have any issues in trusting the claims about the packaging?**

Memo to facilitators:

Explain the issues, briefly.

Does it affect your choices in buying the product?

Do you look out the claims somewhere else like the internet, to confirm it?

If you find any fraud statement made by food producers, what is your action?

Before we move to another part of the discussion, does anyone has other concern on any policy related to packaging and sustainable that you would like to raise?

j. Part 7: WTP for sustainable food packaging innovation (10 minutes)

We are now going to discuss on the willingness to pay this new sustainable packaging for **ONE LITTER OF MILK** product.

<Show Card 8 in card document>

Imagine that 1L milk is on sale at the price of £ 1.00 in your favourite shop and is marketed using innovated sustainable packaging that satisfy your preferences. Which of the amounts listed in the table describes your maximum willingness to pay on innovative sustainable packaging to improve your satisfaction towards sustainability?

Please tick (✓) on the payment card the minimum and maximum amount you will pay for 1 L of milk product.

Memo to facilitators:

Market average price for one litter of fresh milk is £1.00.

Part 8: Ending question (5 minutes)

Lastly, to end our discussion, does anyone have any other points and suggestion regarding on the topics we discussed? So, it can help me with my study in the future.

Memo to facilitators:

Please go around the table.

If possible, ask reasons of the choice?

Collect the cards from the participant

Give incentive form and ask the participant to enjoy the refreshment more

That remarks the end of our discussion. Your feedbacks and times being here are very much appreciated.

END

Appendix 8 Focus group cards

School of Agriculture, Policy and Development



Reference number:

Name: _____

Card 1

Survey of Consumer Attitudes to Food Packaging by WRAP (2013)

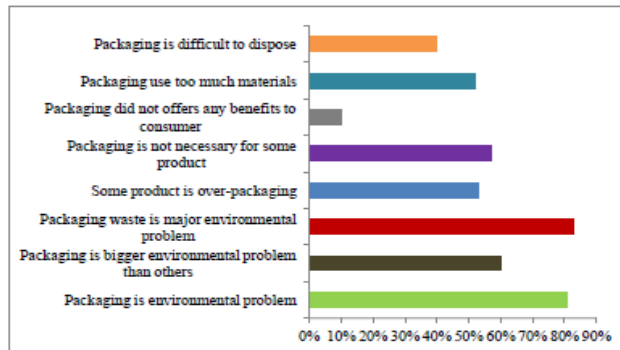

Card 2

Please read at these packaging carefully and rank them from 1 to 9, assign into the most sustainable and the least sustainable to you in the box given



Glass bottle



On-the-go carton with straw



Transparent plastic container



White plastic bottle



Carton with cap



Carton without cap



White plastic pouch



Transparent plastic bottle



On-the-go pouch

Card 3

Please read carefully of these 5 environmental options of packaging material. Then, rank them from the most and less preferable to you for 1 L of milk.

<input type="text"/> Recyclable	<p>Material design to collect and reprocess to produce another item. It can be litter in any available recycle bin.</p> <p>Types of material: Paper; Metal; Glass; Bioplastic (plastic made from agricultural waste like wood pulp, corn, soy or sugar cane); Recyclable plastic.</p>
<input type="text"/> Degradable	<p>Material design to breakdown into small particles after chemical reaction with oxygen, light or heat after disposal. It is made from wood pulp and plastic. It is also likely to survive long enough for deteriorate.</p> <p>Types of material: Regular plastic (weakened structure or chemical additive); paper</p>
<input type="text"/> Compostable	<p>Material design to breakdown into carbon dioxide, water and compost. It produces no trace and no toxin, but producing a nutrient-rich soil. It is made from wood pulp and plant-plastic. For plant-plastic, it can be decomposed at home or industrial facility; but takes 90 – 180 days to breakdown.</p> <p>Types of material: Paper; Bioplastic</p>
<input type="text"/> Bio-degradable	<p>Material design to breakdown into carbon dioxide, water and methane gas from action of naturally-occurred microorganism likes bacteria. It is made from fuel-based plastic or plant-plastic where can only be decomposed in special facility.</p> <p>Types of material: Bioplastic (plastic from plant); paper</p>
<input type="text"/> Reusable	<p>Material design for repeated usage more than one times as the same packaging commercially. It has attributes such as durability, ease of cleaning or provide inexpensive return when empty</p> <p>Types of material: Glass</p>

Card 4

Packaging Style

Please rank from 1 to 4 of your favourite and least favourite shape of 1 L milk packaging.

One litre of Milk

<input type="text"/> Carton/Box	<input type="text"/> Bottle/Jar
<input type="text"/> Can	<input type="text"/> Pouch

Card 5

What are your expectations on the MILK QUALITY with the innovation of sustainable packaging?

Shelf-life

How many days from standard shelf-life? Why?

.....
.....
.....
.....

Other expectations of milk quality for innovation of sustainable packaging?

.....
.....
.....

Card 6

Packaging function is the ability of the package to protect, communicate and bring convenience to consumer. Here are 6 packaging functions, please read carefully and rank them from 1 to 6, as 1 is your favourite to 6 is your least favourite function for innovation of milk packaging?

- Easy to dispose** • Package that is easy to sort into waste bin after use. It includes easy to rinse, fold and avoid confusion on how to dispose
- Gripability** • Ability to grip the package determined by size, shape, handle, material stiffness and packaging surface
- Second use** • Package that developed with second use in mind after use the product inside
- Integrated use** • Package that able to use as serving (tray), preparing or consuming the product directly in the package to optimise the utilisation
- Openability** • Ability to open with or without tools for all groups of consumer
- Re-closable/ Re-sealable** • Features that keeping the package tight and maintaining product quality after it has been opened.

Card 7

This is an example of a label on a food packaging. Please look at it carefully, which of these labels/phrases on any food packaging are FAMILIAR to you?

(1) Personalised sustainable information

(2) Official accreditation of material

(3) Certified scheme to dispose packaging

(4) Certified scheme to inform the involvement made by buying this product

(5) Association with environmental organisation

(6) Environment-related colour

Card 8

Payment card

Imagine that 1L milk is on sale at the price of £ 1.00 in your favourite shop and is marketed using innovated sustainable packaging that satisfy your preferences. Which of the amounts listed in the table describes your maximum willingness to pay on innovative sustainable packaging to improve your satisfaction towards sustainability?

Please tick (✓) on the payment card the minimum and maximum amount you will pay for the milk product.

Amount (£)	Please tick minimum & maximum
0.00	
0.01	
0.02	
0.03	
0.04	
0.05	
0.06	
0.07	
0.08	
0.09	
0.10	
0.11	
0.12	
0.13	
0.14	
0.15	
0.16	
0.17	
0.18	
0.19	
0.20	
0.21	
0.22	
0.23	
0.24	
0.25	
0.26	
0.27	
0.28	
0.29	
0.30	
More than 0.30 (Please specify)	

Appendix 9 Focus group respondent consent form

School of Agriculture, Policy and Development



PARTICIPANT INFORMATION SHEET

Reference number:

Study name: Pro-environmental behaviours impact on consumer choices of sustainable food packaging.

I am a PhD student at the University of Reading. As part of my thesis, I am conducting this research to the attainment of qualification at this university.

This study aims to explore the consumers' willingness to pay sustainable food packaging with respect to their environmental consciousness. To undertake this research, we are currently contacting consumer from all age groups. We would like to invite you to participate in this group discussion which will take approximately no more 60 minutes of your time. You have been selected as participant for this research and we are interested in your views and preferences on sustainable packaging concept from consumer perception. You are encouraged to freely express your opinions and please be assured that your views are valued and that there are no right or wrong answers to the questions asked.

We will not collect any names, but only few demographic questions listed in next page as part of the discussion. Your identity will not be revealed to anyone other than the researchers conducting this survey. *[Alternatively use keyed anonymity where contact details are held separately which can link the participants input to their contribution provided the researcher has access to both sets of data, for example: I will store your name and email address so that I can contact you in 6 months' time to ask follow up questions. This spreadsheet and contact details will be password protected and the password known only to me and my supervisors, and will not be shared with any third parties. The spreadsheet will be kept on my password protected desktop and will be destroyed at the end of my degree in September 2018. Your name and email address will not be published as part of my research. As all data is presented in aggregate format it will not be possible to identify any individuals from their responses].*

Participation is entirely voluntary and you are free to withdraw from the interview at any time you feel uncomfortable or unwilling to participate, and you do not have to specify a reason. The discussion will be audio or video recorded if you agree, and the anonymised transcripts of the audio/video recordings will be used by the researchers working on the project. Once transcribed the original recording will be deleted. Your anonymity will not be compromised as only the reference number above will be used to identify the transcript. If at any stage you wish to receive further information about this research project, please to not hesitate to contact Nur Hafizah Muhammad (me) before July 2018. The findings will be written up into my thesis/included in a report to sponsor/ published in academic journals. This will not affect your anonymity.

All data I collect will be stored securely electronically on a password-protected computer or in hard copy version in a locked cupboard following the University of Reading guidelines. The data will be destroyed at the end of the research project no later than 31/12/18.

By participating in this interview, you are acknowledging that you understand the terms and conditions of participation in this study and that you consent to these terms.

This research project has been reviewed according to the procedures specified by the University Research Ethics Committee, and has been given a favourable ethical opinion for conduct.

Thank you very much for taking time to take part in this research!

[NUR HAFIZAH MUHAMMAD]

Student Contact Details

School of Agriculture, Policy and Development
Agriculture Building
Earley Gate, Whiteknights Road
PO Box 237
Reading RG6 6AR
United Kingdom
E-Mail: n.h.muhammad@pgr.reading.ac.uk

Supervisors Contact Details

Name: Dr Giuseppe Nocella
Phone: + 44 (0) 118 378 8904
E-Mail: g.nocella@reading.ac.uk

Name: Mr Nick Beard
Phone: + 44 (0) 118 378 8299
E-Mail: n.f.beard@reading.ac.uk

Consent Form

1. I have read and had explained to me by Nur Hafizah Muhammad and the accompanying Information Sheet relating to the project on:

Pro-environmental behaviours impact on consumer choices of sustainable food packaging.
2. I have had explained to me the purposes of the project and what will be required of me, and any questions I have had have been answered to my satisfaction. I agree to the arrangements described in the Information Sheet in so far as they relate to my participation.
3. I understand that participation is entirely voluntary and that I have the right to withdraw from the project any time, and that this will be without detriment.
4. I agree to the discussion session being video/audio taped.
5. This application has been reviewed by the University Research Ethics Committee and has been given a favourable ethical opinion for conduct.

6. I have received a copy of this Consent Form and the accompanying Information Sheet.

Name:

Signed:

Date:

Demographic profile

Gender:

- Male
- Female

Age:

- 19 – 29
- 30 – 39
- 40 – 49
- 50 – 59
- 60 – 69
- 70 +

Education level:

- Less than high school
- High school
- Tertiary other than university
- University degree
- Post-graduate degree

Occupation:

- Higher managerial, administrative or professional
- Intermediate managerial, administrative or professional
- Supervisory or clerical and junior managerial, administrative or professional
- Skilled manual worker
- Other: _____

Household income range per year:

- Up to £ 15,000 - £ 20,000
- £ 21,000 - £ 30,000
- £ 31,000 - £ 40,000
- £ 41,000 - £ 50,000
- £ 51,000 - £ 60,000
- £ 61,000 - £ 70,000
- More than £ 70,000

Active in environmental organisation:

- Yes
- No

Appendix 10 Example of focus group transcription

Focus Group 1: Transcriptions by parts

P1: What is sustainability to you? How important sustainability to yourself and your families?

Jamila

I think sustainability for me would be thinking about the environment and the future for the younger generations. And what we do now, how it will impact the future. So that's what I think about in terms of sustainability. I think plastic. I went to India last year, and when we were doing shopping, they gave us material bags that are recycled materials. And we used those cloth bags instead of having the plastic. I think it was the plastic wastage that created a lot of problems for them, more so in the smaller villages where there weren't waste management processes.

Louie

I mean there's a lot focus on energy within sustainability like different ways of generating different sources of energy. When I think of sustainability, I think a lot about solar power, wind power, and all that sort of stuff. There's a general definition for it, but there's so much which goes within that in different sections

Jack

Yes, it's just your actions today and how are they going to impact the future, and how what we can change the way we're looking at some stuff like technologies. We can make them more energy efficient, greener, and it will have significant positive impacts for the future in terms of---

Bethan

Pretty much what was previously being said. Yes, working on ways to make sure that things that we have now can be modified or altered or thought about differently to make sure that it can be better in the future for us. Plastic. There's loads of plastic in the ocean which is having a detrimental effect on wildlife in the ocean. Yes, plastic definitely.

Adam

It's quite important to me. It does fact affect the food that I eat. I'm actually vegan, so I require a conscious decision in the things that I eat in that way.

Ian

I mean I'm not a vegan, but I try and eat as healthy as possible. So I like to know kind of where my food comes from, how it's kind of been looked after or something, where it's been travelling from, that kind of thing.

Jade

Yes, I would agree, just like making different choices now to affect the future. Stop continuing to be so bad for the environment. Maybe like animal farming, like agriculture, like how much meat we consume as a society. It's not that sustainable for the environment because you have to cut down more trees and make way for the animals.

Appendix 11 Ethical clearance for questionnaire

School of Agriculture, Policy and Development

**ETHICAL CLEARANCE
GRANTED**



Form 2. MSc PhD Staff Ethical Clearance Submission Form

PLEASE allow a minimum of 3 weeks for this process.

You must not begin your research until you have obtained consent as evidenced by this form returned from the APD student Office signed and dated. Ethical Clearance cannot be granted retrospectively.

This form can only be used if the application :

- Does not involve participants who are patients or clients of the health or social services
- Does not involve participants whose capacity to give free and informed consent may be impaired within the meaning of the Mental Capacity Act 2005
- Does not involve patients who are 'vulnerable'
- Does not involve any element of risk to the researchers or participants
- Does not involve any participants who have a special relationship to the researchers/investigators

If any of the above apply, please refer to the APD Ethics Chair to decide whether an application can be made through the APD review process or whether the application needs to be referred to the full University Committee.

It is the applicant's responsibility to check for any particular requirements of a funder regarding ethical review. Some funders may require that the application is reviewed by full University Committee and not the devolved School committee.

Full details of the University Research Ethics procedures are available at <http://www.reading.ac.uk/internal/res/ResearchEthics/reas-REethichomepage.aspx> and you are encouraged to access these pages for a fuller understanding. Some helpful advice is available on this link <http://www.reading.ac.uk/internal/res/ResearchEthics/reas-REwhatdoIneedtodo.aspx> and the FAQs are particularly relevant.

ALL QUESTIONS MUST BE COMPLETED.

APD Ethical Clearance Application Reference Number : [Click here to enter text.](#)

1. APPLICANT DETAILS:

Main applicant name:	Nur Hafizah Muhammad
Name of academic supervisor/project investigator:	Dr Giuseppe Nocella and Mr Nick Beard
Email Address (decision will be emailed here):	n.h.muhammad@pgr.reading.ac.uk
MSc Student	<input type="checkbox"/>
PhD Student	<input checked="" type="checkbox"/>
Staff Member	<input type="checkbox"/>
Other (please specify)	Click here to enter text.

2. PROJECT DETAILS:

Title of project: Pro-environmental behaviours impact on consumer choice of innovation sustainable food packaging
Please provide a lay summary of the project, including what is being investigated and why: This study aims to explore

Appendix 12 Questionnaire of choice experiment Block 1 and 2

Consent letter

Dear Sir or Madam,

You are invited to participate in this web-survey on innovative sustainable food packaging. This research project is conducted by Nur Hafizah Muhammad, a PhD candidate at the School of Agriculture, Policy and Development of the University of Reading. Your participation in this survey is voluntary and you will not receive any direct benefits from participating in this research. However, your responses may help us to learn more about consumers' acceptance and preferences of innovative sustainable packaging in the UK which is an important aspect to help us understand and to better manage disposal of solid waste in the environment.

The survey has been approved by the ethical committee of the School of Agriculture, Policy and Development of the University of Reading. There are no foreseeable risks involved in participating in this study other than those encountered in day-to-day life. Moreover, some survey questions may cause emotional discomfort, sensitivity or may be distressing to you as you may think about your past experiences. However, all possible risks or discomforts of this study are minimal. You may feel a bit tired answering the long survey questions. As for confidentiality, your survey answers will be stored in a password protected electronic format. Moreover, QUALTRICS has been set up to avoid collecting any identifying information and your responses will remain anonymous.

Contact information:

If you have questions at any time about the study, you may contact me or my research supervisors' email as followed:

Me: Nur Hafizah Muhammad
n.h.muhammad@pgr.reading.ac.uk

Supervisors: Dr Giuseppe Nocella
g.nocella@reading.ac.uk

Mr Nick Beard
n.f.beard@reading.ac.uk

Electronic consent: Please select your choice below. Clicking the 'Agree' button indicates that:

1. You have read the above information
2. You have volunteered to participate

- Disagree
- Agree

Why have you received this survey?

We are conducting a survey to find out about your viewpoint and preferences on innovative sustainable packaging for food products. Your response will help us to gather more information about a type of packaging which is more environmentally friendly. Please help us to completing this survey which takes on average about 20 minutes. This survey has been specifically given to you because your opinion as consumers matters and we would like to underline that there are not right or wrong answers but what counts is only your frank opinion.

Finally, we would like to stress that data collected from this survey will be treated in the strictest confidence and anonymity is guaranteed. This study has been approved by the Ethical Committee from School of Agriculture, Policy and Development, University of Reading.

Before you continue with this survey, please can you tell us?

- 1. Are you responsible for your food shopping?
 - Yes
 - No (*end of survey)

- 2. Do you consume dairy milk?
 - Yes
 - No *if no, end of the survey

Section 1

Please indicate how important the following statements are for you. Each statement is measured on a 9-point scale where:

- 1 = Opposed to my principles
- 0 = Not important at all
- 1 = Not important
- 2 = Not really important
- 3 = Slightly important
- 4 = Quite important
- 5 = Important
- 6 = Very important
- 7 = Extremely important

Items	-1	0	1	2	3	4	5	6	7
E1 Social power: control over others, dominance									
E2 Wealth: material possessions, money									
E3 Authority: the right to lead or command									
E4 Influential: having an impact on people and events									
A5 Equality: equal opportunity for all									
A6 A world at peace: free of war and conflict									
A7 Social justice: correcting injustice, care for the weak									
A8 Helpful: working for the welfare of others									
B9 Preventing pollution: protecting natural resources									
B10 Respecting the earth: harmony with other species									
B11 Unity with nature: fitting into nature									
B12 Protecting the environment: preserving nature									

Section 2

Please indicate your level of agreement or disagreement for the following statements. Each statement is measured on a 5-point scale ranging from:

5-point scale: 1 = Strongly disagree
 2 = Disagree
 3 = Neither disagree or agree
 4 = Agree
 5 = Strongly agree

Items	1	2	3	4	5
N1 We are approaching the limit of the number of people the earth can support.					
N2 Humans have the right to modify the natural environment to suit their needs.					
N3 When humans interfere with nature it often produces disastrous consequences.					
N4 Human ingenuity will ensure that we do not make the earth unlivable.					
N5 Humans are seriously abusing the environment.					
N6 The earth has plenty of natural resources if we just learn how to develop them.					
N7 Plants and animals have as much right as humans to exist.					
N8 The balance of nature is strong enough to cope with the impacts of modern industrial nations.					
N9 Despite our special abilities, humans are still subject to the law of nature.					
N10 The so-called 'ecological crisis' facing humankind has been greatly exaggerated.					
N11 The earth is like a spaceship with very limited room and resources.					
N12 Humans were meant to rule over the rest of nature.					
N13 The balance of nature is very delicate and easily upset.					
N14 Humans will eventually learn enough about how nature works to be able to control it.					
N15 If things continue on their present course, we will soon experience a major ecological catastrophe.					

Section 3

Please read carefully the following information:

The excessive use of landfill to dispose of food packaging waste and its accumulation in the environment has triggered sustainability campaigns which aim at increasing consumers' awareness of this contemporary issue. As a result, the UK food and drink industry is paying attention to new packaging that should be used to market food products to consumers. Therefore, the development of packaging called 'sustainable packaging' is attracting attention from the food and drink industry as well as the UK Government, which is supporting innovative packaging with regulations aimed at protecting consumers and the environment in the long run.

Before you continue to answer this survey, we would like to know whether you are familiar with the following definitions of packaging: food packaging, food packaging waste and sustainable packaging.

- **“Food packaging”** is any material used to hold, protect, handle, deliver and present food and drink items. This includes packaging for raw materials right through to finished food items ready for sale or actually being sold. Are you familiar with this definition?

- Yes
- No

- **“Food packaging waste”** is any packaging or packaging material that has been used to cover food or drink items that, once served its intended purpose the holder disposes of or is required to dispose of. Are you familiar with this definition?

- Yes
- No



- **“Sustainable packaging”** is used to describe packaging that satisfies the needs of present generations without risking the needs of future generations. Sustainable packaging:

- is beneficial and safe for individuals and communities throughout its life cycle;
- meets market criteria for both performance and cost;
- is sourced, manufactured, transported, and recycled using renewable energy;
- optimizes the use of renewable or recycled source materials;
- is manufactured using clean production technologies and best practices;
- is made from materials healthy throughout the life cycle;
- is physically designed to optimize materials and energy;
- is effectively recovered and utilized in biological or industrial closed loop cycles.

Are you familiar with this definition?

- Yes
- No

Please indicate your level of agreement or disagreement with the following statements regarding consequences of food packaging waste. Each statement is measured on a 5-point scale ranging from:

- 1 = Strongly disagree
- 2 = Disagree
- 3 = Neither disagree or agree
- 4 = Agree
- 5 = Strongly agree

Items	1	2	3	4	5
AC1 Food packaging waste contributes to biodiversity loss.					
AC2 Food packaging waste continues to increase pollution to the environment.					
AC3 Food packaging waste leads to a decrease in the individual's well-being by contaminating the environment with hazardous waste.					
AC4 *Without food packaging waste, it is difficult to maintain the safety and quality of food products.					
AC5 Food packaging waste causes the depletion of non-renewable natural resources such as fossil fuels.					
AC6 Food packaging waste will damage this planet further.					
AC7 *Food packaging waste is necessary because without it people working in the packaging industry will lose their jobs.					
AC8 Food packaging waste incurs high disposal costs because it must be handled and processed on site.					
AC9 *Reducing food packaging waste will cause a loss of monetary benefits for people involved in managing and selling it.					

Please indicate your level of agreement or disagreement with the following statements regarding responsibility of food packaging waste. Each statement is measured on a 5-point scale ranging from:

- 1 = Strongly disagree
- 2 = Disagree
- 3 = Neither disagree or agree
- 4 = Agree
- 5 = Strongly agree

Items	1	2	3	4	5
AR1 I feel personally responsible for the environmental problems resulting from my disposal of food packaging in a manner that is not eco-sensitive.					
AR2 I feel personally responsible for the increase of food packaging waste when I am careless about discarding my food packaging in the correct bins available.					
AR3 When I go shopping, I only buy food items that I consume because I do not waste food and unnecessary food packaging.					
AR4 When I go shopping for my food items, I always choose packaging which is environmentally friendly.					
AR5 *In principle, single individuals like myself cannot contribute to the decrease in food packaging waste.					
AR6 Usually, I seriously consider what I buy before purchasing to avoid the risk of pollution caused by the disposal of my food packaging.					
AR7 I follow the instructions/leaflets on how to discard food packaging waste at home given by authorities at all times.					
AR8 I take care to consume food products before they spoil to avoid the unnecessary increase of food packaging waste from my home.					
AR9 When I go shopping for my food items, I never buy the 5 pence plastic bags.					

Please indicate your level of agreement or disagreement with the following statements regarding your behaviour in relation to food packaging waste. Each statement is measured on a 5-point scale ranging from:

- 1 = Strongly disagree
- 2 = Disagree
- 3 = Neither disagree or agree
- 4 = Agree
- 5 = Strongly agree

Items	1	2	3	4	5
PN1 I should plan my meals for several days in advance to dispose of food packaging more efficiently in the future.					
PN2 I personally feel that it is important to think about the environment when I make decisions to buy food products.					
PN3 I would be a better person if I consumed sustainable food packaging which is environmentally friendly.					
PN4 I feel a moral obligation to dispose of all my food packaging correctly in appropriate bins.					
PN5 I feel guilty when I do not protect quality of the environment by using non-sustainable food packaging.					
PN6 I have a very bad conscience when I dispose of expired food because I also generate more packaging waste.					
PN7 If I were to change my shopping behaviour today, I would feel a moral obligation to replace my current choices with food products that used sustainable packaging even if they cost more.					
PN8 Personally, I feel that it is important to choose food products that require as little packaging material as possible.					
PN9 I would consider myself a better person if I make the best use of food packaging waste at home by re-using it, for example.					

Section 4

Because **FRESH DAIRY MILK** is highly consumed in the UK, the food and drink industry is focused on this product to produce and introduce 'new sustainable packaging'. As a result, we would like to know something about your shopping habits in relation to food and fresh milk in particular.

1. What is your weekly expenditure for food?

£ _____

2. How many litres of fresh milk does **your family** consume per week?

- 1 pint (568 mL)
- 1 to 1 ½ pint (852 mL)
- 2 pints (1.1 L)
- 2 to 2 ½ pints (1.4 L)
- 3 pints (1.7 L)
- 3 to 3 ½ pints (2 L)
- More than 3 to 3 ½ pints (2 L). Please specify: _____

3. What type of fresh milk do you consume?

- Whole milk
- Semi-skimmed milk
- Skimmed milk

- 1% fat milk

4. What kind of fresh milk do you consume?

- Conventional
- Organic
- Lactose-free
- Respecting animal welfare
- Other (Please specify) _____

5. Where do you usually buy fresh milk?

- Large supermarket
- Supermarket chain local shops
- Small grocery stores or corner shops
- Street markets
- Farmers markets
- Farm shops
- Other (Please specify): _____

6. How often do you shop for your fresh milk?

- Every day
- Every 2-3 days
- Once a week
- Every two weeks
- Once a month

7. Which type of packaging material do you prefer when buying fresh milk?



Glass



Plastic



Tetra Pak

8. How do you normally dispose of your milk packaging?

- Regular bin
- Recycle bin
- Burn it
- Home composting
- In garden / field
- Other: Please specify: _____

Section 5

Bioplastic is a new packaging material which could reduce the consumption of crude oil plastic for food and drink products. Bioplastics are made from sustainable plant sources that challenge from crude oil-based packaging products. For example, bioplastic packaging could be made from biological sources such as starch or the cellulose from trees and straw.

Now we would like you to read the information about Bioplastic packaging and its characteristics carefully because the rest of this survey will use these terms.

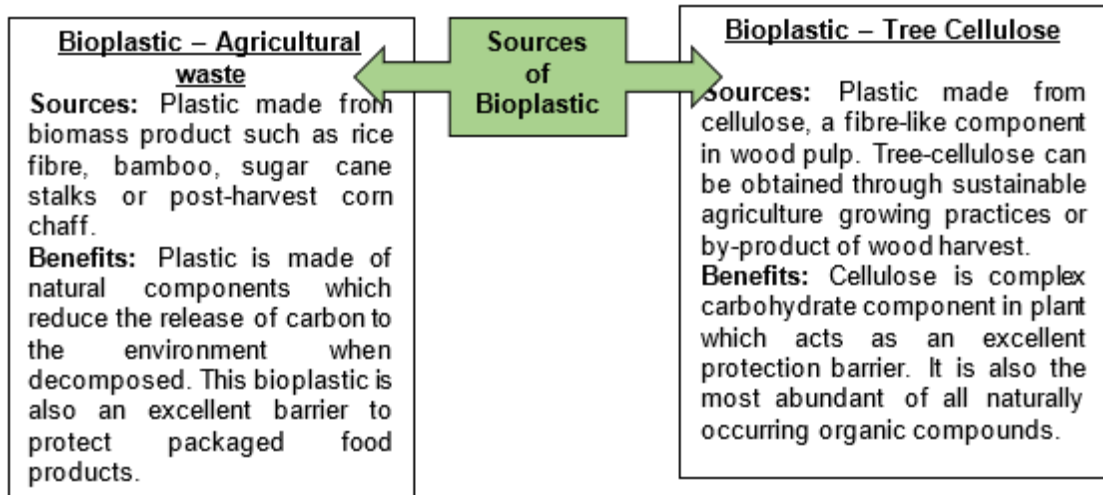

1. Did you know that bioplastic can be obtained from agricultural waste?
 - Yes
 - No
2. Did you know that bioplastic can be obtained from tree cellulose?
 - Yes
 - No

Please read carefully the disposal options for bioplastic:

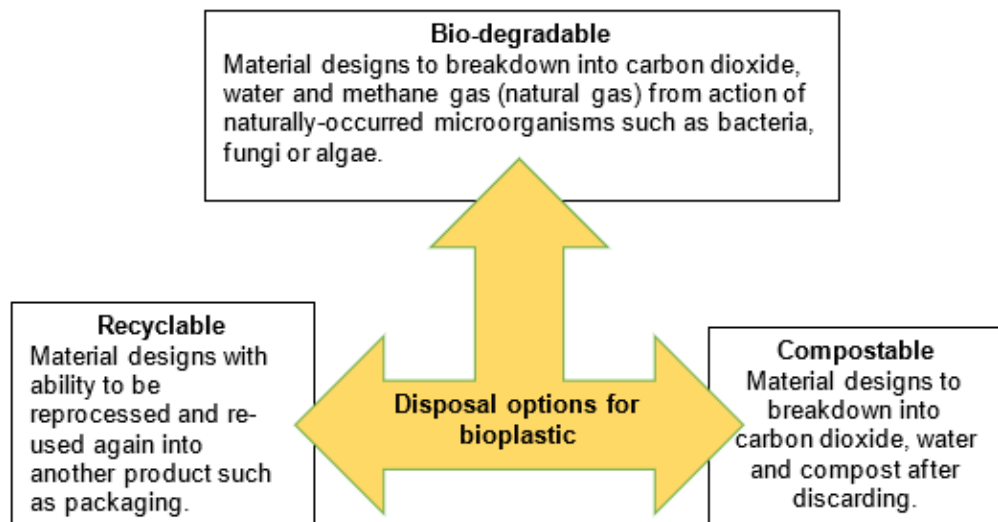

1. Did you know anything about recyclable material?
 - Yes
 - No

2. Did you know anything about bio-degradable material?
 - Yes
 - No

3. Did you know anything about compostable material?
 - Yes
 - No

4. Did you know anything about the certified source of bioplastic?
 - Yes
 - No

Section 6

Now imagine that you are standing in front of the supermarket shelf where next to the fresh milk that “you usually buy” there is also fresh milk packaged with bioplastic. Because bioplastic can have different characteristics, we would like you to evaluate different types of bioplastic packaging with respect to the following characteristics: *sources of bio-plastic*, *disposal options*, *certification* and *price*. If you **are not happy about information regarding these characteristics**, please go back to the previous page and carefully read the given information again.

Below you can see an example of a typical choice card that will show you the tasks that you have to undertake to evaluate this innovative bioplastic packaging. Each choice card consists of three options: “Milk A”, “Milk B” and “My usual milk packaging”. Milk A and Milk B show different combinations of the above mentioned characteristics that bioplastic milk packaging might have, but in terms of food quality this milk is the same as the milk that you usually buy. The third option refers to the milk that you usually buy in terms of quality and packaging.

Example:

Which option of milk packaging do you prefer?

	MILK A	
	Bioplastic	Tree cellulose
	Disposal type	Biodegradable
	Bioplastic certified label on package	No
	Price	80% more than I usual pay



	MILK B	
	Bioplastic	Agricultural waste
	Disposal type	Compostable
	Bioplastic certified label on package	Yes
	Price	40% more than I usual pay

	MY USUAL MILK PACKAGING	



Now we would like you to pay attention to the following six choice tasks which illustrate different choice situations of innovative bioplastic packaging that you might evaluate when shopping for fresh milk. We would like you to consider each of the six choice situations separately from the others, as if you were making shopping choices on different days. Please make your six choices but before answering. Remember that your budget is limited and so spending more for this innovative milk packaging you will have less money to buy other goods and services.

Block 1



Card 1: Which option of milk packaging do you prefer?

	MILK A			MILK B		
	Bioplastic	Tree cellulose		Bioplastic	Agricultural waste	
	Disposal type	Biodegradable		Disposal type	Compostable	
	Bioplastic certified label on package	No		Bioplastic certified label on package	Yes	
Price	80% more than I usual pay	Price	40% more than I usual pay	MY USUAL MILK PACKAGING		



Card 2: Which option of milk packaging do you prefer?

	MILK A			MILK B		
	Bioplastic	Agricultural waste		Bioplastic	Tree cellulose	
	Disposal type	Compostable		Disposal type	Recyclable	
	Bioplastic certified label on package	Yes		Bioplastic certified label on package	No	
Price	40% more than I usual pay	Price	80% more than I usual pay	MY USUAL MILK PACKAGING		



Card 3: Which option of milk packaging do you prefer?

	MILK A			MILK B		
	Bioplastic	Tree cellulose		Bioplastic	Agricultural waste	
	Disposal type	Recyclable		Disposal type	Biodegradable	
	Bioplastic certified label on package	Yes		Bioplastic certified label on package	No	
Price	20% more than I usual pay	Price	10% more than I usual pay	MY USUAL MILK PACKAGING		



Card 4: Which option of milk packaging do you prefer?

	MILK A			MILK B		
	Bioplastic	Agricultural waste		Bioplastic	Tree cellulose	
	Disposal type	Recyclable		Disposal type	Biodegradable	
	Bioplastic certified label on package	No		Bioplastic certified label on package	Yes	
Price	5% more than I usual pay	Price	20% more than I usual pay	MY USUAL MILK PACKAGING		

Card 5: Which option of milk packaging do you prefer?



	MILK A			MILK B		
	Bioplastic	Tree cellulose		Bioplastic	Agricultural waste	
	Disposal type	Compostable		Disposal type	Recyclable	
	Bioplastic certified label on package	No		Bioplastic certified label on package	Yes	
Price	10% more than I usual pay	Price	5% more than I usual pay	MY USUAL MILK PACKAGING		

Card 6: Which option of milk packaging do you prefer?



	MILK A			MILK B		
	Bioplastic	Agricultural waste		Bioplastic	Tree cellulose	
	Disposal type	Biodegradable		Disposal type	Compostable	
	Bioplastic certified label on package	Yes		Bioplastic certified label on package	No	
Price	5% more than I usual pay	Price	10% more than I usual pay	MY USUAL MILK PACKAGING		

Block 2



Card 1: Which option of milk packaging do you prefer?

	MILK A			MILK B		
	Bioplastic	Agricultural waste		Bioplastic	Tree cellulose	
	Disposal type	Recyclable		Disposal type	Biodegradable	
	Bioplastic certified label on package	Yes		Bioplastic certified label on package	No	
Price	10% more than I usual pay	Price	20% more than I usual pay	MY USUAL MILK PACKAGING		



Card 2: Which option of milk packaging do you prefer?

	MILK A			MILK B		
	Bioplastic	Agricultural waste		Bioplastic	Tree cellulose	
	Disposal type	Compostable		Disposal type	Biodegradable	
	Bioplastic certified label on package	No		Bioplastic certified label on package	Yes	
Price	40% more than I usual pay	Price	80% more than I usual pay	MY USUAL MILK PACKAGING		



Card 3: Which option of milk packaging do you prefer?

	MILK A			MILK B		
	Bioplastic	Tree cellulose		Bioplastic	Agricultural waste	
	Disposal type	Compostable		Disposal type	Recyclable	
	Bioplastic certified label on package	Yes		Bioplastic certified label on package	No	
Price	20% more than I usual pay	Price	5% more than I usual pay	MY USUAL MILK PACKAGING		



Card 4: Which option of milk packaging do you prefer?

	MILK A			MILK B		
	Bioplastic	Tree cellulose		Bioplastic	Agricultural waste	
	Disposal type	Biodegradable		Disposal type	Compostable	
	Bioplastic certified label on package	Yes		Bioplastic certified label on package	No	
Price	10% more than I usual pay	Price	10% more than I usual pay	MY USUAL MILK PACKAGING		

Card 5: Which option of milk packaging do you prefer?

	MILK A			MILK B		
	Bioplastic	Tree cellulose		Bioplastic	Agricultural waste	
	Disposal type	Recyclable		Disposal type	Compostable	
	Bioplastic certified label on package	No		Bioplastic certified label on package	Yes	
Price	80% more than I usual pay	Price	5% more than I usual pay	MY USUAL MILK PACKAGING		

Card 6: Which option of milk packaging do you prefer?

	MILK A			MILK B		
	Bioplastic	Agricultural waste		Bioplastic	Tree cellulose	
	Disposal type	Biodegradable		Disposal type	Recyclable	
	Bioplastic certified label on package	No		Bioplastic certified label on package	Yes	
Price	5% more than I usual pay	Price	40% more than I usual pay	MY USUAL MILK PACKAGING		

Section 7

The following questions explore your level of attention to characteristics of these new packaging alternatives that you evaluated when answering the six choice tasks. Before answering these questions please remember that all milk products that you evaluated were equal in terms of quality. The only differences between these products that you evaluated were related to the characteristics of bio-plastic packaging.

1. When choosing a 1-Litre bottle of fresh milk in bioplastic packaging, which of the following statements best represents your purchasing decision?
 - I only purchase bioplastic made from tree cellulose
 - I only purchase bioplastic made from agricultural waste
 - I do not care

2. Which of the following statements best describes your attitude in choosing the packaging for fresh milk?
 - I only choose recyclable milk packaging
 - I only choose bio-degradable milk packaging
 - I only choose milk packaged with compostable material
 - I do not care

3. Which of the following statements best describes your attitude in choosing packaging for fresh milk?
 - I need to see the official certification label of the source of bioplastic on milk packaging
 - I do not care

4. When you purchase a 1-Litre bottle of fresh milk in bioplastic packaging, is there always a maximum price you will pay?
 - No
 - Yes

If yes, which of the following price scales represents the maximum price you will pay?

- Extra 5% or less
- Extra 10%
- Extra 20%
- Extra 40%
- Extra 80% or more

Section 8

Despite the fact that bioplastic food packaging obtained from agricultural waste is one of the best sustainable alternatives to protect the environment using renewable resources, the new processing techniques that have to be fine-tuned and put in place to produce, this sustainable bio-plastic packaging might increase the final price of food products. Because of this, we would like you to imagine that you are shopping at your favourite retailer and most of the food products that you buy are marketed with bioplastic packaging obtained from agricultural waste. **Would you be willing to buy your food products marketed with bioplastic obtained from agricultural waste?**

- No
- Yes

If No. Why?

- I need more information about bioplastic to answer the question.
- I do not want to pay more for bioplastic packaging.
- I am already paying enough for other sustainable products.
- I cannot afford to pay more for bioplastic obtained from agricultural waste.
- Bio-plastic packaging obtained from agricultural waste should be used to market all food products at no-extra-costs.
- Other reason: Please specify: _____

If yes,

Now we would like you to think carefully about your weekly expenditure for food and the possibility of buying your food items with bio-plastic obtained only from agricultural waste. Because this change is likely to increase your food weekly expenditure we would like to know the maximum amount in **terms of percentage (%)** that you would be willing to pay to contribute to the reduction of agricultural waste and a better environment by buying food products packaged with this innovative type of **bioplastic**. Below there is a list of percentage increases which will affect your weekly expenditure for food £_____ that you stated previously. Please look at this list of percentages and indicate the **MAXIMUM** amount that you are willing to pay.

Before indicating the **MAXIMUM** increase that you are willing to pay please bear in mind that spending more for this sustainable packaging will not affect the quality of your food (i.e. food remains the same as before) and that you will have less available income for other goods and services.

Please indicate the **MAXIMUM** increase that you are willing to pay:

Amount you are willing to pay?	
1%	
2%	
4%	
8%	
10%	
15%	
20%	
25%	
30%	
40%	
50%	
More than 50% Please specify	

Section 9

A few questions about you

These final questions will help us to understand more about the responses you gave earlier in the survey. The information provided will not be passed to third parties and will be used only for academic purposes.

1. Please tell us how old are you?

- 16 – 24
- 25 – 34
- 35 – 44
- 45 – 54
- 55 – 64
- 65 – 74
- 75 and older

2. Are you?

- Male
- Female

3. What is your highest level of educational attainment achieved to date?

- Less than high school
- High school
- A-level
- Undergraduate degree
- Post-graduate degree
- Doctoral

4. What is your income per annum, before tax?

- Less than £10,000
- £10,001 - £20,000
- £20,001 - £30,000
- £30,001 - £40,000
- £40,001 - £50,000
- £50,001 - £60,000
- More than £60,000

5. Working status?

- Manager, director or senior official
- Professional occupation
- Associated professional or technical occupation
- Administrative or secretarial occupation
- Skilled occupation
- Caring, leisure or other service occupation
- Sales or customer service occupation
- Process, plant & machine operator
- Retired
- Still at school
- In full time higher education
- Unemployed (seeking work)
- Not in paid employment (not seeking work)

6. Apart from yourself, how many other household members share your groceries?

- None
- 2 persons
- 3 persons
- 4 persons
- 5 persons
- 6 persons
- 7 persons
- More than 8 persons

7. Presence of children in your household?

- None
- Any aged 0 – 4
- Any aged 5 – 9
- Any aged 10 – 12
- Any aged 13 – 15
- Any aged 16 – 18

END OF SURVEY

THANK YOU

Appendix 13 QUATRICS agreement

Qualtrics Research Services SOW

This Qualtrics Statement of Work ("SOW"), effective 18-Jul-2018 ("Effective Date"), is between Qualtrics, LLC ("Qualtrics") and University of Reading ("Subscriber") for purposes of a custom project ("Project") whose scope is specified below. Qualtrics and Subscriber are sometimes referred to herein individually as a "Party," and collectively the "Parties." In the framework of this SOW, Qualtrics will perform the work and develop, deliver, and assure the quality of the Project, specified below, as applicable, in accordance with the terms of this SOW. This SOW may be updated from time to time by Amendments executed by both Qualtrics and Subscriber. Subscriber agrees that Qualtrics may use partners for certain portions of the Services.

Qualtrics has developed a series of proprietary computer software programs that facilitate and automate the process of conducting surveys, polls, intercepts, and reports (the "Software"). Qualtrics provides its clients access to the Software as end users via an application service provider (ASP) model, in which Qualtrics uses, operates, and makes available the applicable software, network, systems, and other technologies in order to provide the Project.

For all purposes of this SOW, the term "Services" shall mean and refer to the specific version(s) of the Qualtrics survey, poll, reviews, intercept, and reporting service(s) specified herein and accessible at www.qualtrics.com.

Qualtrics and Subscriber agree that this Statement of Work and the Project provided hereunder are subject to the Terms of Service at <https://www.qualtrics.com/terms-of-service/> and the Privacy Statement at <https://www.qualtrics.com/privacy-statement/>, except as otherwise provided herein.



Data Ownership: Subscriber owns all right, title and interest in and to any responses, reports, personally identifiable information, and/or other information input or generated by or on behalf of Subscriber in connection with the Services (the "Data"). Notwithstanding the foregoing, for all purposes of this SOW, the Data shall be deemed to be Subscriber's Confidential Information and will not be utilized by Qualtrics for any purpose other than performing its obligations under this SOW or as may otherwise be agreed to in writing by the Parties. Notwithstanding anything to the contrary in this SOW, Subscriber agrees that Qualtrics may share Data with partners outside of the specified data center region to perform certain portions of the Project under this SOW.

Limitation of Liability. EXCEPT AS EXPRESSLY PROVIDED HEREIN, IN NO EVENT SHALL EITHER PARTY BE LIABLE TO THE OTHER OR TO ANY THIRD PARTY FOR ANY INDIRECT, PUNITIVE, SPECIAL, EXEMPLARY, INCIDENTAL, CONSEQUENTIAL, OR OTHER CONSEQUENTIAL DAMAGES OF ANY TYPE OR KIND (INCLUDING LOSS OF DATA, REVENUE, PROFITS, USE, OR OTHER ECONOMIC ADVANTAGE) ARISING OUT OF, OR IN ANY WAY CONNECTED WITH THE PROJECT, SOFTWARE, SERVICES, OR THIS SOW, INCLUDING, WITHOUT LIMITATION, THE USE OR INABILITY TO USE THE SERVICES, OR FOR ANY CONTENT OBTAINED FROM OR THROUGH THE SERVICES, ANY INTERRUPTION, INACCURACY, ERRORS, OR OMISSIONS, EVEN IF A PARTY HAS BEEN SPECIFICALLY ADVISED OF THE POSSIBILITY OF SUCH DAMAGES. IN NO EVENT SHALL EITHER PARTY'S TOTAL AGGREGATE LIABILITY HEREUNDER EXCEED THE AMOUNTS ACTUALLY PAID BY SUBSCRIBER TO QUALTRICS IN THE COURSE OF COMPLETION OF THE PROJECT.

Termination for cause. This SOW shall automatically terminate without any further obligation and without liability of either party upon the occurrence of the following: (a) either party commits a material breach of this agreement which such Party fails to cure within thirty (30) days after receipt of written notice outlining such material breach from the other Party; or (b) either party becomes insolvent, acknowledges insolvency in any manner, ceases to do business, makes an assignment for the benefit of its creditors, or files a petition in bankruptcy.

Upon termination for cause the breaching party shall pay all reasonable and remaining undisputed fees (if any) resulting from the termination.

Ownership: This SOW is not a sale and does not convey to Subscriber any rights of ownership in or related to the Software, Services, or intellectual property rights of Qualtrics.

Qualtrics, LLC	Subscriber
By: 	By: 
Name: Mark Creer	Name: Giuseppe Nocella
Title: Managing Counsel	Title: Dr
Date: Jul 18, 2018	Date: Jul 18, 2018

Qualtrics Contact	Subscriber Contact
Name: Phil Lennon	Name: Giuseppe Nocella
Phone:	Phone: +44 (0) 118 378 8904
Email: phil@qualtrics.com	Email: g.nocella@reading.ac.uk

Appendix 14 Matrix coding results of focus group

Parent themes	1st theme			2nd theme			3rd theme		
Demographic	Protecting ecosystem	Energy saving	Healthy lifestyles	User-friendly	Opportunity to reduce waste	Excessive waste	Safe for environment	Lifestyles preference	Food quality priority
Gender									
Male	47	36	57	5	14	37	16	15	8
Female	50	41	42	1	5	29	23	20	16
Age									
< 25 years	26	23	32	3	7	30	13	16	7
25 to <45 years	38	23	23	1	3	20	13	9	6
45 to <65 years	22	25	28	2	8	14	11	6	7
> 65 years	11	6	16	0	1	3	2	4	2
Education									
High school / tertiary	40	37	42	2	8	19	20	16	10
Degree / postgraduate	57	40	57	4	11	47	19	19	14
Income per year									
Up to £20,000	29	22	31	0	5	27	8	7	6
£21,000 - £40,000	26	35	42	2	8	16	14	12	10
£41,000 - £60,000	19	15	20	4	4	23	16	13	6
> £61,000	17	5	6	0	1	1	1	3	2

Parent themes	4 th theme					5 th theme				
Demographic	Sustainable facilities	Senseless food packaging	Sustainable campaign	Reduce environmental exploitation	More sustainable packaging alternatives	Satisfaction as consumer	Food item is priority	Price sensitive	Loopholes of sustainable claims	Consumer education
Gender										
Male	3	9	17	20	21	6	8	8	1	7
Female	9	9	14	18	16	5	7	2	2	4
Age										
< 25 years	8	12	16	12	15	3	6	0	1	7
25 to <45 years	2	1	7	12	6	5	4	2	0	3
45 to <65 years	2	5	8	14	12	3	4	8	2	1
≥ 65 years	0	0	0	0	4	0	1	0	0	0
Education										
High school / tertiary	3	5	10	13	24	2	6	2	1	4
Degree / postgraduate	9	13	21	25	13	9	9	8	2	7
Income per year										
Up to £20,000	4	3	8	9	14	6	3	1	1	6
£21,000 - £40,000	3	3	11	9	12	1	4	7	2	1
£41,000 - £60,000	4	10	8	16	10	4	6	0	0	2
> £61,000	1	2	4	4	1	0	2	2	0	2

Appendix 15 *NGENE syntax for choice experiment before and after pilot study*

Pilot study:

```
Design
;alts = alt1*, alt2*, alt3
;rows = 12
;block = 2
;eff = (mnl,d)
;model:
U(alt1) = b01 + b2.dummy[0] * A[0,1] + b3.dummy[0|0] * B[0,1,2] +
b4.dummy[0] * C[0,1] + b5[-0.01] * D[0.05,0.1,0.2,0.4,0.8] /
U(alt2) = b02 + b2          * A          + b3          * B          + b4
* C          + b5 * D
$
```

Actual study:

```
Design
;alts = alt1*, alt2*, alt3
;rows = 12
;block = 2
;eff = (mnl,d)
;model:
U(alt1) = b01 + b2.dummy[1.24] * A[0,1] + b3.dummy[0.58|0.31] *
B[0,1,2] + b4.dummy[0.16] * C[0,1] + b5[-4.16] *
D[0.05,0.1,0.2,0.4,0.8] /
U(alt2) = b02 + b2          * A          + b3          * B
+ b4          * C          + b5          * D
$
```

Appendix 16 Initial regression weight estimation Measurement Model 1

			Estimate	S.E.	C.R.	P	Label
E4	<---	EGO	.827	.049	16.771	***	par_1
E3	<---	EGO	1.000				
E2	<---	EGO	.693	.048	14.470	***	par_2
A8	<---	ALT	.822	.041	19.945	***	par_3
A7	<---	ALT	1.000				
A6	<---	ALT	.882	.041	21.362	***	par_4
B12	<---	BIO	.958	.036	26.419	***	par_5
B11	<---	BIO	1.000				
B10	<---	BIO	.988	.036	27.431	***	par_6
E1	<---	EGO	.983	.059	16.687	***	par_7
A5	<---	ALT	.839	.044	19.213	***	par_8
B9	<---	BIO	.944	.038	25.117	***	par_9
N1	<---	NEP	.615	.067	9.173	***	par_10
N2	<---	NEP	-.698	.079	-8.793	***	par_11
N3	<---	NEP	.823	.054	15.332	***	par_12
N4	<---	NEP	-.367	.073	-5.010	***	par_13
N5	<---	NEP	1.000				
N6	<---	NEP	.002	.072	.029	.977	par_14
N7	<---	NEP	.856	.056	15.252	***	par_15
N8	<---	NEP	-.788	.080	-9.841	***	par_16
N9	<---	NEP	.747	.053	13.981	***	par_17
N10	<---	NEP	-.866	.084	-10.373	***	par_18
N11	<---	NEP	.688	.067	10.227	***	par_19
N12	<---	NEP	-.855	.084	-10.209	***	par_20
N13	<---	NEP	.898	.056	16.083	***	par_21
N14	<---	NEP	-.409	.077	-5.302	***	par_22
N15	<---	NEP	.936	.060	15.592	***	par_23
PN1	<---	PN	.823	.055	14.854	***	par_24
PN2	<---	PN	1.000				

Appendix 16 Initial regression weight estimation Measurement Model 1 (continued)

PN3	<---	PN	.968	.050	19.470	***	par_25
PN4	<---	PN	.790	.047	16.813	***	par_26
PN5	<---	PN	.977	.049	19.747	***	par_27
PN6	<---	PN	.852	.058	14.709	***	par_28
PN7	<---	PN	.978	.053	18.283	***	par_29
PN8	<---	PN	.903	.046	19.528	***	par_30
PN9	<---	PN	.917	.048	18.956	***	par_31
AC1	<---	AC	.861	.052	16.485	***	par_32
AC2	<---	AC	.903	.046	19.544	***	par_33
AC3	<---	AC	.942	.049	19.080	***	par_34
AC4R	<---	AC	.410	.076	5.412	***	par_35
AC5	<---	AC	.890	.053	16.865	***	par_36
AC6	<---	AC	1.000				
AC7R	<---	AC	.489	.077	6.312	***	par_37
AC8	<---	AC	.703	.053	13.375	***	par_38
AC9R	<---	AC	.078	.075	1.028	.304	par_39
AR1	<---	AR	.809	.066	12.340	***	par_40
AR2	<---	AR	.708	.070	10.162	***	par_41
AR3	<---	AR	.735	.064	11.508	***	par_42
AR4	<---	AR	1.000				
AR5R	<---	AR	-.007	.077	-.097	.923	par_43
AR6	<---	AR	1.067	.070	15.217	***	par_44
AR7	<---	AR	.813	.063	12.893	***	par_45
AR8	<---	AR	.703	.057	12.320	***	par_46
AR9	<---	AR	.613	.077	7.988	***	par_47

*** At 0.05 significant level

Appendix 17 Final regression weight estimation Measurement Model 21

			Estimate	S.E.	C.R.	P	Label
E3	<---	EGO	1.000				
E2	<---	EGO	.536	.096	5.575	***	par_1
A8	<---	ALT	.819	.041	19.738	***	par_2
A7	<---	ALT	1.000				
A6	<---	ALT	.886	.041	21.392	***	par_3
B12	<---	BIO	.989	.036	27.427	***	par_4
B10	<---	BIO	1.000				
A5	<---	ALT	.843	.044	19.254	***	par_5
B9	<---	BIO	.981	.037	26.385	***	par_6
N1	<---	NEP	.607	.063	9.591	***	par_7
N3	<---	NEP	.816	.049	16.533	***	par_8
N5	<---	NEP	1.000				
N7	<---	NEP	.816	.052	15.678	***	par_9
N9	<---	NEP	.762	.049	15.476	***	par_10
N13	<---	NEP	.887	.051	17.325	***	par_11
N15	<---	NEP	.899	.055	16.217	***	par_12
PN1	<---	PN	.837	.059	14.204	***	par_13
PN2	<---	PN	.973	.051	18.906	***	par_14
PN3	<---	PN	1.000				
PN5	<---	PN	.990	.054	18.190	***	par_15
PN6	<---	PN	.871	.061	14.163	***	par_16
PN9	<---	PN	.927	.053	17.520	***	par_17
AC1	<---	AC	.876	.053	16.569	***	par_18
AC2	<---	AC	.912	.047	19.441	***	par_19
AC3	<---	AC	.954	.050	19.027	***	par_20
AC5	<---	AC	.909	.053	17.023	***	par_21
AC6	<---	AC	1.000				
AC8	<---	AC	.730	.053	13.785	***	par_22
AR3	<---	AR	.925	.067	13.832	***	par_23
AR7	<---	AR	.916	.066	13.943	***	par_24
AR8	<---	AR	1.000				
AR9	<---	AR	.688	.080	8.543	***	par_25

*** At 0.05 significant level

Appendix 18 Final regression weight estimation Structural Model 2

	Estimate	S.E.	C.R.	P	Label
NEP <--- EGO	-.072	.020	-3.695	***	par_28
NEP <--- ALT	.064	.040	1.612	.107	par_29
NEP <--- BIO	.263	.039	6.705	***	par_30
AC <--- NEP	.815	.049	16.779	***	par_31
AR <--- AC	.728	.053	13.819	***	par_32
PN <--- AR	.778	.061	12.853	***	par_33
E3 <--- EGO	1.000				
E2 <--- EGO	.611	.103	5.905	***	par_1
A8 <--- ALT	.827	.042	19.829	***	par_2
A7 <--- ALT	1.000				
A6 <--- ALT	.884	.042	21.134	***	par_3
B12 <--- BIO	.989	.036	27.285	***	par_4
B10 <--- BIO	1.000				
A5 <--- ALT	.848	.044	19.258	***	par_5
B9 <--- BIO	.984	.037	26.342	***	par_6
N1 <--- NEP	.606	.064	9.485	***	par_7
N3 <--- NEP	.820	.050	16.401	***	par_8
N5 <--- NEP	1.000				
N7 <--- NEP	.824	.053	15.661	***	par_9
N9 <--- NEP	.775	.050	15.597	***	par_10
N13 <--- NEP	.890	.052	17.172	***	par_11
N15 <--- NEP	.898	.056	15.987	***	par_12
PN1 <--- PN	.892	.062	14.311	***	par_13
PN2 <--- PN	1.000				
PN3 <--- PN	1.019	.058	17.504	***	par_14
PN6 <--- PN	.879	.065	13.472	***	par_15
PN9 <--- PN	.985	.056	17.492	***	par_16
AC1 <--- AC	.874	.053	16.513	***	par_17
AC2 <--- AC	.911	.047	19.376	***	par_18
AC3 <--- AC	.951	.050	18.929	***	par_19
AC5 <--- AC	.902	.054	16.861	***	par_20
AC6 <--- AC	1.000				
AC8 <--- AC	.733	.053	13.830	***	par_21
AR3 <--- AR	.919	.070	13.158	***	par_22
AR7 <--- AR	.970	.069	14.090	***	par_23
AR8 <--- AR	1.000				
AR9 <--- AR	.719	.084	8.521	***	par_24
WTP <--- PN	1.484	.240	6.171	***	par_34

*** At 0.05 significant level

Appendix 19 Post Hoc test for two – way ANOVA for tree cellulose bioplastic

Tests of Between-Subjects Effects					
Dependent Variable: WTP of tree cellulose bioplastic					
Source	Type III Sum of Squares	df	Mean Square	F	Sig.
Corrected Model	1.28 ^a	8	0.16	3.14	0.002
Intercept	13.41	1	13.41	263.14	0.000
Age	0.60	2	0.30	5.89	0.003
Income	0.41	2	0.21	4.06	0.018
Age * Income	0.40	4	0.10	1.98	0.096
Error	28.33	556	0.05		
Total	48.66	565			
Corrected Total	29.61	564			

a. R Squared = .043 (Adjusted R Squared = .029)

Post Hoc Tests: Age

Multiple Comparisons						
Dependent Variable: WTP of tree cellulose bioplastic						
Bonferroni						
Age	Age	Mean Difference	Std. Error	Sig.	95% Confidence Interval	
					Lower Bound	Upper Bound
18 – 34	35 – 54	0.013	0.022	1.000	– 0.040	0.066
	55 and older	0.064*	0.025	0.029	0.004	0.124
35 – 54	18 – 34	– 0.013	0.022	1.000	– 0.066	0.040
	55 and older	0.051	0.023	0.095	– 0.006	0.109
55 and older	18 – 34	– 0.064*	0.025	0.029	– 0.124	– 0.005
	35 – 54	– 0.051	0.024	0.095	– 0.109	0.006

Based on observed means.

The error term is Mean Square (Error) = 0.051.

*. The mean difference is significant at the 0.05 level.

Post Hoc Tests: Income

Multiple Comparisons						
Dependent Variable: WTP of tree cellulose bioplastic						
Bonferroni						
Income	Income	Mean Difference	Std. Error	Sig.	95% Confidence Interval	
					Lower Bound	Upper Bound
Low income	Middle income	- 0.062*	0.021	0.009	- 0.113	- 0.012
	High income	- 0.065	0.027	0.053	- 0.131	0.0006
Middle income	Low income	0.063*	0.021	0.009	0.012	0.114
	High income	- 0.002	0.029	1.00	- 0.072	0.067
High income	Low income	0.065	0.027	0.053	- 0.0006	0.131
	Middle income	0.002	0.029	1.00	- 0.067	0.072

Based on observed means.

The error term is Mean Square (Error) = 0.051.

*The mean difference is significant at the 0.05 level.

Appendix 20 Differences between National Statistic and sample demographic profiles

Year	Demographic profile	Population	%	Sample	%	
2015	Gender	Male	22941259	48.9	225	39.8
		Female	23983751	51.1	340	60.2
2015	Age	18-34	7863016	35.9	188	33.3
		35-54	7467929	34.1	230	40.7
		55 and above	6565140	30.0	147	26.0
2017	*Occupation	Managerial and administrative	4396000	38.9	207	36.6
		Skilled and services	5449000	48.3	128	22.7
2018		Retired	19199	0.2	83	14.7
2018		Unemployed: students, etc.	1425000	12.6	147	26.0
2017	*Education	High school or less	7000000	33.3	354	62.7
		University degree and above	14000000	66.7	211	37.3

APPENDIX 21 Independent t-test between WTP (Model 2) attributes and dairy milk shopping habits

Tree cellulose (ref. Agricultural waste)

Type of milk

```
. ttest mxlnprice_biotree, by(Milkkind_new)
```

Two-sample t test with equal variances

Group	Obs	Mean	Std. Err.	Std. Dev.	[95% Conf. Interval]	
Others:	84	-.1247962	.0258521	.2369389	-.1762151	-.0733773
Conventi	481	-.193916	.0103233	.2264085	-.2142005	-.1736315
combined	565	-.1836398	.0096389	.2291151	-.2025724	-.1647072
diff		.0691198	.0269607		.016164	.1220756

```
diff = mean(Others:) - mean(Conventi)          t = 2.5637
Ho: diff = 0                                  degrees of freedom = 563
```

```
Ha: diff < 0                                Ha: diff != 0                                Ha: diff > 0
Pr(T < t) = 0.9947                          Pr(|T| > |t|) = 0.0106                          Pr(T > t) = 0.0053
```

Shop for milk

```
. ttest mxlnprice_biotree, by( Milkbuy_new )
```

Two-sample t test with equal variances

Group	Obs	Mean	Std. Err.	Std. Dev.	[95% Conf. Interval]	
Almost e	241	-.1583394	.0148355	.2303095	-.1875639	-.1291149
At least	324	-.2024589	.0125972	.2267502	-.2272419	-.1776759
combined	565	-.1836398	.0096389	.2291151	-.2025724	-.1647072
diff		.0441196	.0194178		.0059794	.0822597

```
diff = mean(Almost e) - mean(At least)          t = 2.2721
Ho: diff = 0                                  degrees of freedom = 563
```

```
Ha: diff < 0                                Ha: diff != 0                                Ha: diff > 0
Pr(T < t) = 0.9883                          Pr(|T| > |t|) = 0.0235                          Pr(T > t) = 0.0117
```

Recyclable (ref. compostable)

Disposal

```
. ttest mxlnprice_recycle, by(Dispose_new)
```

Two-sample t test with equal variances

Group	Obs	Mean	Std. Err.	Std. Dev.	[95% Conf. Interval]	
Others:	80	.0326944	.012446	.1113205	.0079212	.0574675
Recycle	485	.0626306	.005339	.1175796	.0521401	.0731211
combined	565	.0583918	.0049258	.1170849	.0487167	.068067
diff		-.0299362	.0140851		-.0576019	-.0022705

```
diff = mean(Others:) - mean(Recycle)          t = -2.1254  
Ho: diff = 0                                degrees of freedom = 563
```

```
Ha: diff < 0  
Pr(T < t) = 0.0170
```

```
Ha: diff != 0  
Pr(|T| > |t|) = 0.0340
```

```
Ha: diff > 0  
Pr(T > t) = 0.9830
```